

## Battery System

## SUBMITTAL DRAWING

JOB: _____	REPRESENTATIVE: _____
_____	_____
_____	_____
ENGINEER: _____	ORDER NO: _____ DATE: _____
CONTRACTOR: _____	SUBMITTED BY: _____ DATE: _____
_____	APPROVED BY: _____ DATE: _____

### 12 VOLT DUAL BATTERY SYSTEM LEAD - ACID TYPE

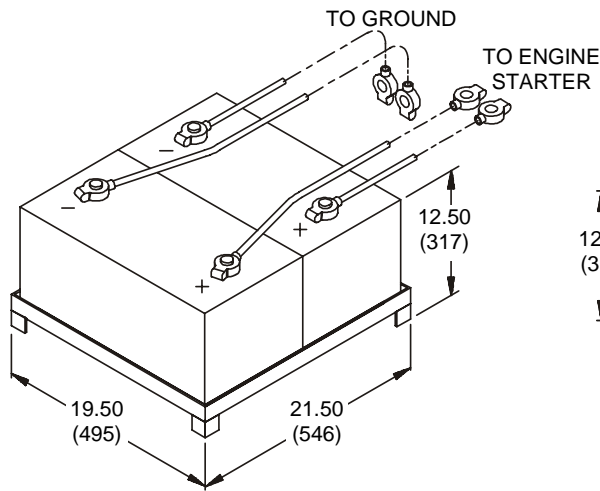

### 24 VOLT DUAL BATTERY SYSTEM LEAD - ACID TYPE

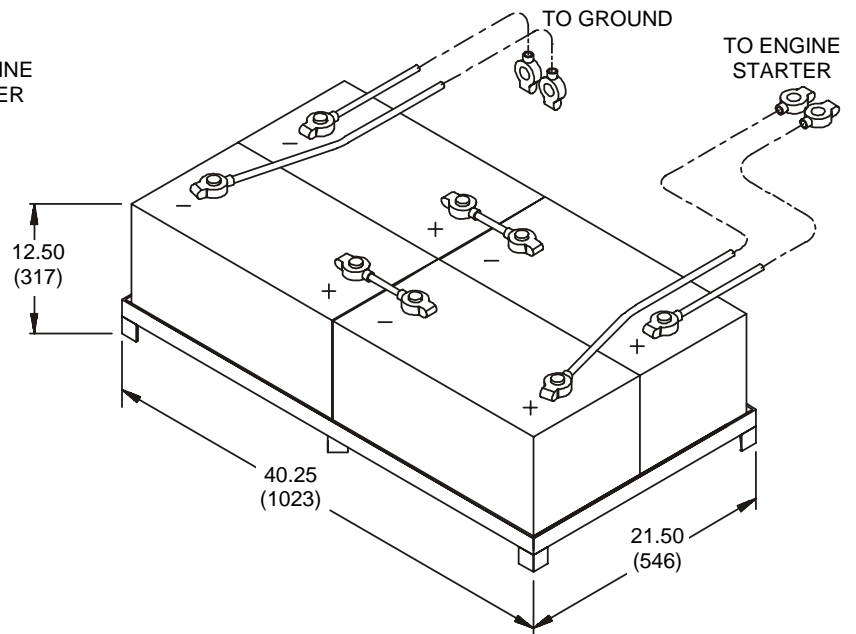

**Notes:**

- All Cables AWG # 2/0 x 5' - 0" long
- Shipping Weight  
 12 V System Dry: 140 lbs. (64 kg)  
 24 V System Dry: 270 lbs. (123 kg)
- Acid Shipped Separately  
 20 Litres / 2 batteries: 58 lbs. (26 kg) as per NFPA-20 Section 11.2.5.2.2
- Acid not supplied when shipped by ocean freight & air freight

DWG#	DATE:	REV:
All dimensions are in inches (mm)		

**Notes:** Dimensions are not used for construction purposes unless certified.  
Data subject to change without notice.

**Armstrong Pumps Inc.**  
 93 East Avenue  
 North Tonawanda, New York  
 U.S.A. 14120-6594  
 Tel: (716) 693-8813  
 Fax: (716) 693-8970  
[www.armstrongpumps.com](http://www.armstrongpumps.com)

**Armstrong Holden Brooke Pullen**  
 Wenlock Way  
 Manchester  
 United Kingdom, M12 5JL  
 Tel: +44 (0) 1612 232223  
 Fax: +44 (0) 1612 209660



**S.A. Armstrong Limited**  
 23 Bertrand Avenue  
 Toronto, Ontario  
 Canada, M1L 2P3  
 Tel: (416) 755-2291  
 Fax: (416) 759-9101

**Armstrong Darling**  
 9001 De L'Innovation, Suite 200  
 Montreal (Anjou), Quebec  
 Canada, H1J 2X9  
 Tel: (514) 352-2424  
 Fax: (514) 352-2425

