

ARMSTRONG



Pump-in-a-Box (PiB) 4380 IVS, 4360 & 4380 Series

FILE NO:	43.12
DATE:	Aug. 12, 2010
SUPERSEDES:	43.12
DATE:	May 27, 2010

Factory-Built Commercial Pumps In Stock



The PiB Series builds on the quality and unsurpassed performance you've come to expect from Armstrong commercial pumps. Pump-in-a-Box (PiB) models are packaged for warehouse distribution or shipment within hours of the order. Current PiB models include the 4380 IVS, 4360 and 4380 Series Vertical In-Line pumps, available with an extensive selection of impeller and motor combinations, to cover a wide range of head and flow requirements.



▶ Intelligent Variable Speed Pumps

Armstrong PiB 4380 IVS pumps are the next generation in variable speed pumping, offering the element of built-in intelligence in a motor mounted VFD. The IVS pump is pre-programmed with Sensorless control technology that senses the energy input to the pump and automatically adjusts the speed to the demand of a pre-set system control curve. The IVS controller provides the operating cost savings of a traditional variable speed system, without the added installation expense and complexity of a remote pressure sensor. It is the first true plug-and-play intelligent pump on the market, available only from Armstrong.

▶ Direct Replacement

PiB 4360 & 4380 pumps are available with standard NPT connections and ANSI 125 flanges, bronze impellers and standard JM/JP/56C motors with common electrical configurations. The wide array of connection sizes, impeller diameters and motors allow for a simple and direct replacement of almost any pump.

▶ IVS Retrofit

Existing constant speed pumps can seamlessly be upgraded to a PiB 4380 IVS, in systems with 2-way control valves. Simply install the PiB 4380 IVS into the pipeline with the same installation method used for constant speed pumps. Expensive modifications to your current piping system or building structure are no longer required to minimize operating costs. An integrated keypad makes it easy to adjust the pump head to match the system demand and instantly maximize your energy savings. No specialized technicians, remote system sensors or other complex electronic devices are required.

PiB 4360 & 4380 Series

► Efficiency

Mechanically sealed pumps provide far greater efficiency compared to canned rotor designs. This design feature reduces power consumption and energy costs.

► Versatility

For applications such as boiler recirculation, heat exchangers, chilled water recirculation or cooling tower pumps, the PiB offering has models and sizes to meet your need. PiB IVS models offer the benefits of variable-speed operation and can also serve constant-speed applications by running at a pre-selected speed.

► Quality

Armstrong VIL pumps have been installed in thousands of applications all over the world and have demonstrated high performance, consistent efficiency, and maximum durability. The Armstrong Type 2A mechanical seal has a Silicon Carbide stationary seal which makes it one of the most reliable seals on the market today.

► Ease Of Maintenance

Since the PiB Series is based on current proven Armstrong commercial pumps, replacement parts are readily available. All PiB Series pumps include industry-standard mechanical seals, ensuring quick and economical service. In the event of regular scheduled maintenance, downtime is minimized. All VIL units can be serviced without disturbing the pump casing.



► Performance Curves

PiB 4380 IVS

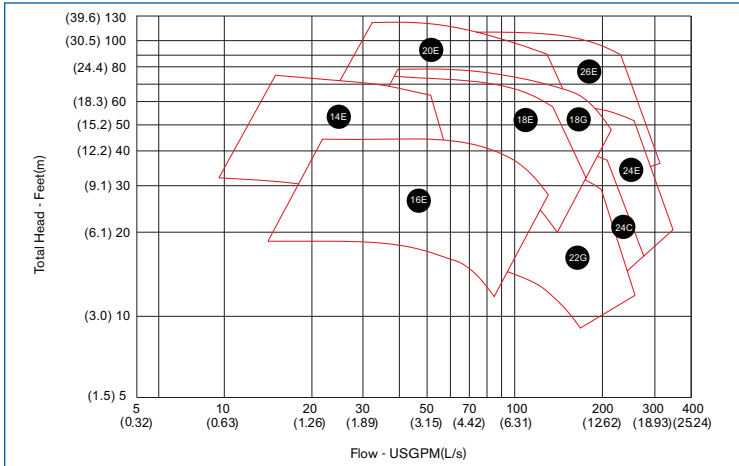

PiB 4380 IVS						
Performance Curve	Model	Part Number			Inlet & Outlet (ANSI 125)	HP
		208 Volts	575 Volts	460 Volts		
14E	4380IVS-1508F-1.5/4	4380V08AI-083	4380V08AI-068	4380V08AI-081	1.5"x1.5"	1.5
16E	4380IVS-2206F-1.5/4	4380V06BI-083	4380V06BI-068	4380V06BI-081	2"x2"	1.5
18E	4380IVS-2208F-3.0/4	4380V08BO-083	4380V08BO-068	4380V08BO-081	2"x2"	3
18G	4380IVS-2208F-5.0/4	4380V08BR-083	4380V08BR-068	4380V08BR-081	2"x2"	5
20E	4380IVS-2210F-5.0/4	4380V10AR-083	4380V10AR-068	4380V10AR-081	2"x2"	5
22G	4380IVS-3306F-2.0/4	4380V06CL-083	4380V06CL-068	4380V06CL-081	3"x3"	2
24C	4380IVS-3308F-3.0/4	4380V08CO-083	4380V08CO-068	4380V08CO-081	3"x3"	3
24E	4380IVS-3308F-5.0/4	4380V08CR-083	4380V08CR-068	4380V08CR-081	3"x3"	5
26E	4380IVS-3310F-7.5/4	4380V10BV-083	4380V10BV-068	4380V10BV-081	3"x3"	7.5

PiB 4360

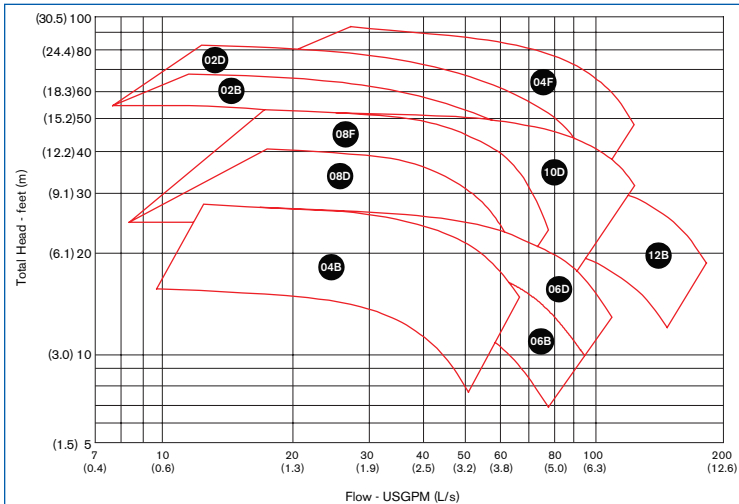

PiB 4360					
Performance Curve	Model	Part Number		Inlet & Outlet (NPT)	HP
		208-230/460 Volts	575 Volts		
02B	4360B-1205T-1.5/2	4360B00AH-083	4360B00AH-068	1.25"x1.25"	① 1.5
02D	4360B-1205T-2.0/2	4360B00AJ-083	4360B00AJ-068	1.25"x1.25"	① 2
04B	4360B-1505T-0.5/4	4360B00BC-062 (115/230V only)		1.5"x1.5"	② 0.5
04F	4360B-1505T-3.0/2	4360B00BM-083	4360B00BM-068	1.5"x1.5"	① 3
06B	4360B-2205T-0.5/4	4360B00CC-062 (115/230V only)		2"x2"	② 0.5
06D	4360B-2205T-0.7/4	4360B00CD-068	4360B00CD-083	2"x2"	② 1.5
08D	4360D-1507T-1.0/4	4360D00AG-083	4360D00AG-068	1.5"x1.5"	1
08F	4360D-1507T-1.5/4	4360D00AI-083	4360D00AI-068	1.5"x1.5"	1.5
10D	4360D-2207T-2.0/4	4360D00BL-083	4360D00BL-068	2"x2"	2
12B	4360D-3307T-1.5/4	4360D00CI-083	4360D00CI-068	3"x3"	1.5

PiB 4380

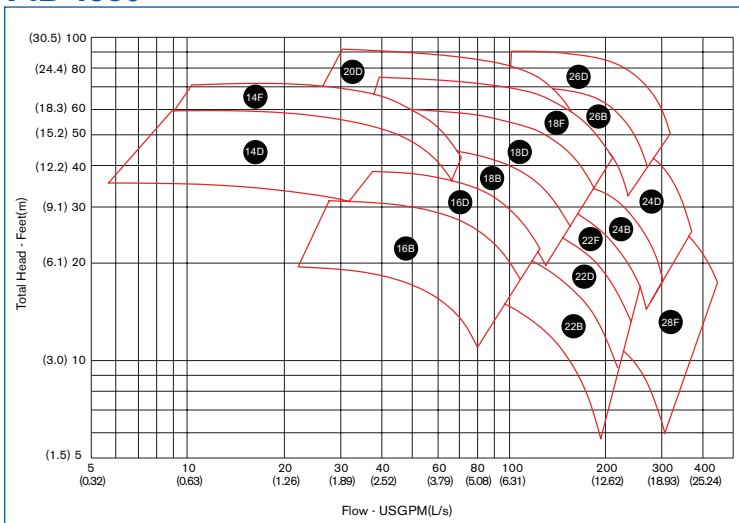

PiB 4380					
Performance Curve	Model	Part Number		Inlet & Outlet (ANSI 125)	HP
		208-230/460 Volts	575 Volts		
14D	4380-1508F-1.5/4	4380008AI-083	4380008AI-068	1.5"x1.5"	1.5
14F	4380-1508F-2.0/4	4380008AL-083	4380008AL-068	1.5"x1.5"	2
16B	4380-2206F-1.0/4	4380006BG-083	4380006BG-068	2"x2"	1
16D	4380-2206F-1.5/4	4380006BI-083	4380006BI-068	2"x2"	1.5
18B	4380-2208F-2.0/4	4380008BL-083	4380008BL-068	2"x2"	2
18D	4380-2208F-3.0/4	4380008BO-083	4380008BO-068	2"x2"	3
18F	4380-2208F-5.0/4	4380008BR-083	4380008BR-068	2"x2"	5
20D	4380-2210F-5.0/4	4380010AR-083	4380010AR-068	2"x2"	5
22B	4380-3306F-1.0/4	4380006CG-083	4380006CG-068	3"x3"	1
22D	4380-3306F-1.5/4	4380006CI-083	4380006CI-068	3"x3"	1.5
22F	4380-3306F-2.0/4	4380006CL-083	4380006CL-068	3"x3"	2
24B	4380-3308F-3.0/4	4380008CO-083	4380008CO-068	3"x3"	3
24D	4380-3308F-5.0/4	4380008CR-083	4380008CR-068	3"x3"	5
26B	4380-3310F-5.0/4	4380010BR-083	4380010BR-068	3"x3"	5
26D	4380-3310F-7.5/4	4380010BV-083	4380010BV-068	3"x3"	7.5
28F	4380-4406F-3.0/4	4380006DO-083	4380006DO-068	4"x4"	3

Notes: All motors are 3-phase 1800 RPM except:

- ① 3600 RPM
- ② 1-phase

PiB 4360 & 4380 Series

► Series 4360

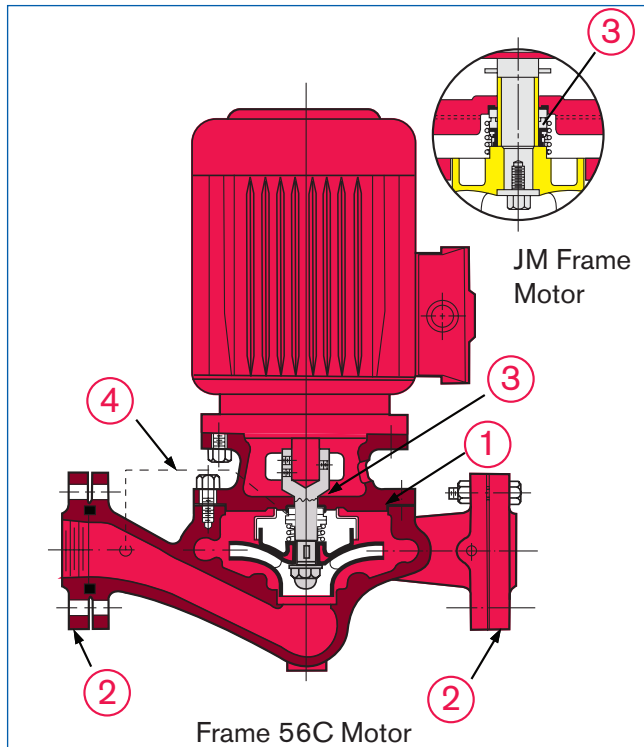

► Design Features

- ① Armstrong VIL pumps are easy to service. A radially split casing permits removal of the motor and pump rotating assembly, without removing the pump casing from the line.
- ② Easy removal of complete pump from the line when necessary, due to companion flanges, supplied with the pump.
- ③ Inside type mechanical seal with Silicon Carbide seat can be serviced without breaking pipe connections.
- ④ Flush and vent connection removes entrained air and ensures constant flow of liquid to the seal face at all times.
 - Equal suction and discharge connections result in simplified piping design and installation.
 - Fewer maintenance and servicing problems due to bearing-free pump design.

► Series 4380

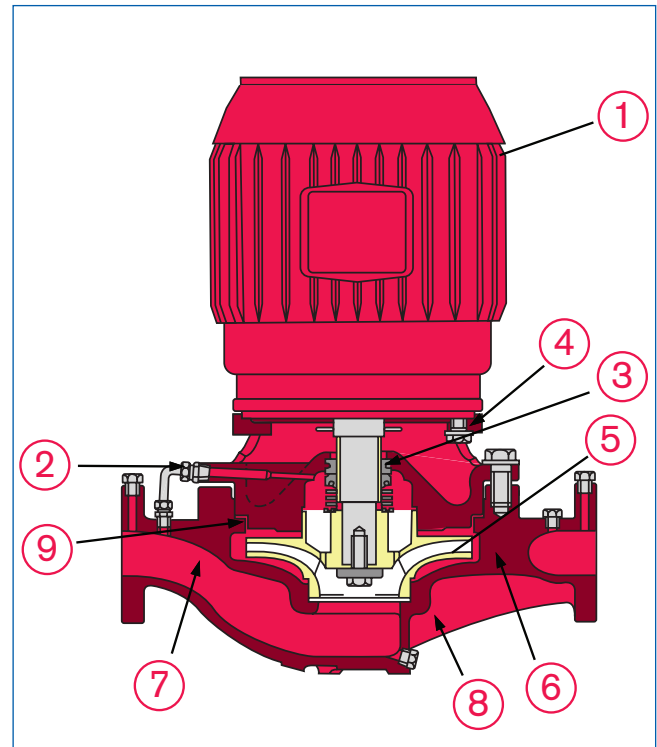

► Design Features

- ① Motor is face mounted to reduce components and simplify design.
- ② Flush and vent connection removes entrained air and ensures constant flow of liquid to the seal face at all times.
- ③ Inside type mechanical seal with Silicon Carbide seat can be serviced without breaking pipe connections.
- ④ Heavy cylindrical bracket with 360° register on both flanges provides a rigid union of pump and motor.
- ⑤ Dynamically balanced impeller assures smooth vibration-free operation.
- ⑥ Radially split casing with equal suction and discharge flange sizes. Separate tapped openings for gauge, flush and drain connections.
- ⑦ Liberal inlet passageways and straightening vanes provide optimum suction performance and quiet operation.
- ⑧ Ribs are integrally cast in the pump casing, to provide added strength and rigidity. Machined surface to accept floor support when specified.
- ⑨ Confined casing gasket to meet stringent industrial temperature and pressure applications.

► Dimensions

PiB 4380 IVS					
Model	Dimensions - inches (mm)				Weight lbs (kg)
	X	Y	H	D	
4380IVS-1508F-1.5/4	16.00 (406)	17.09 (434)	21.36 (543)	4.8 (122)	192 (87.3)
4380IVS-2206F-1.5/4	15.00 (381)	15.92 (404)	21.35 (542)	4.88 (124)	181 (82.3)
4380IVS-2208F-3.0/4	18.00 (457)	17.80 (452)	21.86 (555)	5.20 (132)	233 (105.9)
4380IVS-2208F-5.0/4	18.00 (457)	17.80 (452)	21.86 (555)	5.20 (132)	243 (110.5)
4380IVS-2210F-5.0/4	19.00 (483)	18.75 (476)	21.86 (555)	5.35 (136)	276 (125.5)
4380IVS-3306F-2.0/4	18.00 (457)	18.17 (462)	21.35 (542)	6.06 (154)	197 (89.5)
4380IVS-3308F-3.0/4	22.00 (559)	18.75 (476)	21.86 (555)	6.31 (160)	259 (117.7)
4380IVS-3308F-5.0/4	22.00 (559)	18.75 (476)	21.86 (555)	6.31 (160)	269 (122.3)
4380IVS-3310F-7.5/4	21.00 (533)	21.37 (543)	29.09 (739)	5.40 (137)	382 (173.6)

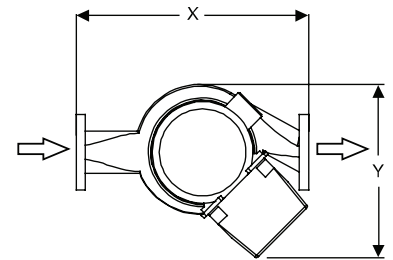
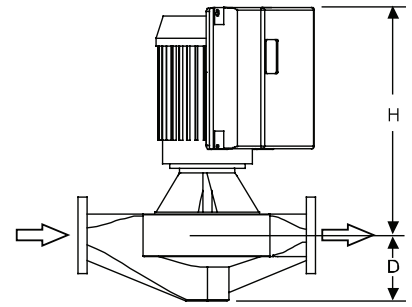

PiB 4360					
Model	Dimensions - inches (mm)				Weight lbs (kg)
	X	Y	H	D	
4360B-1205T-1.5/2	11.50 (292)	8.75 (222)	12.75 (324)	3.56 (90)	42 (19.0)
4360B-1205T-2.0/2	11.50 (292)	8.75 (222)	13.13 (334)	3.56 (90)	47 (21.3)
4360B-1505T-0.5/4	11.63 (295)	8.75 (222)	12.75 (324)	3.56 (90)	43 (19.5)
4360B-1505T-3.0/2	11.63 (295)	8.75 (222)	13.13 (334)	3.56 (90)	58 (26.3)
4360B-2205T-0.5/4	11.75 (298)	8.88 (226)	12.75 (324)	3.50 (89)	49 (22.2)
4360B-2205T-0.7/4	11.75 (298)	8.88 (226)	12.75 (324)	3.50 (89)	51 (23.1)
4360D-1507T-1.0/4	13.50 (343)	10.75 (273)	13.75 (349)	3.25 (83)	110 (49.9)
4360D-1507T-1.5/4	13.50 (343)	10.75 (273)	14.75 (375)	3.25 (83)	115 (52.2)
4360D-2207T-2.0/4	14.00 (356)	11.13 (283)	14.75 (375)	3.50 (89)	120 (54.4)
4360D-3307T-1.5/4	18.00 (457)	13.13 (334)	14.81 (376)	4.50 (114)	130 (59.0)

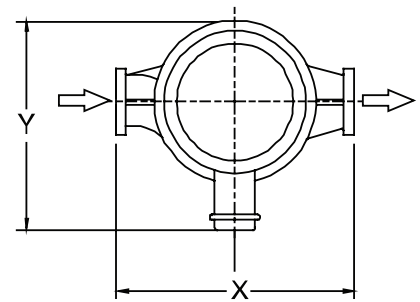
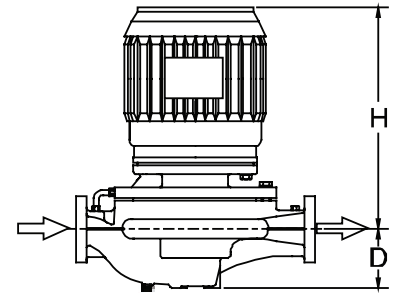

For exact installation data please contact factory for certified dimensions.

PiB 4360 & 4380 Series

PiB 4380					
Model	Dimensions - inches (mm)				Weight lbs (kg)
	X	Y	H	D	
4380-1508F-1.5/4	16.00 (406)	11.75 (298)	15.75 (400)	5.75 (146)	156 (70.8)
4380-1508F-2.0/4	16.00 (406)	11.75 (298)	15.75 (400)	5.75 (146)	156 (70.8)
4380-2206F-1.0/4	15.00 (381)	10.63 (270)	14.75 (375)	4.88 (124)	140 (63.5)
4380-2206F-1.5/4	15.00 (381)	10.63 (270)	15.75 (400)	4.88 (124)	145 (65.8)
4380-2208F-2.0/4	18.00 (457)	11.75 (298)	15.75 (400)	5.13 (130)	172 (78.0)
4380-2208F-3.0/4	18.00 (457)	12.75 (324)	20.13 (511)	5.13 (130)	187 (84.8)
4380-2208F-5.0/4	18.00 (457)	12.75 (324)	20.13 (511)	5.13 (130)	212 (96.2)
4380-2210F-5.0/4	19.00 (483)	13.75 (349)	20.13 (511)	5.38 (137)	245 (111.1)
4380-3306F-1.0/4	18.00 (457)	11.88 (302)	14.75 (375)	6.00 (152)	156 (70.8)
4380-3306F-1.5/4	18.00 (457)	11.88 (302)	6.00 (152)	6.00 (152)	161 (73.0)
4380-3306F-2.0/4	18.00 (457)	11.88 (302)	15.75 (400)	6.00 (152)	161 (73.0)
4380-3308F-3.0/4	22.00 (559)	13.88 (253)	20.13 (511)	6.38 (162)	213 (96.6)
4380-3308F-5.0/4	22.00 (559)	13.88 (253)	20.13 (511)	6.38 (162)	238 (108.0)
4380-3310F-5.0/4	21.00 (533)	14.25 (362)	20.13 (511)	6.25 (159)	282 (128.0)
4380-3310F-7.5/4	21.00 (533)	16.63 (422)	25.63 (651)	6.25 (159)	331 (150.1)
4380-4406F-3.0/4	22.00 (559)	13.88 (353)	20.38 (518)	7.75 (197)	213 (96.6)

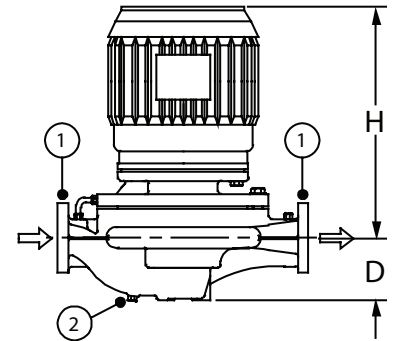

- ① 1/4" NPT GAUGE TAPPINGS
- ② 1/4" NPT DRAIN

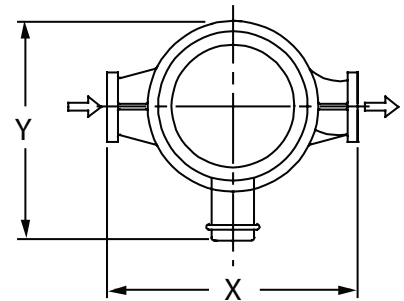

► Typical Specifications

Pump Type:	Vertical In-Line
Max. Working Pressure:	175 psi @ 140°F
Max. Working Temperature:	►250°F (121°C) ►225°F (107°C) (4360 only)
End Connections:	ANSI 125 Flanges or NPT with Companion Flanges (4360 only)
Primary Seal:	Armstrong Type 2A Mechanical Inside Single Spring
Max. Flow:	450 USgpm (28.4 L/s)
Max. Head:	120 ft (36 m)
Motor Enclosure:	►Open Drip Proof (ODP) (4360B Only) ►Totally Enclosed Fan Cooled (TEFC)
Motor Efficiency:	►Standard (4360B) ►Energy Efficient 12.11(4360D/4380) ►NEMA Premium 12.12(4380IVS)
Motor Frames:	JM/JP/56C

► Materials of Construction

Casing:	Cast Iron
Impeller:	Bronze
Casing Gasket:	Fiber
Adaptor Bracket:	Cast Iron
Motor Shaft:	Carbon Steel
PiB 4360B	Stainless Steel
Stub Shaft:	56C motors only
PiB 4360D/4380	Stainless Steel
Stub Shaft:	56C motors only
Shaft Sleeve:	Stainless Steel (PiB 4360D & PiB 4380 only)
Water Slinger:	Neoprene (PiB 4360D/4380 only)
Rotating Seal Face:	Resin Bonded Carbon
Stationary Seal Face:	Silicon Carbide
Secondary Seal:	Buna-N (PiB 4360B) EPDM

► Typical Applications

	Constant Speed PiB	Variable Speed PiB IVS
Heating Applications		
Primary Pumps	•	•
Boiler Recirculation	•	•*
Mixing Loops		•
Heat Exchanger Applications	•	•*
Geothermal	•	•
Domestic Hot Water Recirculation	•	•
Domestic Hot Water Production	•	•
Cooling Applications		
Primary Chilled Water	•	•
Secondary Chilled Water	•	•
Cooling Tower	•	•
Heat Exchanger Applications	•	•*
Fan Coils	•	•
Thermal Energy Storage		•
Condenser Water	•	•
Geothermal	•	•
General Applications		
Filtration Systems		•
Fountains	•	•
Spray Washers	•	•

*PiB IVS units can serve these applications when set to operate at a fixed speed.

► Pressure and Temperature

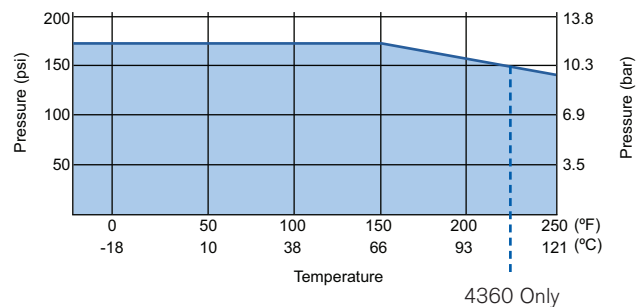

S. A. Armstrong Limited
23 Bertrand Avenue
Toronto, Ontario
Canada, M1L 2P3
T: 416-755-2291
F: 416-759-9101

Armstrong Pumps Inc.
93 East Avenue
North Tonawanda, New York
U.S.A., 14120-6594
T: 716-693-8813
F: 716-693-8970

Armstrong Integrated Limited
Wenlock Way
Manchester
United Kingdom, M12 5JL
T: +44 (0) 8444 145 145
F: +44 (0) 8444 145 146



© S. A. Armstrong Limited 2010

For Armstrong locations worldwide, please visit www.armstrongintegrated.com