

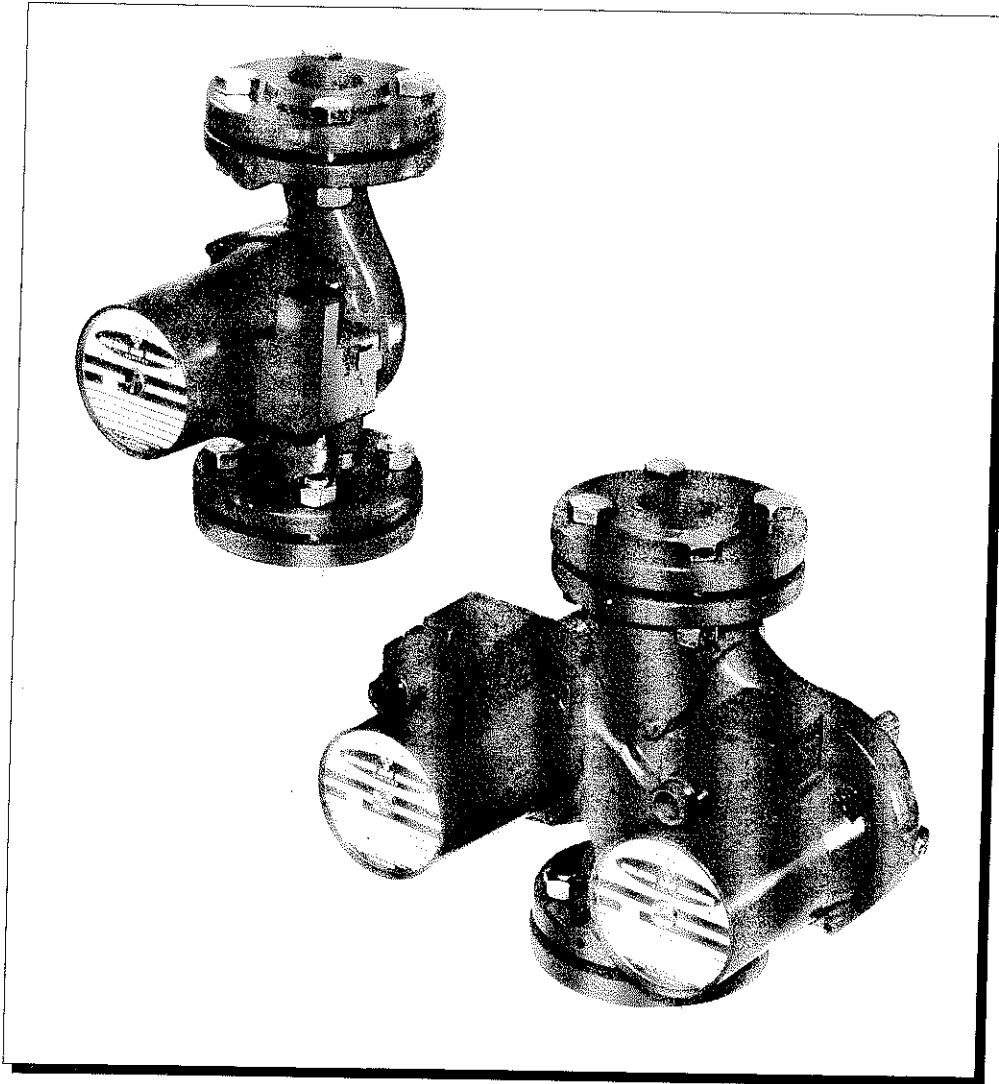

A wealth of experience



Starkan

Glandless Circulators - Single and Twin Units



Certificate No. 930846

SELECTION CURVES FOR STARKAN SINGLE AND TWIN CIRCULATORS

Preliminary Selection - on water SG = 1.0
Single circulator at 4-pole motor speed
nominal 1400 rpm

Each pump in a twin unit can deliver approx. 90% of
the single STARKAN flow

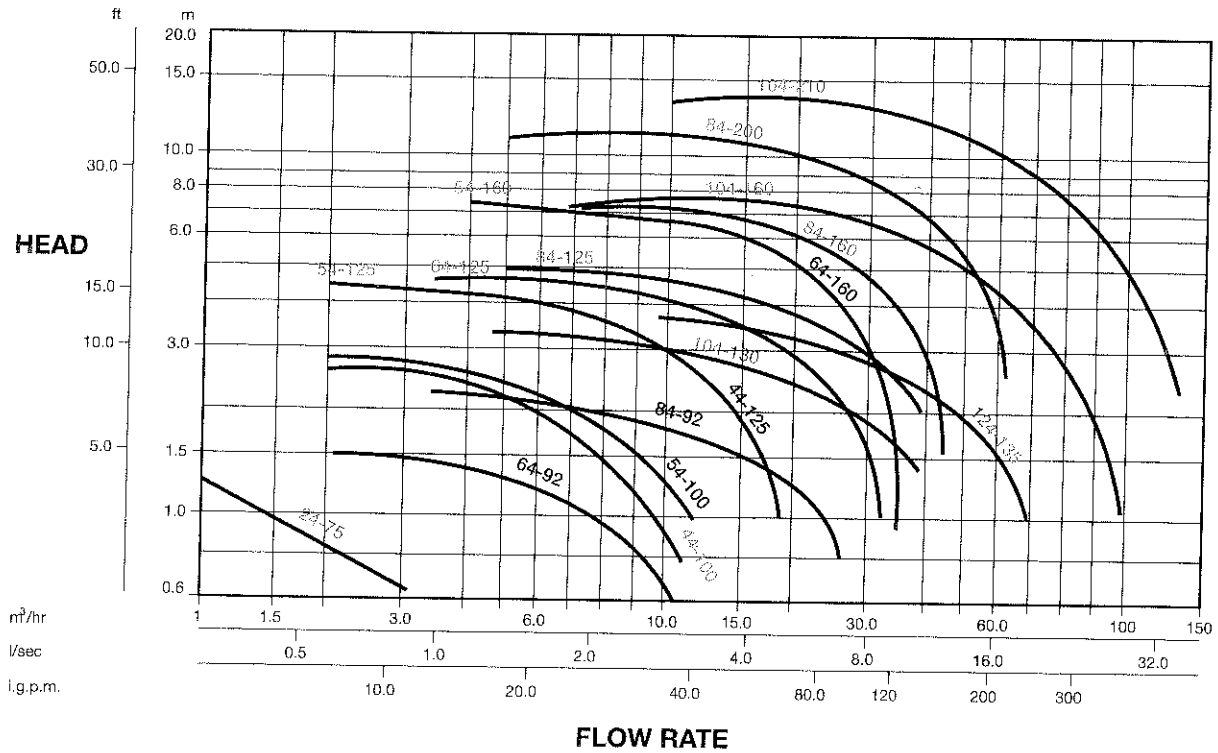

Preliminary Selection - on water SG = 1.0
Single circulator at 2-pole motor speed
nominal 2800 rpm

Each pump in a twin unit can deliver approx. 90% of
the single STARKAN flow

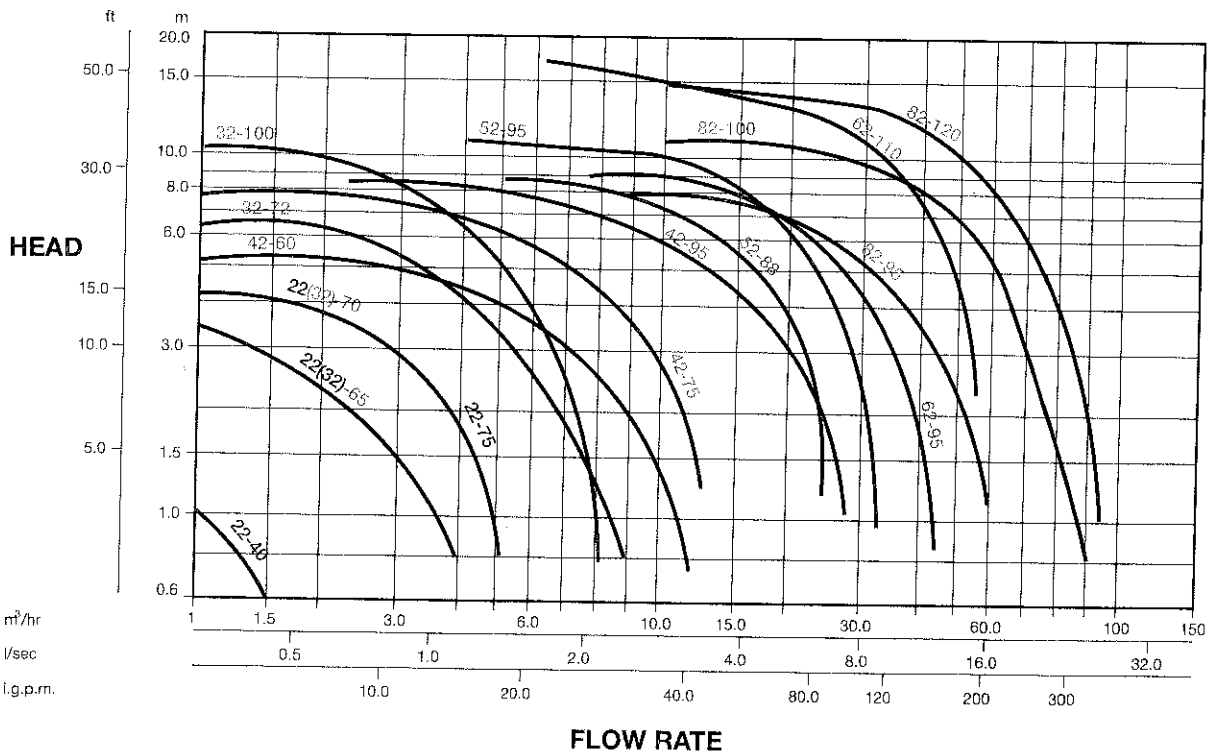

Sizes in blue are Starkan circulators which are
available in single and twin units.
Both pumps together in a twin unit can deliver
approx. 1.8 time the single unit.

Confirm selection with reference to the individual
STARKAN selection curve from the following pages

SELECTION CURVES FOR STARKAN SINGLE AND TWIN CIRCULATORS

22-40 Options GS 2-pole, single phase

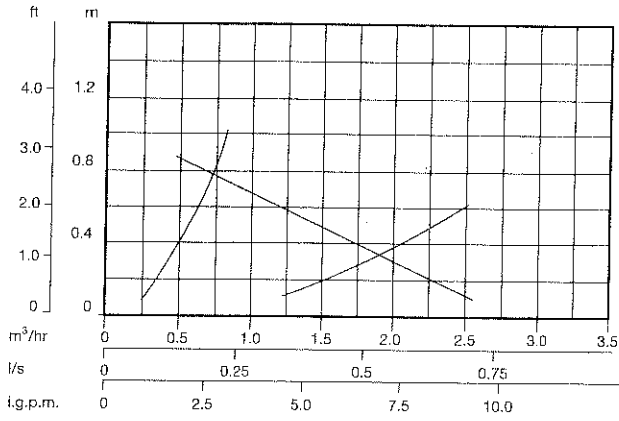

22-65 Options CS, GS 2-pole, single phase
32-65 Options CD 2-pole, single phase

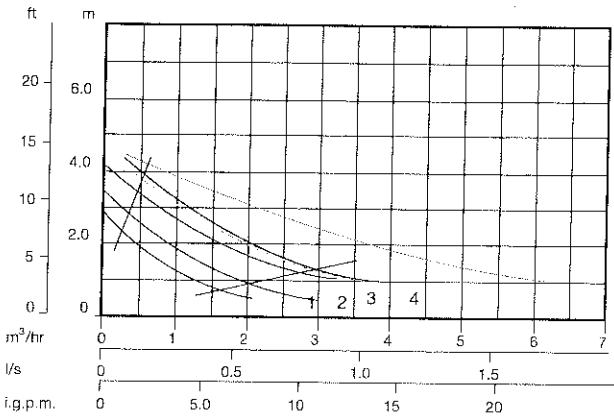

22-70 Options CS, GS 2-pole, single phase
32-70 Options CD 2-pole, 1 & 3 phase

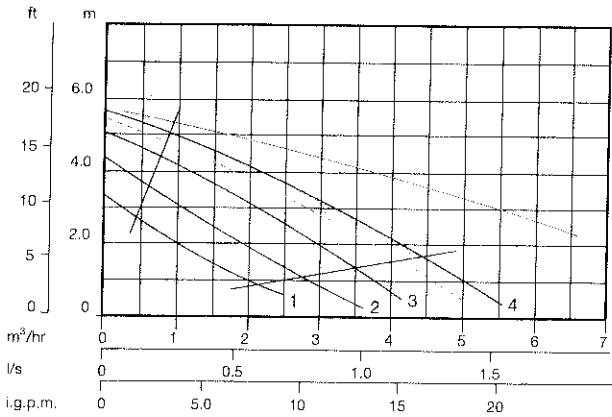

22-75 Options CS, GS 2-pole, 3-phase
24-75 Options CS, GS 2-pole, 3-phase

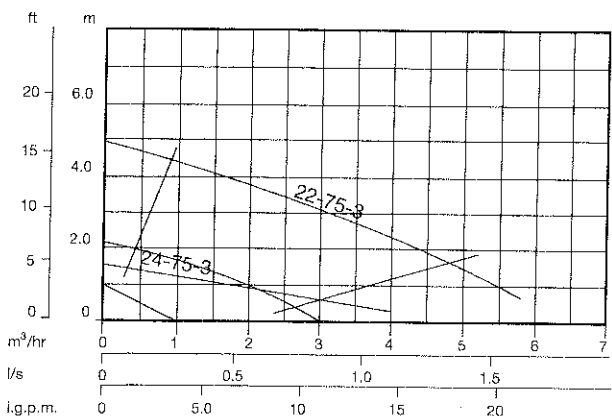

32-72 Options CS,CD,GS 2-pole, 1&3 phase

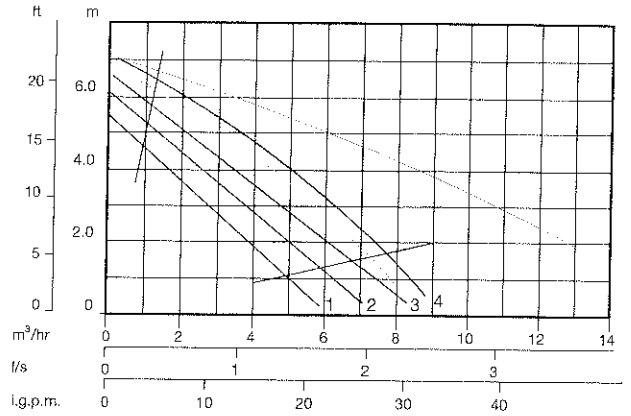

32-100 Options CS,CD,GS 2-pole, 1&3 phase

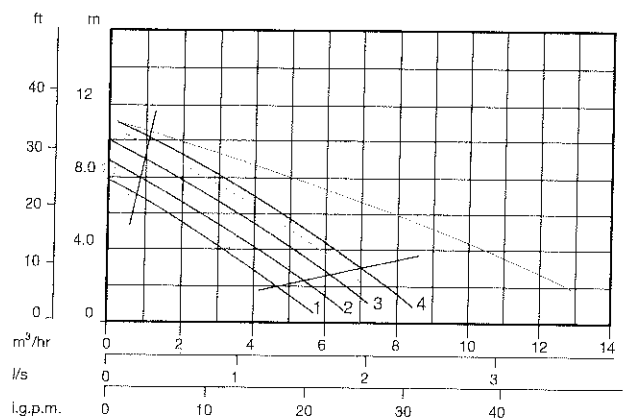

42-60 Options CS,CD,GS 2-pole, 1&3 phase

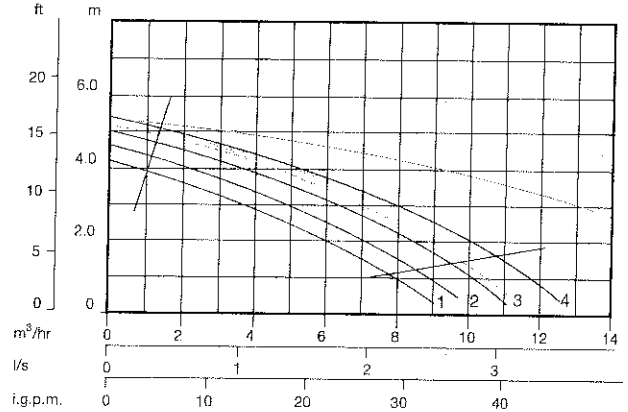

42-75 Options CS,CD,GS 2-pole, 1&3 phase

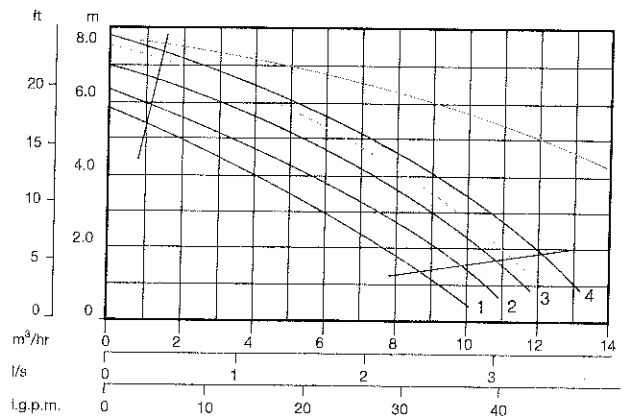

Black curves: STARKAN Single Circulators at speeds 1 (Lowest) to 4 (Highest, i.e. synch. motor) speeds.

Select circulators from the shaded zone.

Blue curves: Twin STARKAN at highest speed. Full line both pumps in parallel, broken line one pump running.

SELECTION CURVES FOR STARKAN SINGLE AND TWIN CIRCULATORS

42-95 Options CS,CD,GS 2-pole, 1&3 phase

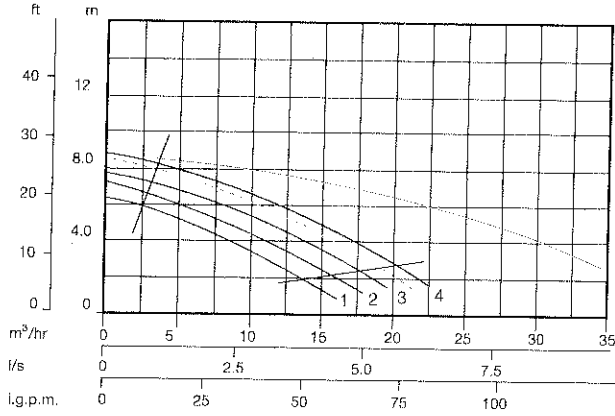

52-95 Options CS,CD,GS 2-pole, 1&3 phase

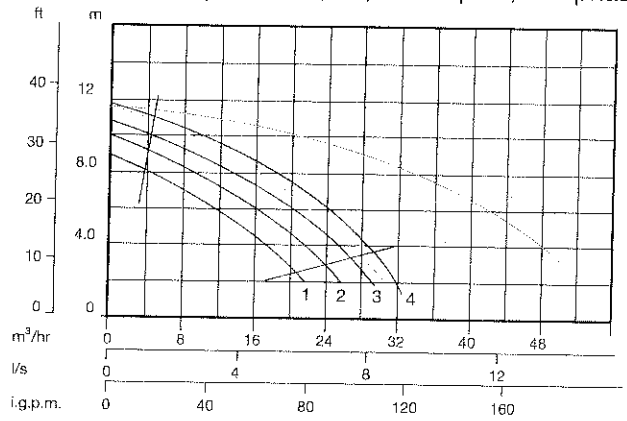

44-100 Options CS,CD,GS 4-pole, 1&3 phase

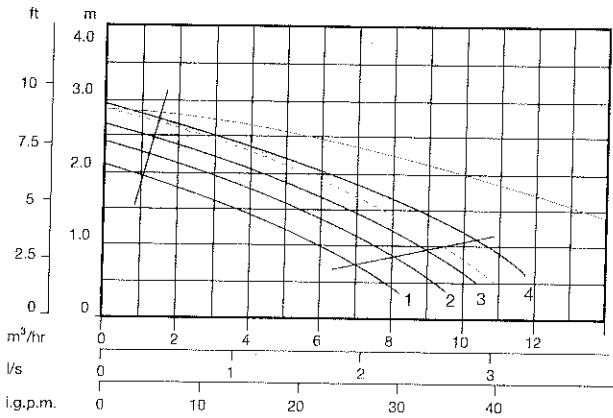

54-100 Options CS 4-pole, 1&3 phase

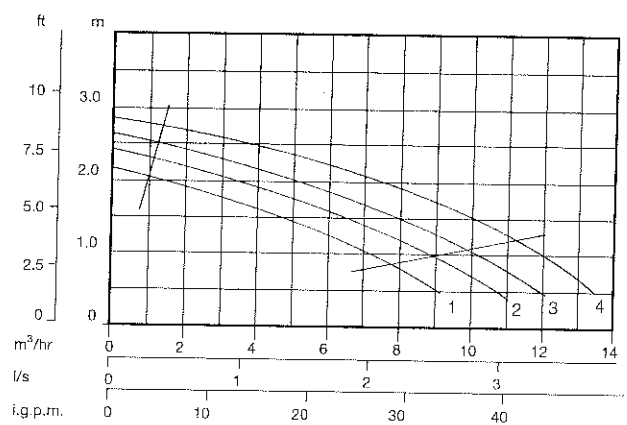

44-125 Options CS 4-pole, 1&3 phase

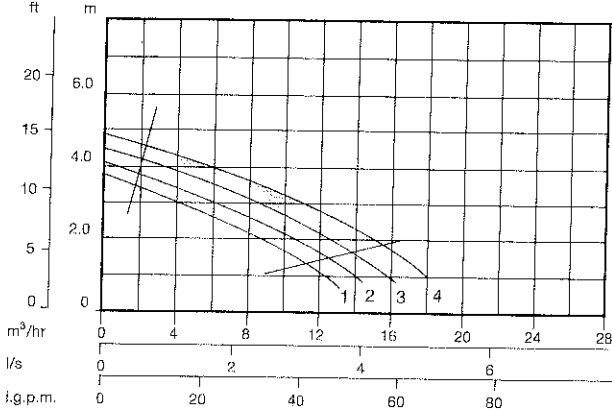

54-125 Options CS,CD,GS 4-pole, 1&3 phase

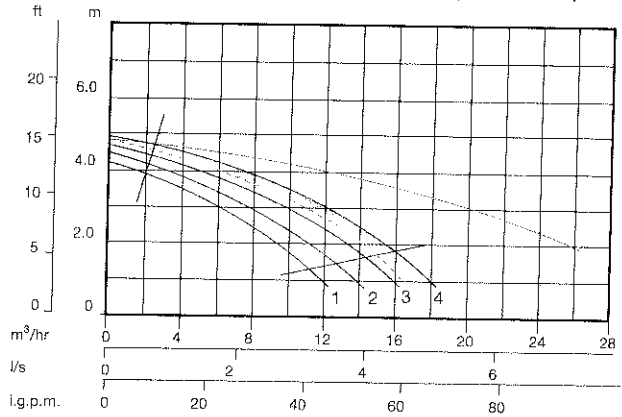

52-88 Options CS,CD,GS 2-pole, 1&3 phase

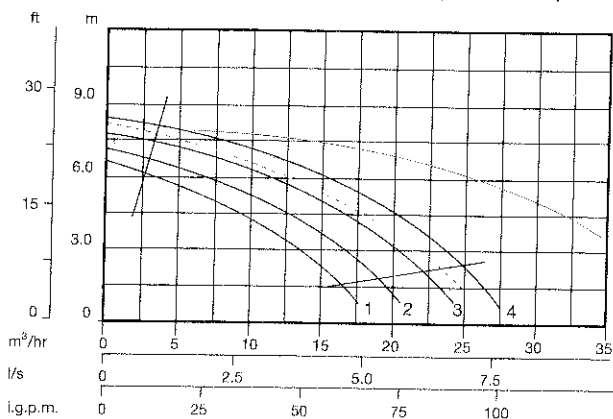

54-160 Options CS,CD 4-pole, 1&3 phase

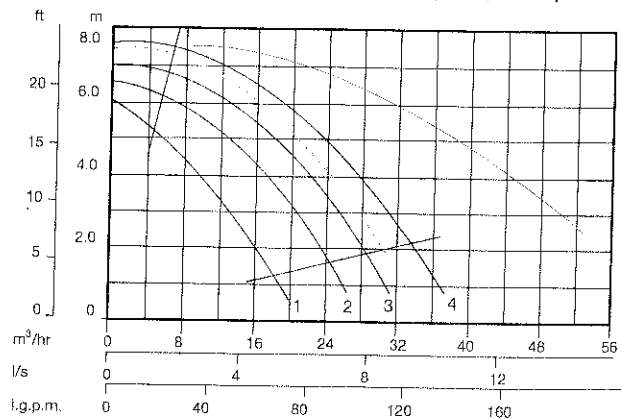

Black curves: STARKAN Single Circulators at speeds 1 (Lowest) to 4 (Highest, i.e. synch. motor) speeds.
 Select circulators from the shaded zone.
 Blue curves: Twin STARKAN at highest speed. Full line both pumps in parallel, broken line one pump running.

SELECTION CURVES FOR STARKAN SINGLE AND TWIN CIRCULATORS

62-95 Options CS,CD,GS 2-pole, 1&3 phase

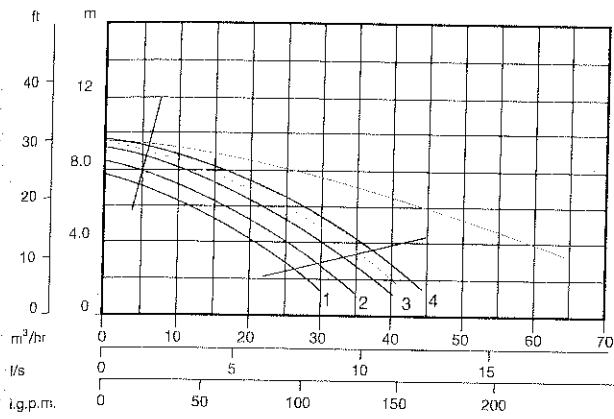

64-160 Options CS 4-pole, 1&3 phase

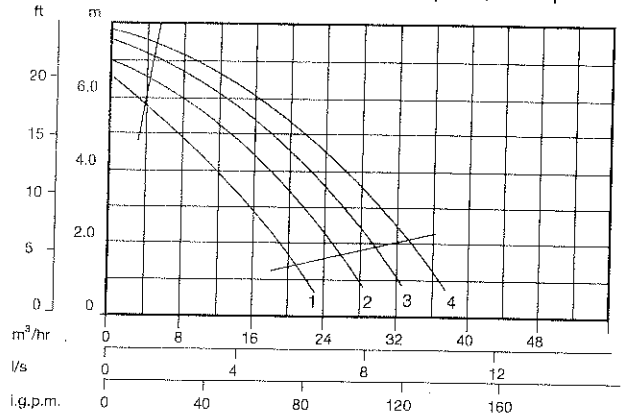

62-110 Options CS,CD 2-pole, 1&3 phase

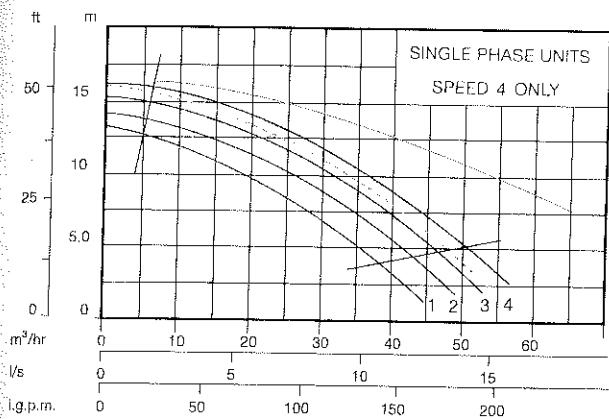

82-95 Options CS,CD 2-pole, 1&3 phase

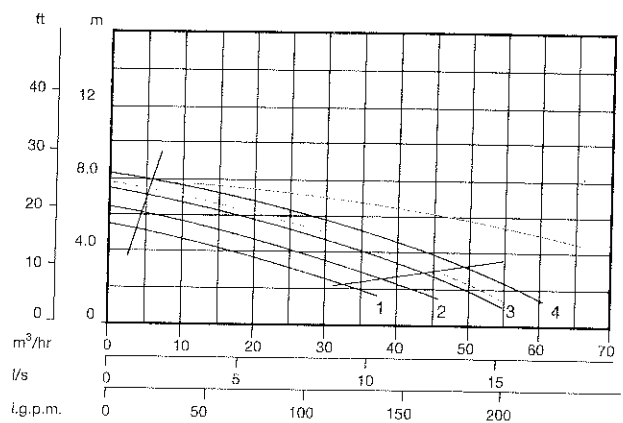

64-92 Options CS 4-pole, 1&3 phase

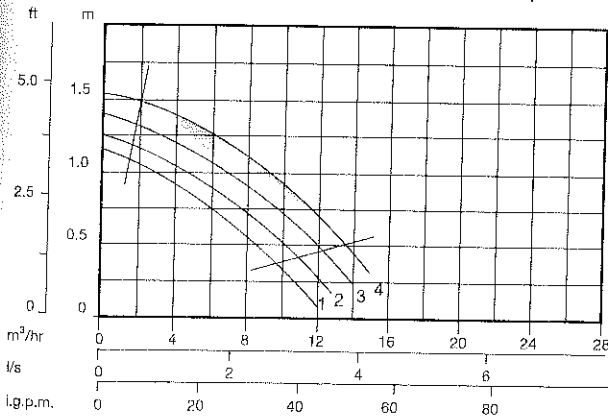

82-100 Options CS,CD 2-pole, 1&3 phase

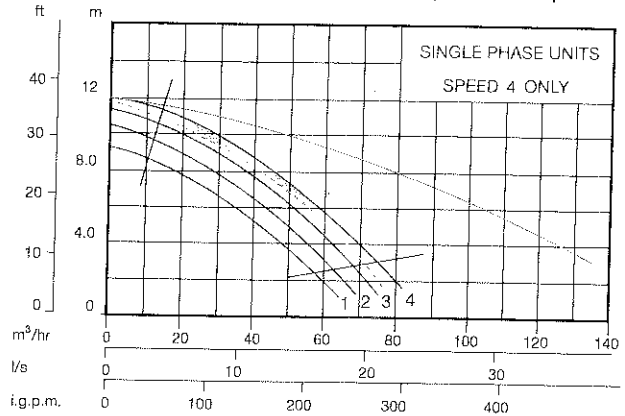

64-125 Options CS,CD,GS 4-pole, 1&3 phase

64-135 Options CS 4-pole, 3 phase

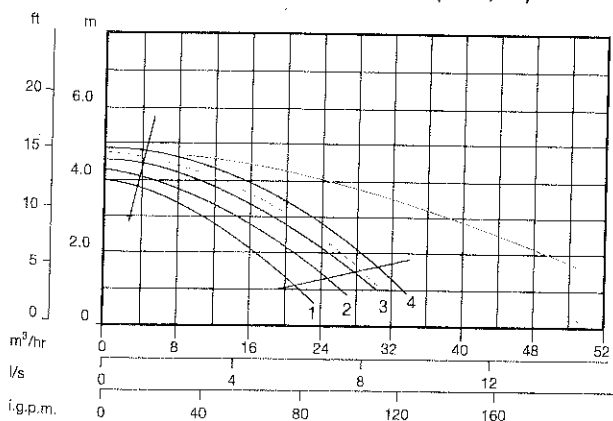

82-120 Options CS,CD 2-pole, 1&3 phase

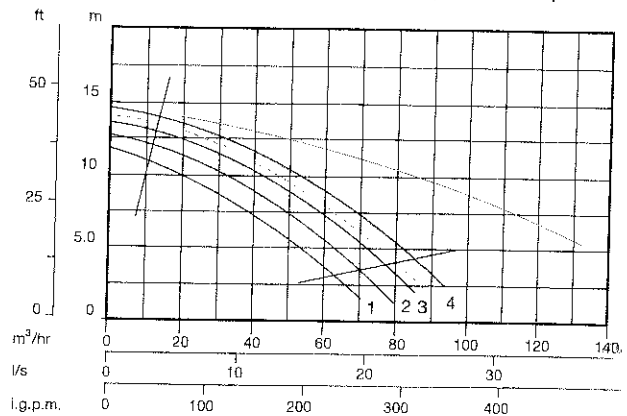

Black curves: STARKAN Single Circulators at speeds 1 (Lowest) to 4 (Highest, i.e. synch. motor) speeds.
 Select circulators from the shaded zone.
 Blue curves: Twin STARKAN at highest speed. Full line both pumps in parallel, broken line one pump running.

Model	Minimum Inlet Suction Head (Metres)	Starting Current at Maximum Speed	
		240-1-50	415-3-50
22-40	1.5	0.78	-
22-65	1.5	1.23	-
22-70	2.5	1.53	-
22-75	2.5	-	0.72
24-75	2.0	-	0.52
32-65	2.5	1.23	-
32-70	2.5	1.53	0.9
32-100	2.5	4.0	1.3
42-60	2.5	2.88	1.5
42-75	2.5	3.9	1.53
42-95	2.5	5.2	2.5
44-100	2.0	2.91	1.86
44-125	2.0	5.58	3.09
52-88	2.5	5.2	2.5
52-95	3.0	10.4	4.4
54-100	2.0	2.91	1.86
54-125	2.0	3.4	1.84
54-160	2.0	15.6	6.0

Model	Minimum Inlet Suction Head (Metres)	Starting Current at Maximum Speed	
		240-1-50	415-3-50
62-95	3.0	10.4	4.4
62-110	3.0	33.9	11.4
64-92	2.0	2.91	1.86
64-125	2.0	7.8	4.2
64-136	2.0	7.8	4.2
64-160	2.0	15.6	6.0
82-95	3.0	18.6	6.6
82-100	3.0	22.0	7.32
82-120	3.0	-	10.06
84-92	2.0	5.58	3.09
84-125	2.0	8.26	3.85
84-160	2.0	-	8.07
84-200	2.0	-	13.2
104-130	2.0	7.8	4.2
104-160	2.0	-	11.07
104-210	2.0	-	21.78
124-135	2.0	15.6	6.0

Venting

Before start up, circulators must be vented by removing the plug positioned in the centre of the nameplate. Circulators for secondary hot water should be vented regularly. Twin circulators in horizontal pipes should be fitted with an automatic air valve to the tapping in the upper circulator.

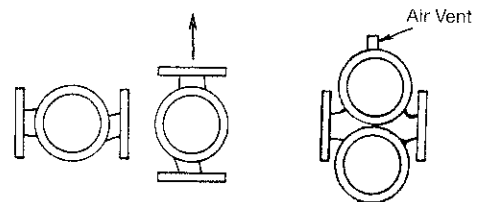

Allowed

Checking the Direction of Rotation

Shaft rotation should be anti-clockwise as indicated by the arrow on the nameplate. Direction of rotation can be checked with the plug removed, which is positioned at the centre of the nameplate.

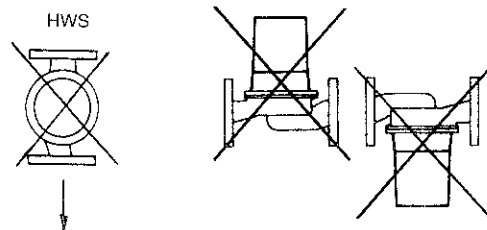

Not Allowed

Mounting

Starkan circulators are renowned for their low noise levels in operation and maintenance free long life. Single head circulators can be installed in horizontal or vertical pipework. The motor should be installed in the horizontal position. Twin circulators are designed for vertical pipework and should only be used in horizontal pipework when an automatic air vent is fitted in the upper pump.

Dimensions

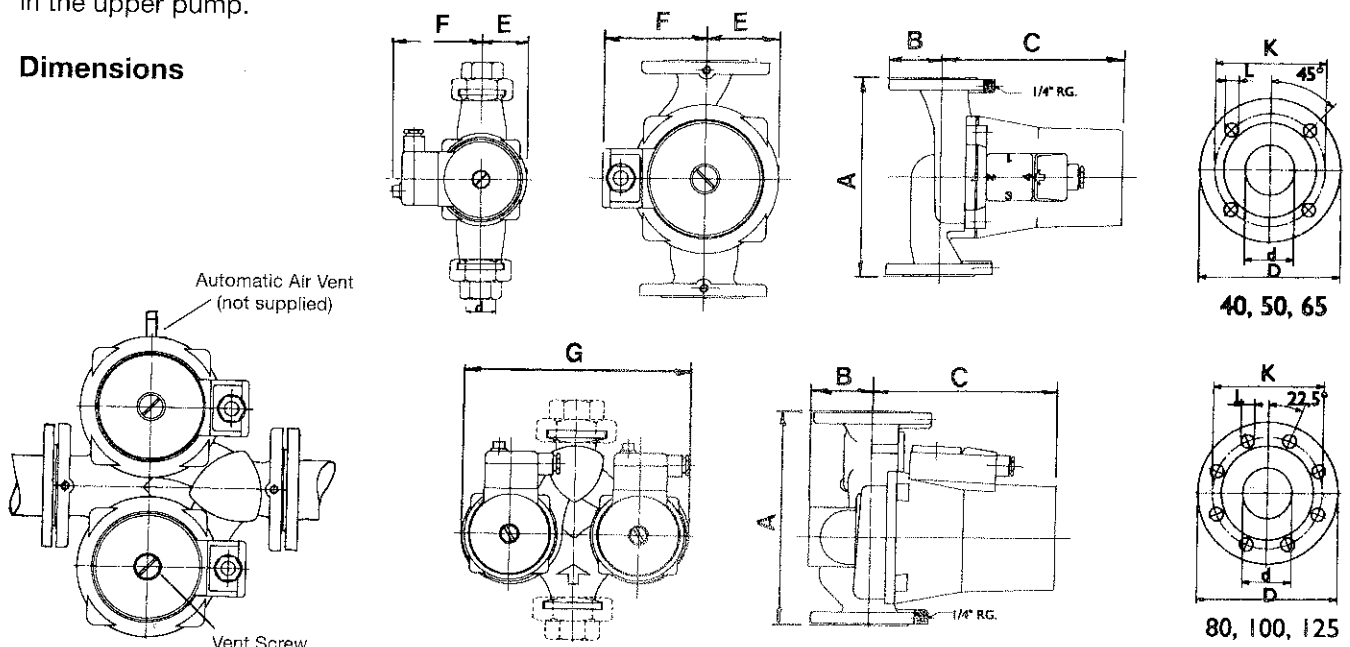

Dimensions

TYPE	A (Twin italics)	B (Twin italics)	C	D	d	E	F	G	FLC Amps 230 - 1 - 50 Single phase				FLC Amps 400 - 3 - 50 Three phase				Watts		Weight Kg		
									1	2	3	4	1	2	3	4	Min	Max	Single Pump	Twin Pump	
22-40	180	-	110	-	3/4" 1"	55	95	-	-	-	-	-	-	-	-	-	-	-	-	-	-
22-65	180/180	30/35	110	-	1"	55	95	245	0.24	0.29	0.35	0.41	0.26	-	-	-	-	-	-	-	2.6
22-70	180/180	30/35	110	-	1.1/4"	55	95	245	0.29	0.38	0.46	0.54	-	-	-	-	-	-	-	-	3.1
22-75	180	-	150	-	1.1/4"	60	85	-	-	-	-	-	-	-	-	-	-	-	-	-	2.9
24-75	180	-	150	-	1"	60	85	-	-	-	-	-	-	-	-	-	-	-	-	-	5.7
32-65	180/180	30/35	110	-	1"	55	95	245	-	-	-	-	-	-	-	-	-	-	-	-	4.5
32-70	180/180	30/35	110	-	1.1/4"	55	95	245	0.29	0.38	0.46	0.54	-	-	-	-	-	-	-	-	6.1
32-72	180/180	30/35	145	-	1.1/4"	55	95	245	0.68	0.85	0.94	0.96	0.23	0.28	0.36	0.50	0.25	52	120	-	6.1
32-100	180/180	32/50	160	-	1.1/4"	65	95	305	1.27	1.31	1.36	1.41	0.4	0.48	0.56	0.74	0.25	75	228	4.5	9.5
42-60	250/250	75/75	150	150	40	75	90	350	0.68	0.85	0.94	0.96	0.23	0.28	0.36	0.50	0.25	64	225	6.3	13.3
42-75	250/250	75/75	160	150	40	75	95	350	1.27	1.31	1.36	1.41	0.4	0.48	0.56	0.74	0.25	64	225	9.8	18.2
42-95	250/250	75/75	200	150	40	75	105	350	2.18	2.45	2.81	2.91	1.04	1.13	1.25	1.36	0.62	65	205	11.1	19.1
44-100	250/250	75/75	160	150	40	65	95	350	0.81	0.88	0.94	0.97	0.23	0.30	0.42	0.62	0.25	193	580	14.2	25
44-125	250	-	205	150	40	95	100	-	1.41	1.54	1.70	1.86	0.76	0.83	0.92	1.03	0.22	65	205	11.7	20.2
52-88	280/280	83/83	200	165	50	85	105	390	2.18	2.45	2.81	2.91	1.04	1.13	1.25	1.36	0.22	65	205	11.7	20.2
52-95	280/280	83/83	230	165	50	95	125	390	4.2	4.67	5.0	5.3	1.43	1.56	1.75	1.95	0.22	65	205	11.7	20.2
54-100	300	-	155	165	50	75	90	-	0.81	0.88	0.94	0.97	0.23	0.30	0.42	0.62	0.25	193	580	14.2	25
54-125	280/280	83/83	200	165	50	85	105	390	0.81	0.88	0.94	0.97	0.23	0.30	0.42	0.62	0.25	193	580	14.2	25
54-160	340/340	85/85	250	165	50	105	125	480	1.41	1.54	1.70	1.86	0.76	0.83	0.92	1.03	0.22	65	205	11.7	20.2
62-95	340/340	93/93	235	185	65	105	125	455	2.58	3.0	4.0	5.2	1.19	1.45	1.71	2.0	0.22	65	205	11.7	20.2
62-110	340/340	93/93	285	185	65	105	125	455	4.2	4.67	5.0	5.3	1.4	1.56	1.75	1.95	0.22	65	205	11.7	20.2
64-92	280	-	170	185	65	80	90	-	-	-	-	-	-	-	-	-	-	-	-	-	33
64-125	340/340	93/93	235	185	65	105	125	455	0.81	0.88	0.94	0.97	0.23	0.30	0.42	0.62	0.25	193	580	14.2	25
64-135	300	93	235	185	65	105	125	455	1.93	2.16	2.37	2.60	1.05	1.16	1.29	1.40	0.22	65	205	11.7	20.2
64-160	370	-	235	185	65	105	125	-	2.58	3.0	4.0	5.2	1.19	1.45	1.71	2.0	0.22	65	205	11.7	20.2
82-95	360/360	100/102	240	200	80	105	125	505	3.8	4.6	5.8	6.2	1.5	1.72	2.0	2.2	0.22	65	205	11.7	20.2
82-100	360/360	100/100	290	200	80	105	125	510	-	-	-	-	-	-	-	-	-	-	-	-	40
82-120	360/360	100/100	290	200	80	105	125	510	-	-	-	-	-	-	-	-	-	-	-	-	40
84-92	330	-	230	200	80	105	125	510	-	-	-	-	-	-	-	-	-	-	-	-	40
84-125	360/360	100/102	240	200	80	105	130	-	1.41	1.54	1.70	1.86	0.76	0.83	0.92	1.03	0.22	65	205	11.7	20.2
84-160	390/360	100/100	290	200	80	110	135	520	2.53	2.65	2.75	3.0	0.9	1.03	1.23	1.59	0.22	65	205	11.7	20.2
84-200	440/440	105/100	290	200	80	105	130	510	-	-	-	-	-	-	-	-	-	-	-	-	40
104-130	380	-	270	220	100	125	125	-	-	-	-	-	-	-	-	-	-	-	-	-	40
104-160	470/485	100/150	292	220	100	135	200	740	1.93	2.16	2.37	2.6	1.06	1.16	1.29	1.4	0.22	65	205	11.7	20.2
104-210	485/485	150/150	355	220	100	135	200	740	-	-	-	-	-	-	-	-	-	-	-	-	40
124-135	450	-	300	250	125	160	160	-	2.58	3.0	4.0	5.2	1.19	1.45	1.71	2.0	0.22	65	205	11.7	20.2

Flanges

d (bore)	PN6		PN10	
	K	I	K	I
40				
50	100	15	110	18
65	110		125	
	130		145	

d (bore)	PN6		PN10	
	K	I	K	I
80				
100				
120				



A wealth of experience

PUMP SIZE	TYPE SPECIFICATIONS			230V 50Hz SINGLE PHASE WIRING				400V 50Hz 3-PHASE WIRING		
	CS	CD	GS	A	B	C	D	E	F	G
22-40				S						
22-65				1						S
22-70				1						S
22-75							S M			S M
24-75							S M			S M
32-65				1						S
32-70				1						S
32-72				1						S
32-100					1			2		
42-60				1				2	2	
42-75					1				2	
42-95						2			2	
44-100					1				2	
44-125						2			2	
52-88						2			2	
52-95						2			2	
54-100					1				2	
54-125						2			2	
54-160						2			2	
62-95						2			2	
62-110						2			2	
64-92					1		S		2	
64-125						2			2	
64-135						2			2	
64-160						2			2	
82-95						2			2	
82-100						2			2	
82-120							S		2	
84-92						2			2	
84-125						2			2	
84-160									2	
84-200									2	
104-130						2			2	
104-160									2	
104-210									2	
124-135						2			2	

Controller & Regulator 1 = Four-speed switch 2 = Four speed plug M = Manual flow regulator S = Single speed

Wiring and thermal overload protection

The motor should be wired to a contactor having a thermal overload trip set for the running speed to protect the motor.

To protect the motor at all speeds, circulators with wiring specifications B,C or F have an internal thermal switch.

This should be connected to a relay interlocked with a contactor.

Certified drawings supplied on request

Note: Improvements in general design and modifications in detail will be embodied for the benefit of clients as and when introduced, consequently this specification is subject to alteration, as may be necessary, without notice.

Manufacturers of : ● Centrifugal Pumps ● Pressurisation Units ● Packaged Pump Sets ● High Pressure Pumps
For Pump Spares, Service and Maintenance Contracts
Telephone: 0161-223-2223

Manchester

Wenlock Way
 West Gorton
 MANCHESTER M12 5JL
 Tel: +44(0) 161-223-2223
 Fax: +44(0) 161-220-9660

London

Unit 2, Princess Mews
 Horace Road
 KINGSTON-U-THAMES KT1 2S2
 Tel: 0181-547-0411
 Fax: 0181-547-0838

Glasgow

Tel: 0141-943-1252

Northern Ireland

C&F Quadrant (NI) Ltd
 Unit 9, Abbey Trading Estate
 Langwood Road, Newton Abbey
 Belfast BT37 9UQ
 Tel: 01232-365555
 Fax: 01232-365566