

# Packaged Booster Sets

HYDROPNEUMATIC SETS Mk IV  
DIRECT TRANSFER SETS Mk IV  
CONSTANT RUN SETS Mk IV

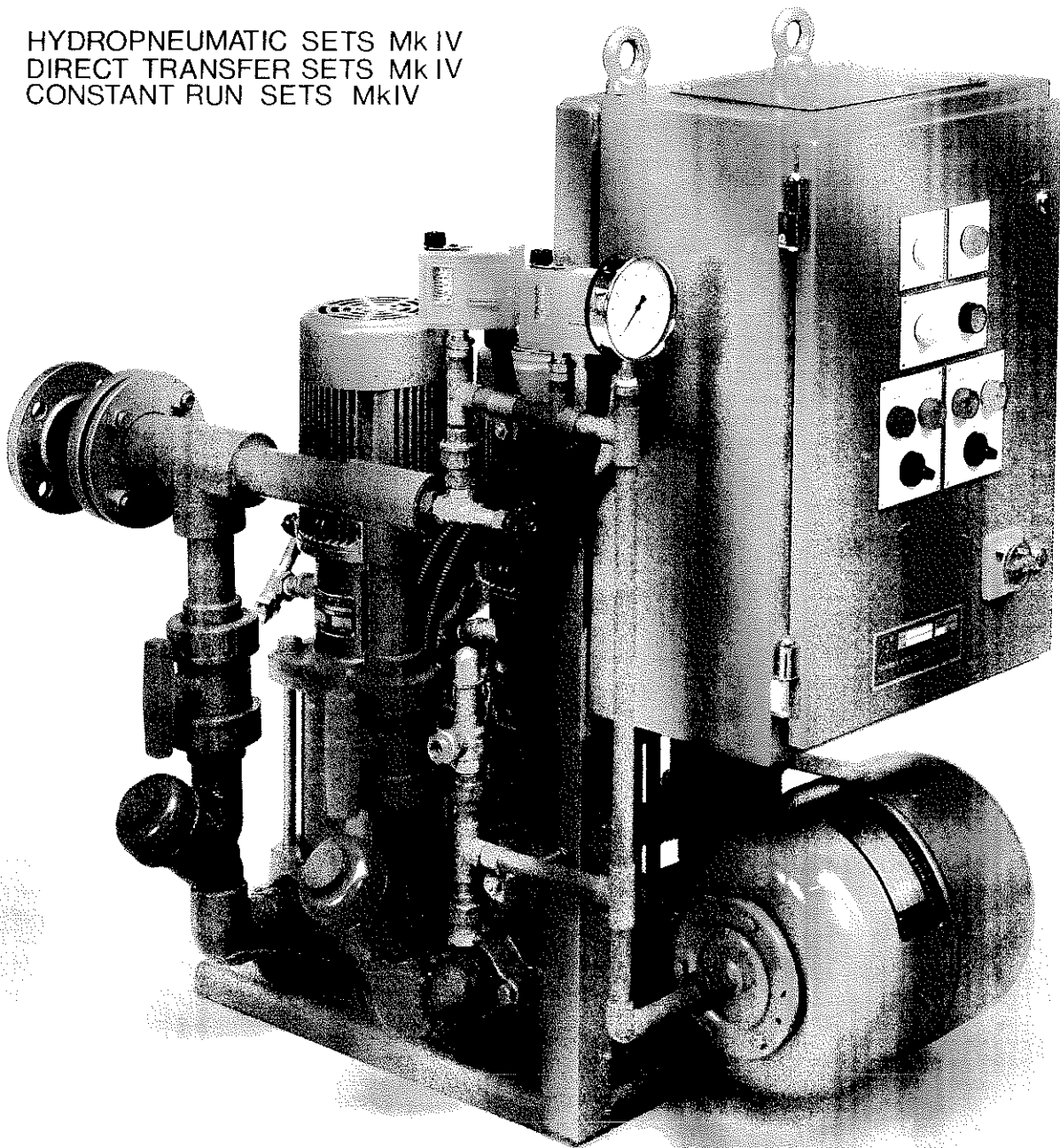

**Holden and Brooke Limited**

Haverford Street, Manchester M12 5JL, England.

Tel: 061-274 4242, Fax: 061-274 3068, Telex: 667318.

## HYDRO-PNEUMATIC BOOSTER SETS

These sets are used for pressurising systems, separated from municipal mains by break tanks.

Sets comprise 2 or 3 pumps, manifolds with isolating and non-return valves, pressure switches, gauge and relief valves, all mounted onto a combination bedplate.

The sets are so designed that on 2 pump sets it is recommended that each pump shall be capable of the full system duty and on 3 pump sets each pump is capable of 50% of full duty, the third pump on these sets being a standby to the other two.

The choice between a 2 or 3 pump set is governed by the interaction between the required flowrate, motor power, price and clients own preference. Within these constraints we will offer the most economical solution.

## DIRECT TRANSFER SETS

These sets are designed to operate with gravity fed cold water system, with or without drinking water headers.

In these systems, water is fed from a mains break tank or direct from the mains, to the pumps situated at low level. The water is then pumped to roof storage tanks, from which it gravitates on demand, to user outlets.

Direct Transfer sets generally would have 2 pumps arranged for duty and support operation, each pump being sized to pass the full duty required. Should a 3 pump set be specified, each pump would be sized to pass 50% of the total set capacity at peak demand.

## OPERATION OF THE SET

The sets are controlled by two float switches fitted into the roof storage tank. The No. 1 switch controls the duty pump and is set to cut in as the

## OPERATION OF THE SET

level of water in the storage tank falls. The No. 2 switch controlling the support pump should be set 2" below the No. 1 switch level so that the support pump will start if the level continues to fall.

As the roof storage tank is refilled, the duty pump float switch will have been set to cut out at a pre-determined high level and the No. 2 float switch should be set to cut out the support pump 2" below the No. 1 cut out level. If the ball cock is fitted on the inlet to the tank, the No. 1 switch should be set to cut out 2" below the level where the ball cock closes. The ball cock should be of the equilibrium type.

On systems fitted with a drinking water header, a pipe line switch is fitted and wired to a timer relay in the control panel. When the pipeline switch contacts close the duty pump runs long enough to fill the header tank with fresh water.

The pipework to the drinking water header is arranged so that each time the tank fills the drinking water header is purged with fresh water.

On systems fitted with a drinking water header, a pipe line switch is fitted and wired to a timer relay in the control panel. When the pipeline switch contacts close the duty pump runs long enough to fill the header tank with fresh water.

The pipework to the drinking water header is arranged so that each time the tank fills the drinking water header is purged with fresh water.

In all cases pumps of equal capacity can be alternated via the selector switch.

## CONSTANT RUNNING SETS

These sets are used to provide pressure in mains separated from the municipal supply by break tanks, or to boost the municipal mains supply in low pressure areas.

The constant running system is an alternative to the hydro-pneumatic pressure boosting system and is also known as cascade pumping when more than two pumps are used.

Constant Running sets are usually specified when the system is known to have a minimum continuous demand. They can consist of 2,3,4, or more pumps and the number of pumps used is of course dependent upon the application.

Holden and Brooke have standardised their Constant Running sets as follows:-

- 2 Pump Set:- 1 run and 1 support on standby pump, each duty divided 50-100% of total demand for each pump.
- 3 Pump Set:- 1 run, 1 support and 1 standby pump, duty of each pump 50% of total demand.  
Alternatively:-
- 3 Pump Set:- 1 run and 2 support pumps, duty of each pump 33% of total demand.
- 3 Pump Set:- 1 lead pump and 2 support pumps, lead pump duty 20% of total demand, support pumps 40% of total demand.

## OPERATION OF THE SET

With the control switches set to automatic the lead or run pump will operate continuously providing pressure in the delivery main. As the system demand increases the lead pump output rises and the pressure falls to the point where the first support pump pressure switch is activated. This pump will run to meet the excess demand for as long as this prevails or for a minimum of 4 minutes under the control of a timer relay. The second support pump will also operate in a similar way via its own pressure switch and timer relay. If flow control is being used in place of pressure switches the control remains the same with the timer relay over-riding the flow switch on short term demands. As the system demand decreases the pressure will rise and the support pumps will be switched off.

To avoid overheating of the pumps when the lead pump is running against a zero demand a permanent leak-off has to be provided. This should be a minimum 8mm pipe connected from the delivery manifold to the break tank. This method makes the entire suction side of the system a heat sink for the pump.

## SPECIFICATION

### PUMPS

- Type Starbloc - Horizontal end suction with cast iron body, pedestal and seal casing. Gunmetal impeller, stainless steel shaft with self adjusting mechanical seal.
- Type C/CE - Horizontal end suction single stage with stainless steel impellers, stage chamber, shaft, suction and delivery chambers. Diffuser (C70 & 120) Noryl, C200 stainless steel.
- Type CH - Horizontal end suction multistage with stainless steel impellers, stage

chambers, guide vanes and shaft. Cast iron suction, discharge chamber and motor end shield. Ceramic seal face, carbon seal seat.

- Type CR - Vertical in line multistage pumps with stainless steel impellers, intermediate chambers, guide vanes, sleeve and shaft. Cast iron pump housing and pump head. Tungsten carbide shaft bearing and shaft seal faces. Ceramic intermediate bearing and PTFE neck ring.

### MOTORS

T. E. F. V. Alternatively Drip-proof on types above 11kw.

## BASEPLATE

Fabricated mild steel with integrally mounted control panel.

## MANIFOLDS

Manufactured from UPVC pipe, fittings and valves which are solvent welded together and are suitable for a maximum working pressure of 10bar. Alternatively fabricated from copper tubes to BS2871-71 part 1 table X suitable for a maximum working pressure of 13.8bar. Both types terminate in flanged connections to BS4504 Table 16. Flexible connections can be supplied at extra cost. The pressure gauge, relief valve, pressure switches and bleed pipe connections where supplied will be fitted to the delivery manifold.

## VALVES

Each pump will have isolating valves appropriate to the set material construction on the suction and delivery and non return valves on the delivery. Water board stamped valves will only be fitted when specifically ordered.

## CONTROLS

An individual pressure switch with timer relay for each pump. Prevention of dry running is controlled by either a break tank float switch or a suction manifold low pressure switch to suit application. On Constant Run set the lead pump runs continuously. Should the lead pump fail to meet the demand the No.1 support pump will cut in and support. A remote alarm panel with bell, lamp, and muting buttons are available at extra cost.

Available as an optional extra is control by our MICROSTAR MICROPROCESSOR UNIT. This unit provides faster response to system variations and increased sensitivity. It is also compatible with energy management systems to indicate system malfunction or run and trip to control console. Site reprogramming of the microprocessor is possible. When this unit is used on one of our sets the unit will be mounted in the control panel and the pressure switches and gauges will be replaced by a pressure transducer. See leaflet 1610 for further details.

## CONTROL PANEL

These are pressed steel construction, damp and dust proof IP55 fitted with Test/Off/Auto switches and run/trip lamps for each pump, selector switch, low water and panel energised lamps, lockable door, door interlocked isolator, HRC fuses for motors and control circuit, motor starters and overloads along with terminals and labels. Panels are made suitable for 35°C ambient for temperate zones and 50°C ambient for tropical and sub tropical zones.

## ELECTRICAL WIRING

Wiring to IEE wiring regulations 15th edition.

## VESSELS

These are steel shell water in the bag type and are suitable for both raw and potable water. Larger vessels than those indicated can be supplied if necessary and vessels can be supplied for hot water service expansion. All vessels are precharged at our factory to match the clients specified operating pressure and are suitable for continuous operation up to 70°C and intermittently up to 100°C. Safety valves will be fitted on the pipework adjacent to the vessel.

## ANTI VIBRATION MOUNTINGS

These are of the "neoprene in shear" type and will be bolted direct to the bedplate when ordered. These are an optional extra.

## PUMP START ALTERNATION

This feature can be incorporated into our control panel as an optional extra if required.

## SPECIALS

Customers special requirements will be considered and if practicable will be included at extra cost.

## SCHEMATIC LAYOUT *(Items Shown In Tint Are Supplied With The Set)*

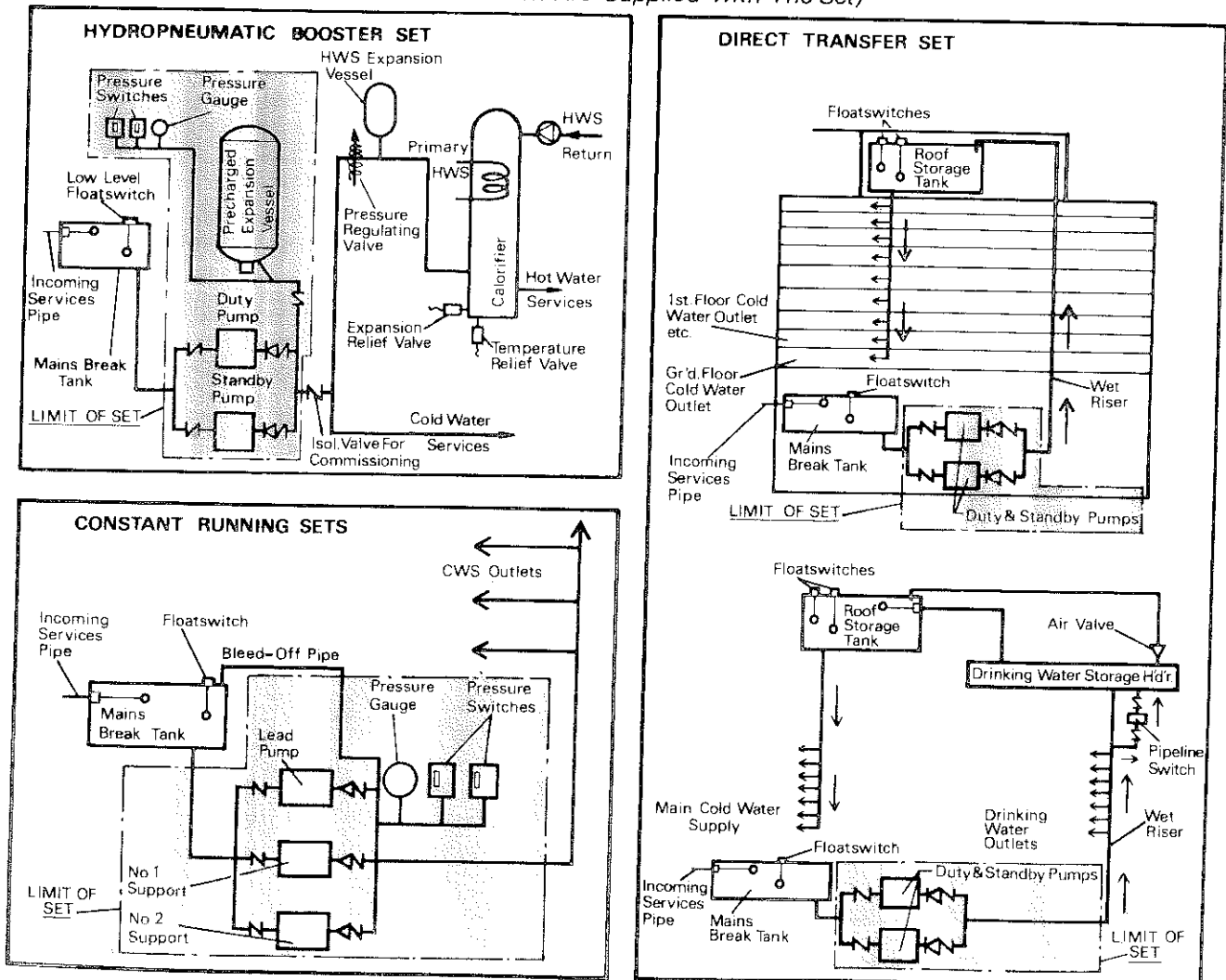

Note: Improvements in general design and modifications in detail will be embodied for the benefit of clients as and when introduced; consequently this specification is subject to alteration, as may be necessary, without notice.

SELECTION CHART STAR RANGE  
END SUCTION PUMPS 2900 RPM  
PERFORMANCE ON WATER SG=1.0

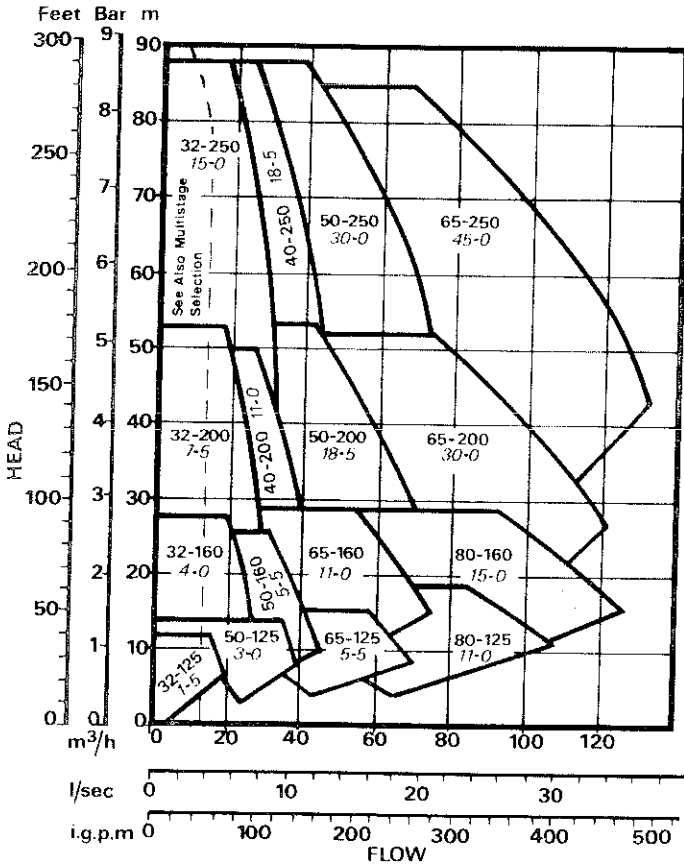

SELECTION CHART  
MULTISTAGE PUMPS 2900 RPM  
PERFORMANCE ON WATER SG=1.0

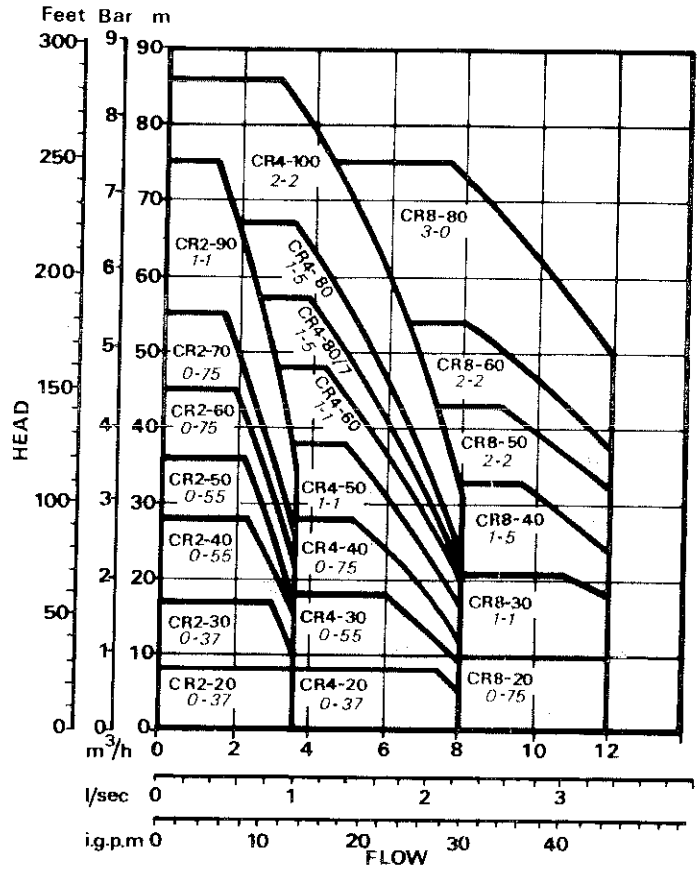

SELECTION CHART  
END SUCTION PUMPS 2900 RPM  
PERFORMANCE ON WATER SG=1.0

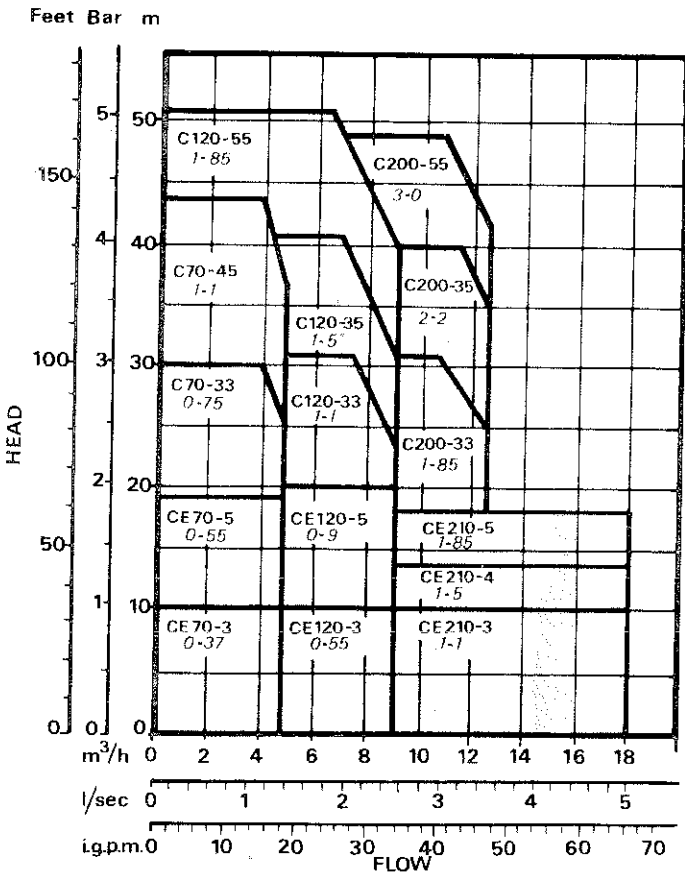

SELECTION CHART  
MULTISTAGE PUMPS 2900 RPM  
PERFORMANCE ON WATER SG=1.0

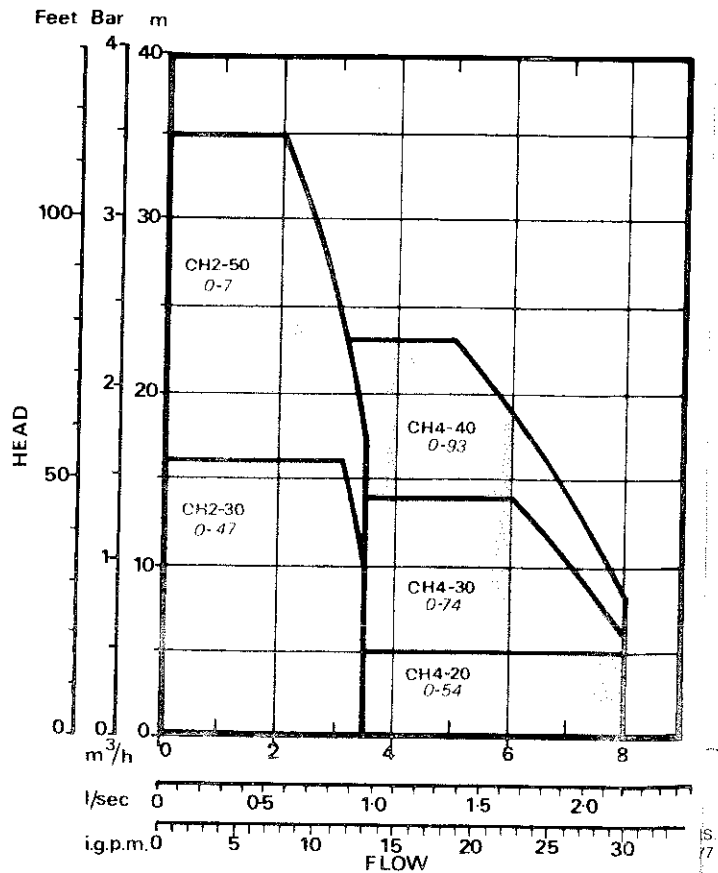

(FIGURES IN ITALICS ARE MOTOR POWERS IN Kw)

**MAXIMUM OVERALL DIMENSIONS**

**SET TYPE**

HYDROPNEUMATIC :  
DIRECT TRANSFER :  
CONSTANT RUN :

**PUMP TYPE**

'CR' MULTISTAGE.

**MAXIMUM W.P.**

10 BAR.

**NOTE:-**

Not all sets are equipped with every item shown.

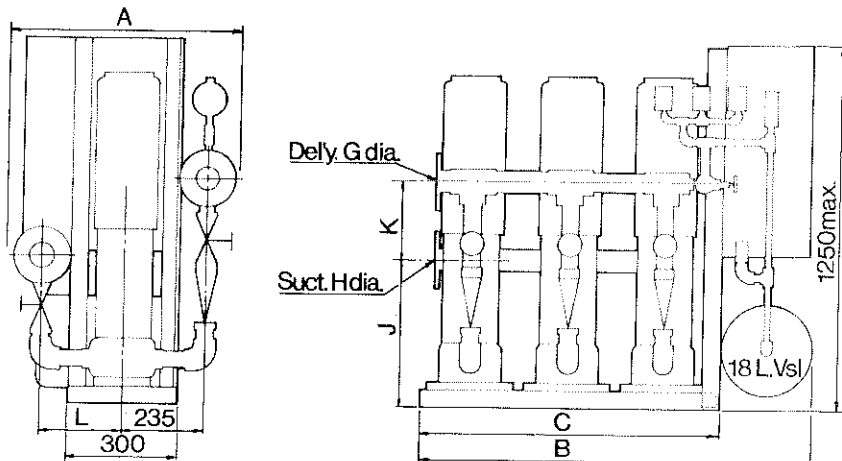

**SET TYPE**

HYDROPNEUMATIC :

**PUMP TYPE**

'CH' MULTISTAGE.

**MAXIMUM W.P.**

6 BAR.

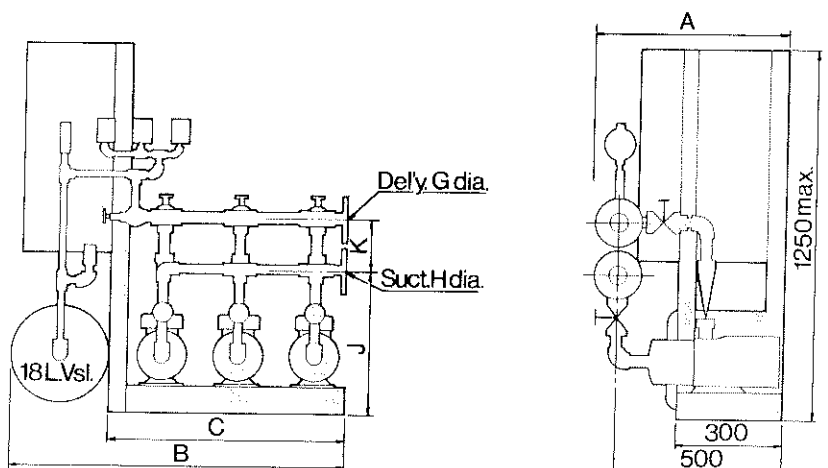

**SET TYPE**

HYDROPNEUMATIC :

**PUMP TYPE**

'C/CE' SINGLE STAGE.

**MAXIMUM W.P.**

8 BAR

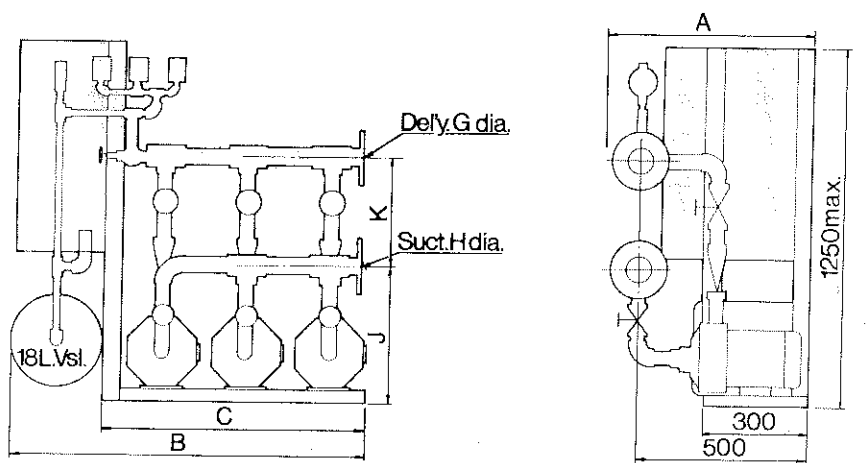

**SET TYPE**

HYDROPNEUMATIC :  
DIRECT TRANSFER :  
CONSTANT RUN :

**PUMP TYPE**

STARBLOC S. STAGE.

**MAXIMUM W.P.**

10 BAR

**NOTE:-**

Not all sets are equipped with every item shown.

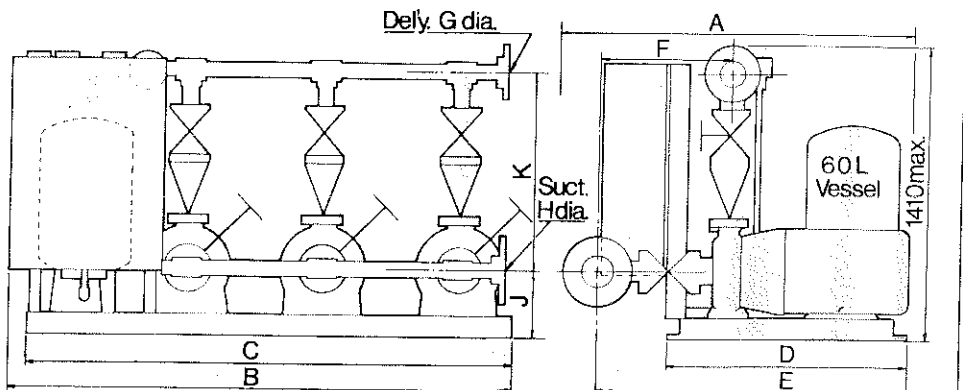

B  
F:  
M  
Y  
w  
11  
1  
ty  
F:  
g:  
w  
V  
E  
c:  
d:  
o:  
C  
A  
of  
st  
R  
to  
re  
al  
A  
M  
s:  
e:  
al  
is  
m  
w  
d:

