



FILE NO.:	6040.121
DATE:	December 21, 2011
SUPERSEDES:	6040.121
DATE:	September 28, 2011

PARTS LIST

SERIES 4030

BASE MOUNTED PUMP

CENTERLINE DISCHARGE
"M" DESIGNATION

1-1/4" IMPELLER BORE -- 1-5/8" MECHANICAL SEAL

NEW DESIGN

NEMA FRAME ASSIGNMENTS

OPEN & TEFC (TEFC FRAMES IN GREY BOX WHERE DIFFERENT THAN OPEN)

FRAME PROGRAM HP	3600 RPM						1800 RPM						1200 RPM			900 RPM		
	"T" FRAMES		"U" FRAMES		ORIGINAL NEMA FRAMES		"T" FRAMES		"U" FRAMES		ORIGINAL NEMA FRAMES		"T" FRAMES	"U" FRAMES	ORIGINAL NEMA FRAMES	"T" FRAMES	"U" FRAMES	ORIGINAL NEMA FRAMES
	1964		1952				1964		1952				1964	1952		1964	1952	
	-		-		-		143T		182		203		145T	184	204	182T	213	225
1 1/2	143T		182		203		145T		184		204		182T	184	224	184T	213	254
2	145T		184		204		145T		184		224		184T	213	225	213T	215	254
3	145T	182T	184		224		182T		213		225		213T	215	254	215T	254U	284
5	182T	184T	213		225		184		215		254		215T	254U	284	254T	256U	324
7 1/2	184T	213T	215		254		213T		254U		284		254T	256U	324	256T	284U	326
10	213T	215T	254U		284		215T		256U		324		256T	284	326	284T	286U	364
15	215T	254T	256U		324		254T		284T		326		284T	234T	364	286T	326U	365
20	254T	256T	284U	286U	326		256T		286U		364		286T	326U	365	324T	364U	404
25	256T	284TS	286U	324U	364S	365S	284T		324U		364	365	324T	364U	404	326T	365U	405
30	284TS	286TS	324S	326S	364S	404S	286T		326U		365	404	326T	365U	405	364T	404U	444
40	286TS	324TS	326S	364US	365S	405S	324T		364U		404	405	364T	404U	444	365T	405U	445
50	324TS	326TS	364US		404S	444S	326T		365US		405S	444S	365T	405U	445	404T	444U	504U
60	326TS	364TS	365US	405US	405S	445S	364TS		404US	405US	444S	445S	404T	444U	504U	405T	445U	505
75	364TS	365TS	404US	444US	444S	504S	365TS		405US	444US	445S	504S	405T	445U	505	444T	-	-
100	365TS	405TS	405US	445US	445S	505S	404TS	405TS	444US	445US	504S	505S	444T	-	-	445T	-	-
125	404TS	444TS	444US		504US		405TS		444TS		445US		505S		445T	-	-	-
150	405TS	445TS	445US		505S		444TS		445TS		-		-		-	-	-	-
200	444TS		-		-		445TS		-		-		-	-	-	-	-	-
250	445TS		-		-		-		-		-		-	-	-	-	-	-

4030 BEARING FRAME UTILIZATION CHART (60 Hz)

MOTOR HP	1150 RPM	-	0.8	-	1.5	-	3	-	7.5	-	-	-	15	-	-	-	25	-	-	-	40	-	-	-	60	-	-	-	100	-	-	-	-	-		
	1750 RPM	0.5	-	1.5	-	2	-	5	-	10	-	-	-	20	-	-	-	30	-	-	-	50	-	-	-	75	-	-	-	125	-	-	-	-	-	
3500 RPM	-	1	2	-	5	-	10	-	20	-	30	-	-	50	-	-	-	75	-	-	-	125	-	-	-	200	-	-	-	-	-	-	-	-	-	
PUMP SIZE	MOTOR FRAME SIZE	5	4	3	2	1	1	2	2	2	2	2	2	2	2	2	2	2	2	2	2	2	2	2	2	2	2	2	2	2	2	2	2	2	2	2
		6	5	4	3	2	1	1	2	2	2	2	2	2	2	2	2	2	2	2	2	2	2	2	2	2	2	2	2	2	2	2	2	2	2	2
1.5x1x6	S	S	S	S	S	S	S	S	-	-	-	-	-	-	-	-	-	-	-	-	-	-	-	-	-	-	-	-	-	-	-	-	-	-		
3x1.5x6	S	S	S	S	S	S	S	S	-	-	-	-	-	-	-	-	-	-	-	-	-	-	-	-	-	-	-	-	-	-	-	-	-	-	-	
3x2x6	S	S	S	S	S	S	S	S	-	-	-	-	-	-	-	-	-	-	-	-	-	-	-	-	-	-	-	-	-	-	-	-	-	-	-	
3x2.5x6	S	S	S	S	S	S	S	S	-	-	-	-	-	-	-	-	-	-	-	-	-	-	-	-	-	-	-	-	-	-	-	-	-	-	-	
4x3x6	S	S	S	S	S	S	S	S	M	M	M	M	-	-	-	-	-	-	-	-	-	-	-	-	-	-	-	-	-	-	-	-	-	-	-	
1.5x1x8	S	S	S	S	S	S	S	S	S	S	S	S	-	-	-	-	-	-	-	-	-	-	-	-	-	-	-	-	-	-	-	-	-	-	-	
3x1.5x8	S	S	S	S	S	S	S	S	S	S	M	M	-	-	-	-	-	-	-	-	-	-	-	-	-	-	-	-	-	-	-	-	-	-	-	
3x2x8	S	S	S	S	S	S	S	S	S	M	M	M	-	-	-	-	-	-	-	-	-	-	-	-	-	-	-	-	-	-	-	-	-	-	-	
3x2.5x8	S	S	S	S	S	S	S	S	M	M	M	M	-	-	M	M	-	-	-	-	-	-	-	-	-	-	-	-	-	-	-	-	-	-	-	
4x3x8	S	S	S	S	S	S	S	S	M	M	M	M	-	-	M	M	-	-	-	-	-	-	-	-	-	-	-	-	-	-	-	-	-	-	-	
5x4x8	-	S	S	S	S	S	S	S	M	M	MHD	MHD	-	-	MHD	MHD	-	-	MHD	MHD	-	-	-	-	-	-	-	-	-	-	-	-	-	-	-	
6x4x8	-	S	S	S	S	S	S	S	M	M	MHD	MHD	-	-	MHD	MHD	-	-	MHD	MHD	-	-	-	-	-	-	-	-	-	-	-	-	-	-	-	
8x8x8	-	-	-	S	S	M	M	M	M	-	-	-	-	-	-	-	-	-	-	-	-	-	-	-	-	-	-	-	-	-	-	-	-	-	-	
2x1x10	S	S	S	S	S	S	S	S	M	M	M	M	-	-	M	M	-	-	-	-	-	-	-	-	-	-	-	-	-	-	-	-	-	-	-	
2x1.5x10	S	S	S	S	S	S	S	S	M	M	M	M	-	-	M	M	-	-	-	-	-	-	-	-	-	-	-	-	-	-	-	-	-	-	-	
3x1.5x10	-	S	S	S	S	S	S	S	M	M	M	M	-	-	M	M	-	-	-	-	-	-	-	-	-	-	-	-	-	-	-	-	-	-	-	
3x2x10	-	S	S	S	S	S	S	S	M	M	M	M	-	-	M	M	-	-	M	M	-	-	-	-	-	-	-	-	-	-	-	-	-	-	-	
3x2.5x10	-	S	S	S	S	S	S	S	M	M	M	M	-	-	M	M	-	-	M	M	-	-	-	-	-	-	-	-	-	-	-	-	-	-	-	
4x3x10	-	-	-	S	S	S	S	S	S	M	M	M	-	-	MHD	MHD	-	-	MHD	MHD	-	-	MHD	MHD	-	-	MHD	MHD	-	-	-	-	-	-	-	
5x4x10	-	-	-	S	S	S	S	S	M	-	-	MHD	MHD	MHD	MHD	-	-	MHD	MHD	-	-	MHD	MHD	-	-	MHD	MHD	-	-	-	-	-	-	-	-	
6x4x10	-	-	-	S	S	S	S	S	M	-	-	MHD	MHD	MHD	MHD	-	-	MHD	MHD	-	-	MHD	MHD	-	-	MHD	MHD	-	-	-	-	-	-	-	-	
6x5x10	-	-	-	S	S	S	S	S	M	-	-	M	M	-	-	M	M	-	-	-	-	-	-	-	-	-	-	-	-	-	-	-	-	-	-	
8x6x10	-	-	-	-	-	M	M	M	M	-	-	M	M	-	-	M	M	-	-	M	M	-	-	-	-	-	-	-	-	-	-	-	-	-	-	
4x3x11.5	-	-	-	S	S	S	S	S	S	-	-	M	M	-	-	-	-	-	-	-	-	-	-	-	-	-	-	-	-	-	-	-	-	-	-	
5x4x11.5	-	-	-	-	-	S	S	S	S	-	-	M	M	-	-	-	-	-	-	-	-	-	-	-	-	-	-	-	-	-	-	-	-	-	-	
6x5x11.5	-	-	-	-	-	S	S	M	M	-	-	M	M	-	-	M	M	-	-	-	-	-	-	-	-	-	-	-	-	-	-	-	-	-	-	
8x6x11.5	-	-	-	-	-	M	M	M	M	-	-	M	M	-	-	M	M	-	-	M	M	-	-	-	-	-	-	-	-	-	-	-	-	-	-	
3x1.5x13	-	-	-	-	-	M	M	M	M	M	M	-	-	MHD	MHD	-	-	MHD	MHD	-	-	MHD	MHD	-	-	MHD	MHD	-	-	-	-	-	-	-	-	
3x2x13	-	-	-	-	-	M	M	M	M	-	-	M	M	MHD	MHD	-	-	MHD	MHD	-	-	MHD	MHD	-	-	MHD	MHD	-	-	-	-	-	-	-	-	
4x3x13	-	-	-	-	-	M	M	M	M	-	-	M	M	-	-	M	M	-	-	-	-	-	-	-	-	-	-	-	-	-	-	-	-	-	-	
4x3x13L	-	-	-	-	-	M	M	M	M	-	-	M	M	-	-	M	M	-	-	-	-	-	-	-	-	-	-	-	-	-	-	-	-	-	-	
6x4x13	-	-	-	-	-	-	-	M	M	-	-	M	M	-	-	M	M	-	-	M	M	-	-	M	M	-	-	-	-	-	-	-	-	-	-	
6x5x13	-	-	-	-	-	-	-	M	M	-	-	M	M	-	-	M	M	-	-	M	M	-	-	M	M	-	-	-	-	-	-	-	-	-	-	
6x5x13H	-	-	-	-	-	-	-	M	M	-	-	M	M	-	-	M	M	-	-	M	M	-	-	M	M	-	-	-	-	-	-	-	-	-	-	
8x6x13	-	-	-	-	-	M	M	M	M	-	-	M	M	-	-	M	M	-	-	M	M	-	-	M	M	-	-	-	-	-	-	-	-	-	-	
10x8x13	-	-	-	-	-	-	-	-	-	-	-	L	L	-	-	L	L	-	-	L	L	-	-	L	L	-	-	L	L	-	-	-	-	-	-	
8x6x15	-	-	-	-	-	-	-	-	-	-	-	L	L	-	-	L	L	-	-	L	L	-	-	L	L	-	-	L	L	-	-	-	-	-	-	
10x8x15	-	-	-	-	-	-	-	-	-	-	-	L	L	-	-	L	L	-	-	L	L	-	-	L	L	-	-	L	L	-	-	-	-	-	-	

LEGEND	DESCRIPTION	IMPELLER BORE	MECHANICAL SEAL SIZE	LUBRICATION	LUBE OPTIONS
S	Small Bearing Frame	7/8" (0.875")	1-1/4" (1.25")	Permanently Greased	Regrease, Oil
M	Medium Bearing Frame	1-1/4" (1.25")	1-5/8" (1.625")	Permanently Greased	Regrease, Oil
MHD*	Medium Heavy-Duty Bearing Frame	1-1/4" (1.25")	1-5/8" (1.625")	Re-Greasable	Oil
L	Large Bearing Frame	1-5/8" (1.625")	2-1/8" (2.125")	Oil	-

* Note: When replacing Old "M" Oil Lubricated Bearing Frames update with New Design MHD Bearing Frame with Double Row Bearings

**SERIES 4030 CENTERLINE DISCHARGE, BASE MOUNTED PUMP
"M" SIZE 1 1/4" IMPELLER BORE -- 1 5/8" MECHANICAL SEAL
EXPLODED VIEW -- PERMANENT GREASE LUBRICATION**

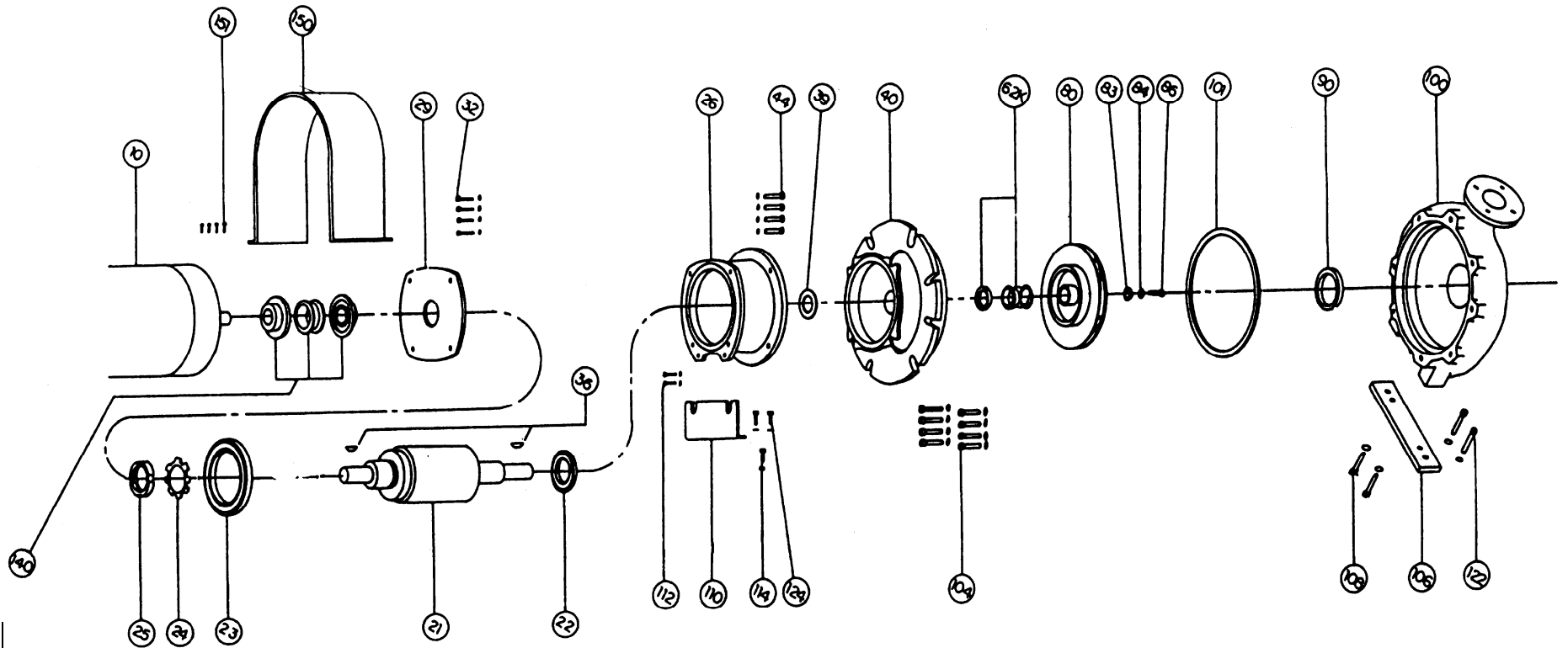

INDEX

ITEM	DESCRIPTION	PAGE	ITEM	DESCRIPTION	PAGE	ITEM	DESCRIPTION	PAGE
21	SHAFT ASSEMBLY	23 & 24	**	BRG. FRAME ASSY.	23 & 24	106	CASING SUPPORT FOOT	30
22	BALL BEARING (INBOARD)	23 & 24	40	ADAPTER	15 TO 20	108	CASING SUPPORT FOOT CAPSCREWS (UPR)	31
23	BALL BEARING (OUTBOARD)	23 & 24	44	ADAPTER CAPSCREW	22	110	BEARING FRAME SUPPORT FOOT	29
24	SPIDER WASHER	23 & 24	62K	MECHANICAL SEAL ASSEMBLY	23 & 24	112	BRG. FRM. SUPPORT FOOT CAPSCREWS (UPR)	34
25	LOCKNUT	23 & 24	80	IMPELLER	10,11 & 12	113	JAM NUT	23 & 24
26	BEARING FRAME	23 & 24	83	IMPELLER WASHER	23 & 24	114	BRG. FRM. SUPPORT FOOT ADJUSTING SCREW	23 & 24
29	BEARING COVER (INBOARD)	23 & 24	86	IMPELLER CAPSCREW	23 & 24	122	CASING SUPPORT FOOT CAPSCREWS (LWR)	32
32	BEARING COVER CAPSCREW	23 & 24	100	CASING	6, 7, 8 & 9	124	BRG. FRM. SUPPORT FOOT CAPSCREWS (LWR)	33
36	IMPELLER/COUPLER KEY	23 & 24	101	CASING GASKET	22	140	COUPLER	35 & 36
39	WATER SLINGER	23 & 24	104	CASING CAPSCREW	13 & 14			

**SERIES 4030 CENTERLINE DISCHARGE, BASE MOUNTED PUMP
 "M" SIZE 1 1/4" IMPELLER BORE -- 1 5/8" MECHANICAL SEAL
 EXPLODED VIEW -- REGREASEABLE BEARINGS**

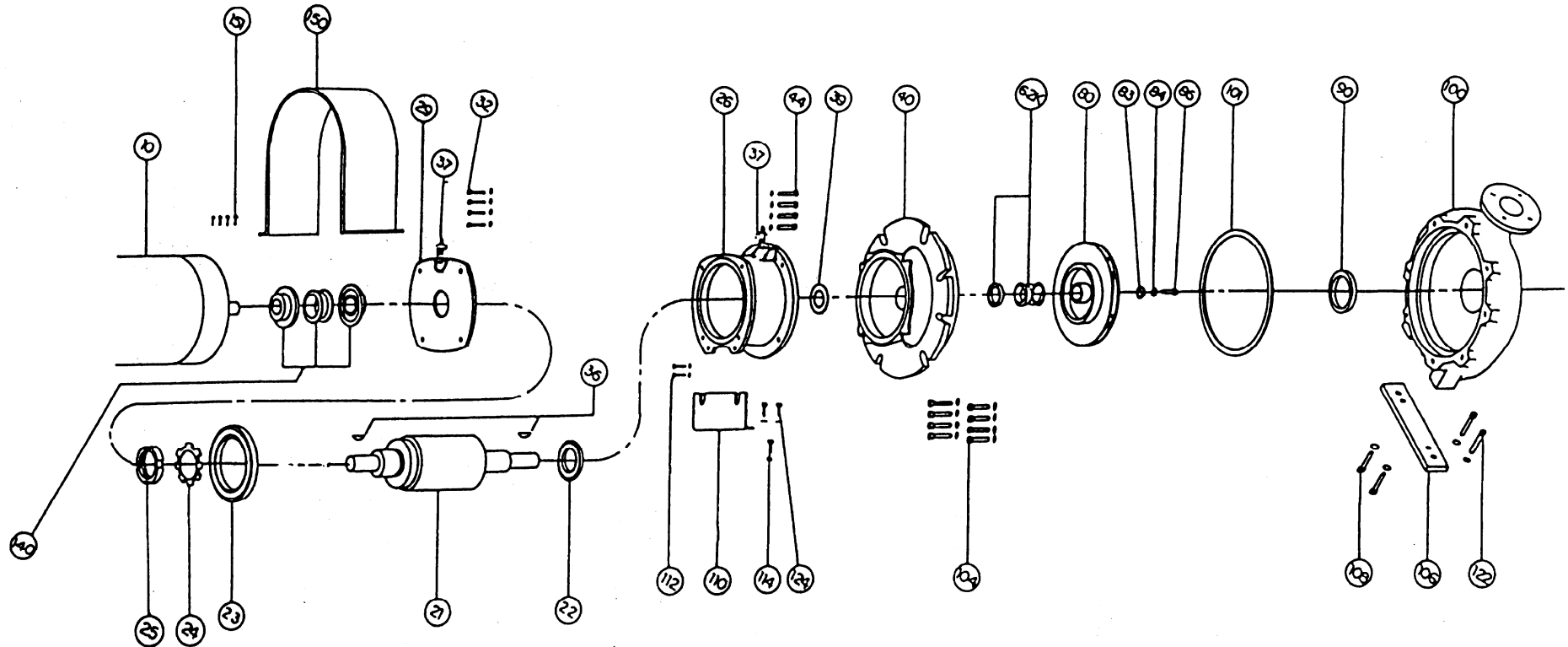

INDEX

ITEM	DESCRIPTION	PAGE	ITEM	DESCRIPTION	PAGE	ITEM	DESCRIPTION	PAGE
**	BRG. FRAME ASSY.	25 & 26	37	GREASE FITTING	25 & 26	104	CASING CAPSCREW	13 & 14
21	SHAFT ASSEMBLY	25 & 26	39	WATER SLINGER	25 & 26	106	CASING SUPPORT FOOT	30
22	BALL BEARING (INBOARD)	25 & 26	40	ADAPTER	15 TO 20	108	CASING SUPPORT FOOT CAPSCREWS (UPR)	31
23	BALL BEARING (OUTBOARD)	25 & 26	44	ADAPTER CAPSCREW	22	110	BEARING FRAME SUPPORT FOOT	29
24	SPIDER WASHER	25 & 26	62	MECHANICAL SEAL ASSEMBLY	25 & 26	112	BRG. FRM. SUPPORT FOOT CAPSCREWS (UPR)	34
25	LOCKNUT	25 & 26	80	IMPELLER	10,11 & 12	113	JAM NUT	25 & 26
26	BEARING FRAME	25 & 26	83	IMPELLER WASHER	25 & 26	114	BRG. FRM. SUPPORT FOOT ADJUSTING SCREW	25 & 26
29	BEARING COVER	25 & 26	86	IMPELLER CAPSCREW	25 & 26	122	CASING SUPPORT FOOT CAPSCREWS (LWR)	32
32	BEARING COVER CAPSCREW	25 & 26	100	CASING	6, 7, 8 & 9	124	BRG. FRM. SUPPORT FOOT CAPSCREWS (LWR)	33
36	IMPELLER/COUPLER KEY	25 & 26	101	CASING GASKET	22	140	COUPLER	35 & 36

**SERIES 4030 CENTERLINE DISCHARGE, BASE MOUNTED PUMP
"M" SIZE 1 1/4" IMPELLER BORE -- 1 5/8" MECHANICAL SEAL
EXPLODED VIEW -- OIL LUBRICATION**

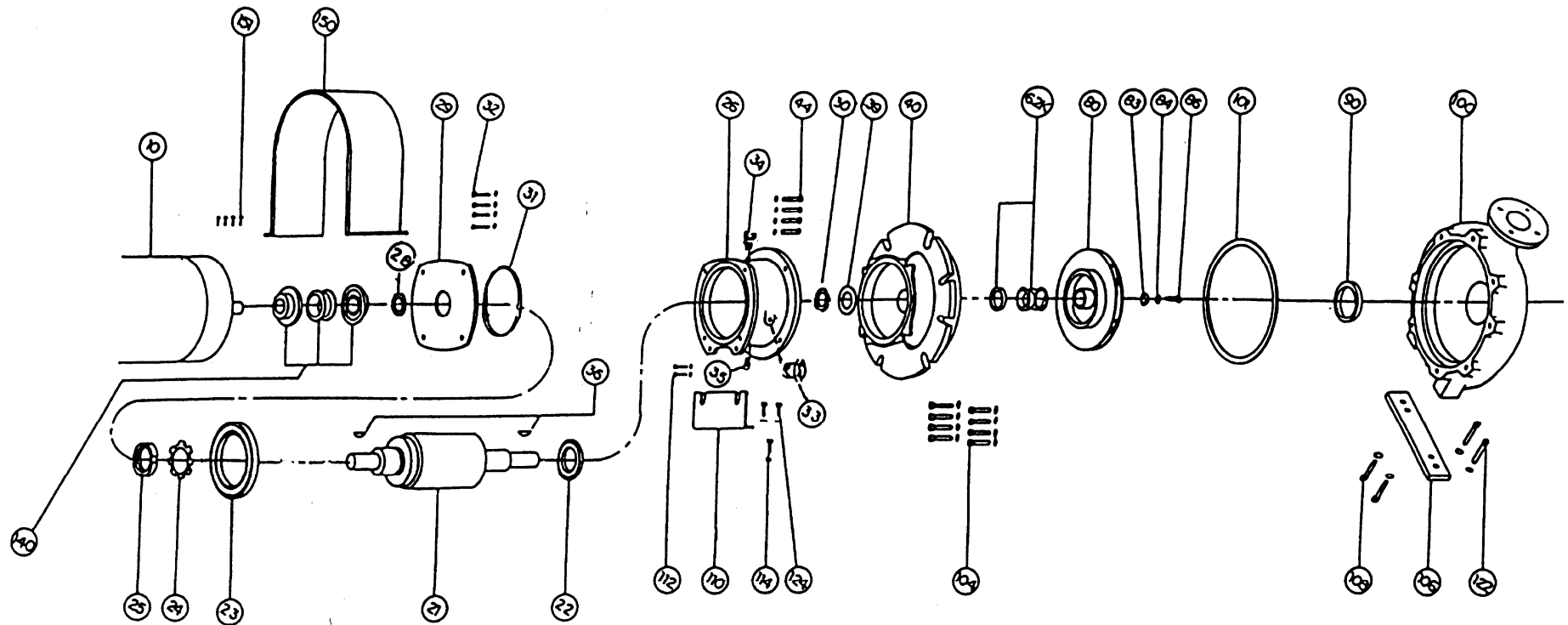

INDEX

ITEM	DESCRIPTION	PAGE	ITEM	DESCRIPTION	PAGE	ITEM	DESCRIPTION	PAGE
**	BRG. FRAME ASSY.	27 & 28	33	OIL VIEW GAUGE	27 & 28	101	CASING GASKET	22
21	SHAFT ASSEMBLY	27 & 28	34	VENT FITTING	27 & 28	104	CASING CAPSCREW	13 & 14
22	BALL BEARING (INBOARD)	27 & 28	35	PIPE PLUG	27 & 28	106	CASING SUPPORT FOOT	30
23	BALL BEARING (OUTBOARD)	27 & 28	36	IMPELLER/COUPLER KEY		108	CASING SUPPORT FOOT CAPSCREWS (UPR)	31
24	SPIDER WASHER	27 & 28	39	WATER SLINGER	27 & 28	110	BEARING FRAME SUPPORT FOOT	29
25	LOCKNUT	27 & 28	40	ADAPTER	15 TO 20	112	BRG. FRM. SUPPORT FOOT CAPSCREWS (UPR)	34
26	BEARING FRAME	27 & 28	44	ADAPTER CAPSCREW	22	113	JAM NUT	27 & 28
28	OIL SEAL (OUTBOARD)	27 & 28	62	MECHANICAL SEAL ASSEMBLY	27 & 28	114	BRG. FRM. SUPPORT FOOT ADJUSTING SCREW	27 & 28
29	BEARING COVER	27 & 28	80	IMPELLER	15 TO 20	122	CASING SUPPORT FOOT CAPSCREWS (LWR)	32
30	OIL SEAL (INBOARD)	27 & 28	83	IMPELLER WASHER	27 & 28	124	BRG. FRM. SUPPORT FOOT CAPSCREWS (LWR)	33
31	"O" RING	27 & 28	86	IMPELLER CAPSCREW	27 & 28	140	COUPLER	35 & 36
32	BEARING COVER CAPSCREW	27 & 28	100	CASING	6, 7, 8 & 9			

**SERIES 4030 CENTERLINE DISCHARGE, BASE MOUNTED PUMP
 "MHD" SIZE 1 1/4" IMPELLER BORE -- 1 5/8" MECHANICAL SEAL
 EXPLODED VIEW -- REGREASEABLE BEARINGS**

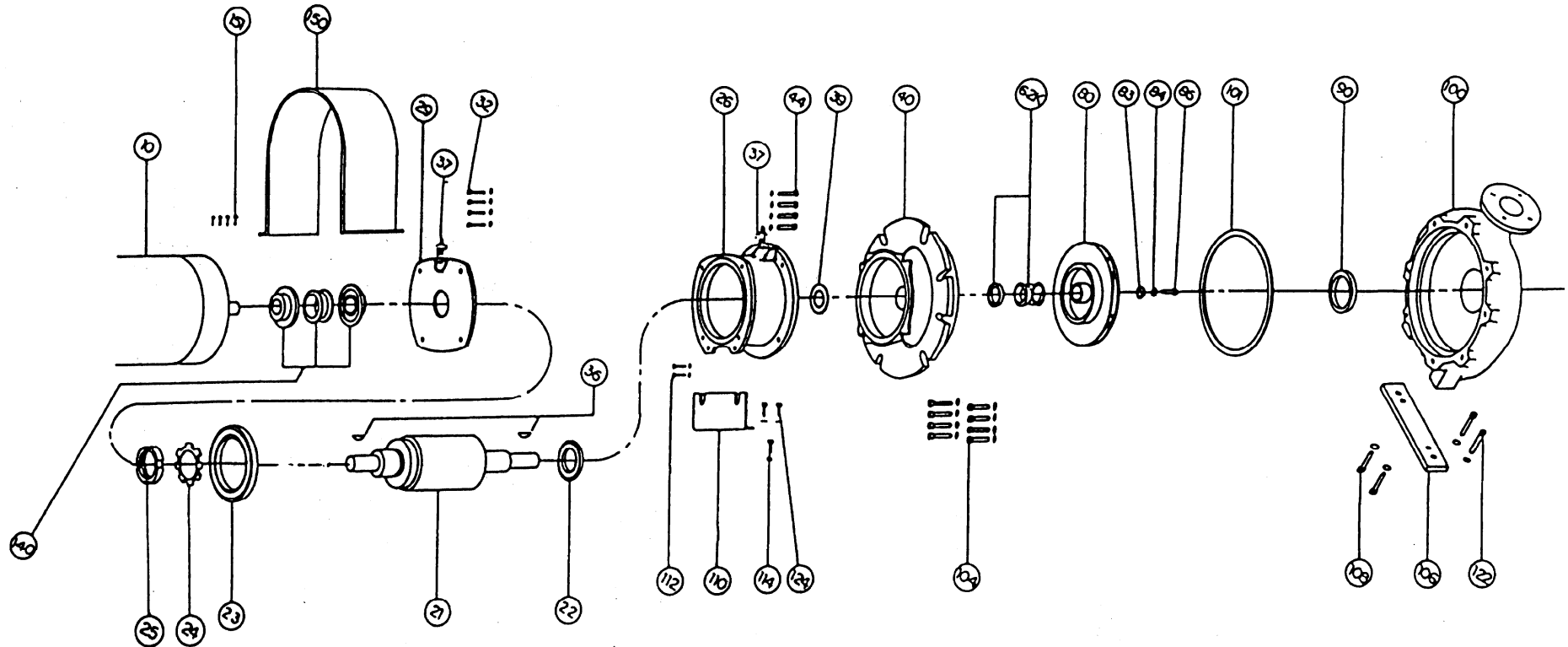

INDEX

ITEM	DESCRIPTION	PAGE	ITEM	DESCRIPTION	PAGE	ITEM	DESCRIPTION	PAGE
**	BRG. FRAME ASSY.	25 & 26	37	GREASE FITTING	25 & 26	104	CASING CAPSCREW	13 & 14
21	SHAFT ASSEMBLY	25 & 26	39	WATER SLINGER	25 & 26	106	CASING SUPPORT FOOT	30
22*	BEARING (INBOARD)	25 & 26	40	ADAPTER	15 TO 20	108	CASING SUPPORT FOOT CAPSCREWS (UPR)	31
23*	BEARING (OUTBOARD)	25 & 26	44	ADAPTER CAPSCREW	22	110	BEARING FRAME SUPPORT FOOT	29
24	SPIDER WASHER	25 & 26	62	MECHANICAL SEAL ASSEMBLY	25 & 26	112	BRG. FRM. SUPPORT FOOT CAPSCREWS (UPR)	34
25	LOCKNUT	25 & 26	80	IMPELLER	10,11 & 12	113	JAM NUT	25 & 26
26	BEARING FRAME	25 & 26	83	IMPELLER WASHER	25 & 26	114	BRG. FRM. SUPPORT FOOT ADJUSTING SCREW	25 & 26
29	BEARING COVER	25 & 26	86	IMPELLER CAPSCREW	25 & 26	122	CASING SUPPORT FOOT CAPSCREWS (LWR)	32
32	BEARING COVER CAPSCREW	25 & 26	100	CASING	6, 7, 8 & 9	124	BRG. FRM. SUPPORT FOOT CAPSCREWS (LWR)	33
36	IMPELLER/COUPLER KEY	25 & 26	101	CASING GASKET	22	140	COUPLER	35 & 36

* NOTE! Bearings are Special---Double Row Angular Contact

**SERIES 4030 CENTERLINE DISCHARGE, BASE MOUNTED PUMP
"MHD" SIZE 1 1/4" IMPELLER BORE -- 1 5/8" MECHANICAL SEAL
EXPLODED VIEW -- OIL LUBRICATION**

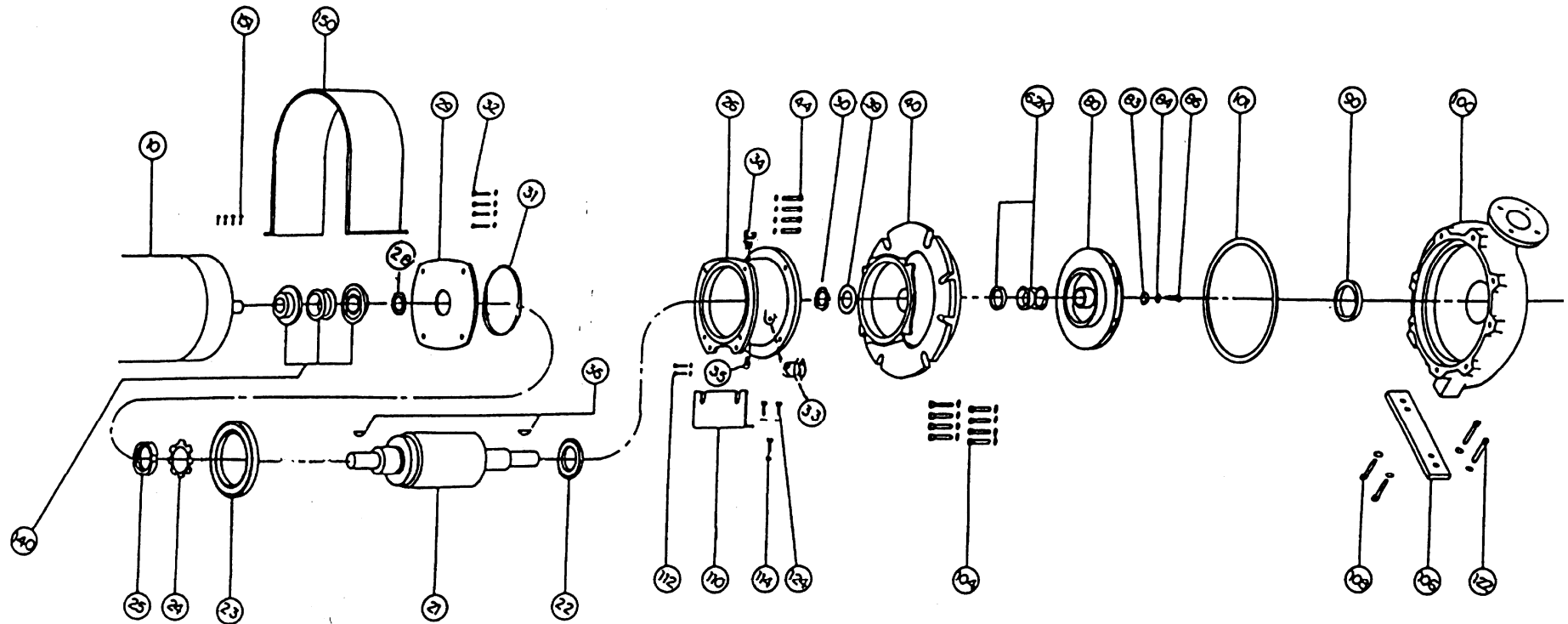

INDEX

ITEM	DESCRIPTION	PAGE	ITEM	DESCRIPTION	PAGE	ITEM	DESCRIPTION	PAGE
**	BRG. FRAME ASSY.	27 & 28	33	OIL VIEW GAUGE	27 & 28	101	CASING GASKET	22
21	SHAFT ASSEMBLY	27 & 28	34	VENT FITTING	27 & 28	104	CASING CAPSCREW	13 & 14
22*	BEARING (INBOARD)	27 & 28	35	PIPE PLUG	27 & 28	106	CASING SUPPORT FOOT	30
23*	BEARING (OUTBOARD)	27 & 28	36	IMPELLER/COUPLER KEY		108	CASING SUPPORT FOOT CAPSCREWS (UPR)	31
24	SPIDER WASHER	27 & 28	39	WATER SLINGER	27 & 28	110	BEARING FRAME SUPPORT FOOT	29
25	LOCKNUT	27 & 28	40	ADAPTER	15 TO 20	112	BRG. FRM. SUPPORT FOOT CAPSCREWS (UPR)	34
26	BEARING FRAME	27 & 28	44	ADAPTER CAPSCREW	22	113	JAM NUT	27 & 28
28	OIL SEAL (OUTBOARD)	27 & 28	62	MECHANICAL SEAL ASSEMBLY	27 & 28	114	BRG. FRM. SUPPORT FOOT ADJUSTING SCREW	27 & 28
29	BEARING COVER	27 & 28	80	IMPELLER	15 TO 20	122	CASING SUPPORT FOOT CAPSCREWS (LWR)	32
30	OIL SEAL (INBOARD)	27 & 28	83	IMPELLER WASHER	27 & 28	124	BRG. FRM. SUPPORT FOOT CAPSCREWS (LWR)	33
31	"O" RING	27 & 28	86	IMPELLER CAPSCREW	27 & 28	140	COUPLER	35 & 36
32	BEARING COVER CAPSCREW	27 & 28	100	CASING	6, 7, 8 & 9			

* NOTE! Bearings are Special---Double Row Angular Contact

4030 PUMP PARTS

CENTERLINE DISCHARGE

"M" SIZE 1 1/4" IMPELLER BORE ----- 1 1/8" SHAFT DIAMETER AT COUPLER

1 5/8" MECHANICAL SEAL

ITEM 100 CASING

PUMP SIZE	PRESSURE RATING	CONST.	PART NUMBER	BAR CODE
4 X 3 X 6	125 LB.	B. F. & A.I.	427292-011	
4 X 3 X 6	250 LB.	D. I.	427293-031	
4 X 3 X 6	125 LB.	A. B.	427292-041	
3 X 1 1/2 X 8	125 LB.	B. F. & A.I.	426599-011	
3 X 1 1/2 X 8	250 LB.	D.I.	426600-031	
3 X 1 1/2 X 8	125 LB.	A. B.	426599-041	
3 X 2 X 8	125 LB.	B. F. & A.I.	426125-011	
3 X 2 X 8	250 LB.	D.I.	426126-031	
3 X 2 X 8	125 LB.	A. B.	426125-041	
3 X 2 1/2 X 8	125 LB.	B. F. & A.I.	427236-011	
3 X 2 1/2 X 8	250 LB.	D.I.	427237-031	
3 X 2 1/2 X 8	125 LB.	A. B.	427236-041	
4 X 3 X 8	125 LB.	B. F. & A.I.	426129-011	
4 X 3 X 8	250 LB.	D.I.	426130-031	
4 X 3 X 8	125 LB.	A. B.	426129-041	
5 X 4 X 8	125 LB.	B. F. & A.I.	426107-011	
5 X 4 X 8	250 LB.	D.I.	426108-031	
5 X 4 X 8	125 LB.	A. B.	426107-041	
6 X 4 X 8	125 LB.	B. F. & A.I.	426624-011	
6 X 4 X 8	250 LB.	D.I.	426625-031	
6 X 4 X 8	125 LB.	A. B.	426624-041	

CASINGS CONTINUED ON PAGE 9

4030 PUMP PARTS

CENTERLINE DISCHARGE

"M" SIZE 1 1/4" IMPELLER BORE ----- 1 1/8" SHAFT DIAMETER AT COUPLER

1 5/8" MECHANICAL SEAL

ITEM 100 CASING				
PUMP SIZE	PRESSURE RATING	CONST.	PART NUMBER	BAR CODE
8 X 8 X 8	125 LB.	B. F. & A.I.	427913-011	
8 X 8 X 8	250 LB.	D. I.	427913-031	
8 X 8 X 8	125 LB.	A. B.	427913-041	
2 X 1 X 10	125 LB.	B. F. & A.I.	426137-011	
2 X 1 X 10	250 LB.	D.I.	426138-031	
2 X 1 X 10	125 LB.	A. B.	426137-041	
2 X 1.5 X 10	125 LB.	B. F. & A.I.	426259-011	
2 X 1.5 X 10	250 LB.	D.I.	426260-031	
2 X 1.5 X 10	125 LB.	A. B.	426259-041	
3 X 1 1/2 X 10	125 LB.	B. F. & A.I.	426139-011	
3 X 1 1/2 X 10	250 LB.	D.I.	426140-031	
3 X 1 1/2 X 10	125 LB.	A. B.	426139-041	
3 X 2 X 10	125 LB.	B. F. & A.I.	426143-011	
3 X 2 X 10	250 LB.	D.I.	426144-031	
3 X 2 X 10	125 LB.	A. B.	426143-041	
3 X 2 1/2 X 10	125 LB.	B. F. & A.I.	427290-011	
3 X 2 1/2 X 10	250 LB.	D.I.	427291-031	
3 X 2 1/2 X 10	125 LB.	A. B.	427290-041	
4 X 3 X 10	125 LB.	B. F. & A.I.	426149-011	
4 X 3 X 10	250 LB.	D.I.	426150-031	
4 X 3 X 10	125 LB.	A. B.	426149-041	

CASINGS CONTINUED ON PAGE 10

4030 PUMP PARTS

CENTERLINE DISCHARGE

"M" SIZE 1 1/4" IMPELLER BORE ----- 1 1/8" SHAFT DIAMETER AT COUPLER

1 5/8" MECHANICAL SEAL

ITEM 100 CASING

PUMP SIZE	PRESSURE RATING	CONST.	PART NUMBER	BAR CODE
5 X 4 X 10	125 LB.	B. F. & A.I.	426111-011	
5 X 4 X 10	250 LB.	D.I.	426112-031	
5 X 4 X 10	125 LB.	A. B.	426111-041	
6 X 4 X 10	125 LB.	B. F. & A.I.	426153-011	
6 X 4 X 10	250 LB.	D.I.	426154-011	
6 X 4 X 10	125 LB.	A. B.	426153-041	
6 X 5 X 10	125 LB.	B. F. & A.I.	427238-011	
6 X 5 X 10	250 LB.	D.I.	427239-041	
6 X 5 X 10	125 LB.	A. B.	427238-041	
8 X 6 X 10	125 LB.	B. F. & A.I.	426605-011	
8 X 6 X 10	250 LB.	D.I.	426606-031	
8 X 6 X 10	125 LB.	A. B.	426605-041	
4 X 3 X 11 1/2	125 LB.	B. F. & A.I.	426147-011	
4 X 3 X 11 1/2	250 LB.	D.I.	426148-031	
4 X 3 X 11 1/2	125 LB.	A. B.	426147-041	
5 X 4 X 11 1/2	125 LB.	B. F. & A.I.	426151-011	
5 X 4 X 11 1/2	250 LB.	D.I.	426152-031	
5 X 4 X 11 1/2	125 LB.	A. B.	426151-041	

CASINGS CONTINUED ON PAGE11

4030 PUMP PARTS

CENTERLINE DISCHARGE

"M" SIZE 1 1/4" IMPELLER BORE ----- 1 1/8" SHAFT DIAMETER AT COUPLER

1 5/8" MECHANICAL SEAL

ITEM 100 CASING

PUMP SIZE	PRESSURE RATING		PART NUMBER	BAR CODE
6 X 5 X 11 1/2	125 LB.	B. F. & A.I.	426155-011	
6 X 5 X 11 1/2	250 LB.	D.I.	426156-031	
6 X 5 X 11 1/2	125 LB.	A. B.	426155-041	
8 X 6 X 11 1/2	125 LB.	B. F. & A.I.	426159-011	
8 X 6 X 11 1/2	250 LB.	D.I.	426160-031	
8 X 6 X 11 1/2	125 LB.	A. B.	426159-041	
3 X 1 1/2 X 13	125 LB.	B. F. & A.I.	426607-011	
3 X 1 1/2 X 13	250 LB.	D.I.	426608-031	
3 X 1 1/2 X 13	125 LB.	A. B.	426607-041	
3 X 2 X 13	125 LB.	B. F. & A.I.	426165-011	
3 X 2 X 13	250 LB.	D.I.	426166-031	
3 X 2 X 13	125 LB.	A. B.	426165-041	
4 X 3 X 13	125 LB.	B. F. & A.I.	426169-011	
4 X 3 X 13	250 LB.	D.I.	426170-031	
4 X 3 X 13	125 LB.	A. B.	426169-041	
6 X 4 X 13	125 LB.	B. F. & A.I.	426173-011	
6 X 4 X 13	250 LB.	D.I.	426174-031	
6 X 4 X 13	125 LB.	A. B.	426173-041	
6 x 5 x 13	125 LB.	B.F. & A.I.	427191-011	
6 x 5 x 13	250 LB.	D.I.	427192-031	
6 x 5 x 13H	125 LB.	B.F. & A.I.	427191-017	
6 x 5 x 13H	250 LB.	D.I.	427192-037	
8 X 6 X 13	125 LB.	B. F. & A.I.	426177-011	
8 X 6 X 13	250 LB.	D.I.	426178-031	
8 X 6 X 13	125 LB.	A. B.	426177-041	

4030 PUMP PARTS

CENTERLINE DISCHARGE

"M" SIZE 1 1/4" IMPELLER BORE ----- 1 1/8" SHAFT DIAMETER AT COUPLER

1 5/8" MECHANICAL SEAL

ITEM 80 IMPELLER*

PUMP SIZE	CONSTRUCTION**	PART NUMBER	BAR CODE
4 X 3 X 6	B. F. & A. B.	427118-041	
4 X 3 X 6	A. I. & D. I.	427118-011	
3 X 1 1/2 X 8	B. F. & A. B.	427122-041	
3 X 1 1/2 X 8	A. I. & D. I.	427122-011	
3 X 2 X 8	B. F. & A. B.	427126-041	
3 X 2 X 8	A. I. & D. I.	427126-011	
3 X 2 1/2 X 8	B. F. & A. B.	427128-041	
3 X 2 1/2 X 8	A. I. & D. I.	427128-031	
4 X 3 X 8	B. F. & A. B.	427130-041	
4 X 3 X 8	A. I. & D. I.	427130-011	
5 X 4 X 8	B. F. & A. B.	427138-041	
5 X 4 X 8	A. I. & D. I.	427138-011	
6 X 4 X 8	B. F. & A. B.	427138-041	
6 X 4 X 8	A. I. & D. I.	427138-011	
8 X 8 X 8	B. F. & A. B.	427918-041	
8 X 8 X 8	A. I. & D. I.	427918-011	
2 X 1 X 10	B. F. & A. B.	427152-041	
2 X 1 X 10	A. I. & D. I.	427152-011	
2 X 1.5 X 10	B. F. & A. B.	426256-041	
2 X 1.5 X 10	A. I. & D. I.	426256-011	

Notes: * Impeller Part Numbers are for unbalanced, full diameter impellers. Always specify the Pump Serial Number. If possible, measure the diameter of the impeller being replaced.

** B. F. Denotes "Bronze Fitted" construction. Parts in contact with the pumped liquid are bronze or copper, except casing and adapter.

A. I. Denotes "All Iron" construction. Parts in contact with the pumped liquid are cast iron or steel, except shaft sleeve & mechanical seal.

IMPELLERS CONTINUED ON PAGE 13

4030 PUMP PARTS

CENTERLINE DISCHARGE

"M" SIZE 1 1/4" IMPELLER BORE ----- 1 1/8" SHAFT DIAMETER AT COUPLER

1 5/8" MECHANICAL SEAL

ITEM 80 IMPELLER*

PUMP SIZE	CONSTRUCTION**	PART NUMBER	BAR CODE
3 X 1 1/2 X 10	B. F. & A. B.	427152-041	
3 X 1 1/2 X 10	A. I. & D. I.	427152-011	
3 X 2 X 10	B. F. & A. B.	427164-041	
3 X 2 X 10	A. I. & D. I.	427164-011	
3 X 2 1/2 X 10	B. F. & A. B.	427124-041	
3 X 2 1/2 X 10	A. I. & D. I.	427124-011	
4 X 3 X 10	B. F. & A. B.	427150-041	
4 X 3 X 10	A. I. & D. I.	427150-011	
5 X 4 X 10	B. F. & A. B.	427154-041	
5 X 4 X 10	A. I. & D. I.	427154-011	
6 X 4 X 10	B. F. & A. B.	427154-041	
6 X 4 X 10	A. I. & D. I.	427154-011	
6 X 5 X 10	B. F. & A. B.	427160-041	
6 X 5 X 10	A. I. & D. I.	427160-011	
8 X 6 X 10	B. F. & A. B.	427157-041	
8 X 6 X 10	A. I. & D. I.	427157-011	

Notes: * Impeller Part Numbers are for unbalanced, full diameter impellers. Always specify the Pump Serial Number. If possible, measure the diameter of the impeller being replaced.
 ** B. F. Denotes "Bronze Fitted" construction. Parts in contact with the pumped liquid are bronze or copper, except casing and adapter.
 A. I. Denotes "All Iron" construction. Parts in contact with the pumped liquid are cast iron or steel, except shaft sleeve & mechanical seal.

IMPELLERS CONTINUED ON PAGE 14

4030 PUMP PARTS

CENTERLINE DISCHARGE

"M" SIZE 1 1/4" IMPELLER BORE ----- 1 1/8" SHAFT DIAMETER AT COUPLER

1 5/8" MECHANICAL SEAL

ITEM 80 IMPELLER*

PUMP SIZE	CONSTRUCTION**	PART NUMBER	BAR CODE
4 X 3 X 11 1/2	B. F. & A. B.	426282-041	
4 X 3 X 11 1/2	A. I. & D. I.	426282-011	
5 X 4 X 11 1/2	B. F. & A. B.	426284-041	
5 X 4 X 11 1/2	A. I. & D. I.	426284-011	
6 X 5 X 11 1/2	B. F. & A. B.	426288-041	
6 X 5 X 11 1/2	A. I. & D. I.	426288-011	
8 X 6 X 11 1/2	B. F. & A. B.	426289-041	
8 X 6 X 11 1/2	A. I. & D. I.	426289-011	
3 X 1 1/2 X 13	B. F. & A. B.	427161-041	
3 X 1 1/2 X 13	A. I. & D. I.	427161-011	
3 X 2 X 13	B. F. & A. B.	427165-041	
3 X 2 X 13	A. I. & D. I.	427165-011	
4 X 3 X 13	B. F. & A. B.	427175-041	
4 X 3 X 13	A. I. & D. I.	427175-011	
6 X 4 X 13	B. F. & A. B.	427173-041	
6 X 4 X 13	A. I. & D. I.	427173-011	
6 x 5 x 13	B.F.	427182-041	
6 x 5 x 13H	B.F.	427177-041	
8 X 6 X 13	B. F. & A. B.	427177-041	
8 X 6 X 13	A. I. & D. I.	427177-011	

Notes: * Impeller Part Numbers are for unbalanced, full diameter impellers. Always specify the Pump Serial Number. If possible, measure the diameter of the impeller being replaced.

** B. F. Denotes "Bronze Fitted" construction. Parts in contact with the pumped liquid are bronze or copper, except casing and adapter.

A. I. Denotes "All Iron" construction. Parts in contact with the pumped liquid are cast iron or steel, except shaft sleeve & mechanical seal.

4030 PUMP PARTS

CENTERLINE DISCHARGE

"M" SIZE 1 1/4" IMPELLER BORE ----- 1 1/8" SHAFT DIAMETER AT COUPLER

1 5/8" MECHANICAL SEAL

ITEM 104 CASING CAPSCREW & WASHER				
PUMP SIZE	NO. REQ'D	SIZE	PART NUMBER	BAR CODE
4 X 3 X 6	8	CAPSCREW 1/2" - 13NC X 1 1/4"LG.	911125-110	
	8	WASHER 1/2" - SAE FLAT	927117-100	
3 X 1 1/2 X 8	8	CAPSCREW 5/8" - 11NC X 1 1/2"LG.	911129-112	
3 X 2 X 8				
3 X 2 1/2 X 8				
4 X 3 X 8				
5 X 4 X 8				
6 X 4 X 8W	8	WASHER 5/8" - SAE FLAT	927121-100	
8 X 8 X 8				
2 X 1 X 10	12	CAPSCREW 5/8" - 11NC X 1 1/2"LG.	911129-112	
2 X 1.5 X 10				
3 X 1 1/2 X 10				
3 X 2 X 10				
3 X 2 1/2 X 10				
4 X 3 X 10				
5 X 4 X 10				
6 X 4 X 10	12	WASHER 5/8 - SAE FLAT	927121-100	
6 X 5 X 10				
8 X 6 X 10				

CASING CAPSCREWS AND WASHERS CONTINUED ON PAGE 16

4030 PUMP PARTS

CENTERLINE DISCHARGE

"M" SIZE 1 1/4" IMPELLER BORE ----- 1 1/8" SHAFT DIAMETER AT COUPLER

1 5/8" MECHANICAL SEAL

ITEM 104 CASING CAPSCREW & WASHER (cont'd)

PUMP SIZE	NO. REQ'D	SIZE	PART NUMBER	BAR CODE
4 X 3 X 11 1/2		CAPSCREW		
5 X 4 X 11 1/2	16	1/2" - 13NC X 1 1/2"LG.	911125-112	
6 X 5 X 11 1/2		WASHER		
8 X 6 X 11 1/2	16	1/2" - SAE FLAT	927117-100	
3 X 1 1/2 X 13		CAPSCREW		
3 X 2 X 13	16	5/8" - 11NC X 1 1/2"LG.	911129-112	
4 X 3 X 13				
6 X 4 X 13		WASHER		
6 x 5 x 13				
6 x 5 x 13H				
8 X 6 X 13	16	5/8" - SAE FLAT	927121-100	

4030 PUMP PARTS

CENTERLINE DISCHARGE

"M" SIZE 1 1/4" IMPELLER BORE ----- 1 1/8" SHAFT DIAMETER AT COUPLER

1 5/8" MECHANICAL SEAL

ITEM 40 ADAPTER				
125 LB. -- BRONZE FITTED & ALL IRON CONSTRUCTION				
PUMP SIZE	FRAME SIZES			BAR CODE
	56 143 - 145T	213 -215T 254 - 256T	284 - 286T/284 - 286TS 324 - 326T/324 - 326TS 364 - 365T/364 - 365TS/404TS	
4 X 3 X 6		426748-011		
3 X 1 1/2 X 8			426751-011	
3 X 2 X 8			426751-011	
3 X 2 1/2 X 8		426751-011	426751-011	
4 X 3 X 8		426751-011	426751-011	
5 X 4 X 8		426751-015	426751-015	
6 X 4 X 8		426751-015	426751-015	
8 X 8 X 8		426751-015		
2 X 1 X 10	426755-011	426755-011	426755-011	
2 X 1.5 X 10	426755-011	426755-011	426755-011	
3 X 1 1/2 X 10	426755-011	426755-011	426755-011	
3 X 2 X 10		426755-011	426755-011	
3 X 2 1/2 X 10		426755-015	426755-015	
4 X 3 X 10			426755-015	
5 X 4 X 10		426755-015	426755-015	
6 X 4 X 10		426755-015	426755-015	
6 X 5 X 10		426755-015	426755-015	

C.I. ADAPTERS CONTINUED ON PAGE 18

4030 PUMP PARTS

CENTERLINE DISCHARGE

"M" SIZE 1 1/4" IMPELLER BORE ----- 1 1/8" SHAFT DIAMETER AT COUPLER

1 5/8" MECHANICAL SEAL

ITEM 40 ADAPTER

125 LB. -- BRONZE FITTED & ALL IRON CONSTRUCTION (cont'd)

PUMP SIZE	FRAME SIZES			BAR CODE
	213 - 213T	254 - 256T	284 - 286T/284 - 286TS 324 - 326T/324 - 326TS 364 - 365T/364 - 365TS/404TS	
8 X 6 X 10		426755-011	426755-011	
4 X 3 X 11 1/2			426742-011	
5 X 4 X 11 1/2	426742-011		426742-011	
6 X 5 X 11 1/2		426742-011	426742-011	
8 X 6 X 11 1/2		426742-011	426742-011	
3 X 1 1/2 X 13	426759-011	426759-011	426759-011	
3 X 2 X 13	426759-011	426759-011	426759-011	
4 X 3 X 13	426759-011	426759-011	426759-011	
6 X 4 X 13		426759-011	426759-011	
6 x 5 x 13		426759-011	426759-011	
6 x 5 x 13H		426759-011	426759-011	
8 X 6 X 13		426759-011	426759-011	

4030 PUMP PARTS

CENTERLINE DISCHARGE

"M" SIZE 1 1/4" IMPELLER BORE ----- 1 1/8" SHAFT DIAMETER AT COUPLER

1 5/8" MECHANICAL SEAL

ITEM 40 ADAPTER				
250 LB. -- DUCTILE IRON CONSTRUCTION				
PUMP SIZE	FRAME SIZES			BAR CODE
	56 143 - 145T	213 -215T 254 - 256T	284 - 286T/284 - 286TS 324 - 326T/324 - 326TS 364 - 365T/364 - 365TS/404TS	
4 X 3 X 6		426748-031		
3 X 1 1/2 X 8			426751-031	
3 X 2 X 8			426751-031	
3 X 2 1/2 X 8		426751-031	426751-031	
4 X 3 X 8		426751-031	426751-031	
5 X 4 X 8		426751-035	426751-035	
6 X 4 X 8		426751-035	426751-035	
8 X 8 X 8		426751-035		
2 X 1 X 10	426755-031	426755-031	426755-031	
2 X 1.5 X 10	426755-031	426755-031	426755-031	
3 X 1 1/2 X 10	426755-031	426755-031	426755-031	
3 X 2 X 10		426755-031	426755-031	
3 X 2 1/2 X 10		426755-035	426755-035	
4 X 3 X 10			426755-035	
5 X 4 X 10		426755-035	426755-035	
6 X 4 X 10			426755-035	
6 X 5 X 10		426755-035	426755-035	

DUCTILE IRON ADAPTERS CONTINUED ON PAGE 20

4030 PUMP PARTS

CENTERLINE DISCHARGE

"M" SIZE 1 1/4" IMPELLER BORE ----- 1 1/8" SHAFT DIAMETER AT COUPLER

1 5/8" MECHANICAL SEAL

ITEM 40 ADAPTER

250 LB. -- DUCTILE IRON CONSTRUCTION (cont'd)

PUMP SIZE	FRAME SIZES			BAR CODE
	213 - 213T	254 - 256T	284 - 286T/284 - 286TS 324 - 326T/324 - 326TS 364 - 365T/364 - 365TS/404TS	
8 X 6 X 10		426755-031	426755-031	
4 X 3 X 11 1/2			426742-031	
5 X 4 X 11 1/2	426755-031		426742-031	
6 X 5 X 11 1/2		426742-031	426742-031	
8 X 6 X 11 1/2		426742-031	426742-031	
3 X 1 1/2 X 13	426759-031	426759-031	426759-031	
3 X 2 X 13	426759-031	426759-031	426759-031	
4 X 3 X 13	426759-031	426759-031	426759-031	
6 X 4 X 13		426759-031	426759-031	
6 x 5 x 13		426759-031	426759-031	
6 x 5 x 13H		426759-031	426759-031	
8 X 6 X 13		426759-031	426759-031	

4030 PUMP PARTS

CENTERLINE DISCHARGE

"M" SIZE 1 1/4" IMPELLER BORE ----- 1 1/8" SHAFT DIAMETER AT COUPLER

1 5/8" MECHANICAL SEAL

ITEM 40 ADAPTER				
125 LB. -- ALL BRONZE CONSTRUCTION				
PUMP SIZE	FRAME SIZES			BAR CODE
	56 143 - 145T	213 - 215T 254 - 256T	284 - 286T/284 - 286TS 324 - 326T/324 - 326TS 364 - 365T/364 - 365TS/404TS	
4 X 3 X 6		426748-041		
3 X 1 1/2 X 8			426751-041	
3 X 2 X 8			426751-041	
3 X 2 1/2 X 8		426751-041	426751-041	
4 X 3 X 8		426751-041	426751-041	
5 X 4 X 8		426751-045	426751-045	
6 X 4 X 8		426751-045	426751-045	
8 X 8 X 8		426751-045		
2 X 1 X 10	426755-041	426755-041	426755-041	
2 X 1.5 X 10	426755-041	426755-041	426755-041	
3 X 1 1/2 X 10	426755-041	426755-041	426755-041	
3 X 2 X 10		426755-041	426755-041	
3 X 2 1/2 X 10		426755-045	426755-045	
4 X 3 X 10			426755-045	
5 X 4 X 10		426755-045	426755-045	
6 X 4 X 10			426755-045	
6 X 5 X 10		426755-045	426755-045	

BRONZE ADAPTERS CONTINUED ON PAGE 22

4030 PUMP PARTS

CENTERLINE DISCHARGE

"M" SIZE 1 1/4" IMPELLER BORE ----- 1 1/8" SHAFT DIAMETER AT COUPLER

1 5/8" MECHANICAL SEAL

ITEM 40 ADAPTER

125 LB. -- ALL BRONZE CONSTRUCTION

PUMP SIZE	FRAME SIZES			BAR CODE
	213 - 213T	254 - 256T	284 - 286T/284 - 286TS 324 - 326T/324 - 326TS 364 - 365T/364 - 365TS/404TS	
8 X 6 X 10		426755-041	426755-041	
4 X 3 X 11 1/2			426755-041	
5 X 4 X 11 1/2	426755-041		426755-041	
6 X 5 X 11 1/2		426742-041	426755-041	
8 X 6 X 11 1/2		426742-041	426742-041	
3 X 1 1/2 X 13	426759-041	426759-041	426759-041	
3 X 2 X 13	426759-041	426759-041	426759-041	
4 X 3 X 13	426759-041	426759-041	426759-041	
6 X 4 X 13		426759-041	426759-041	
6 x 5 x 13		426759-041	426759-041	
6 x 5 x 13H		426759-041	426759-041	
8 X 6 X 13		426759-041	426759-041	

4030 PUMP PARTS

CENTERLINE DISCHARGE

"M" SIZE 1 1/4" IMPELLER BORE ----- 1 1/8" SHAFT DIAMETER AT COUPLER

1 5/8" MECHANICAL SEAL

ITEM 101 CASING GASKET			
PUMP SIZE	DIMENSIONS O.D X I.D. X THICKNESS	PART NUMBER	BAR CODE
4 X 3 X 6	7" X 6 1/4" X 1/16"	426401-002	
3 X 1 1/2 X 8	9" X 8 1/4" X 1/16"	426401-003	
3 X 2 X 8			
3 X 2 1/2 X 8			
4 X 3 X 8			
5 X 4 X 8			
6 X 4 X 8			
8 X 8 X 8			
2 X 1 X 10	10 15/16" X 10 3/16" X 1/16"	426401-004	
2 X 1.5 X 10			
3 X 1 1/2 X 10			
3 X 2 X 10			
3 X 2 1/2 X 10			
4 X 3 X 10			
5 X 4 X 10			
6 X 4 X 10			
6 X 5 X 10			
8 X 5 X 10			
8 X 6 X 10			
4 X 3 X 11 1/2	12 5/16" X 11 9/16" X 1/16"	426401-006	
5 X 4 X 11 1/2			
6 X 5 X 11 1/2			
8 X 6 X 11 1/2			
3 X 1 1/2 X 13	14" X 13 1/4" X 1/16"	426401-005	
3 X 2 X 13			
4 X 3 X 13			
6 X 4 X 13			
6 x 5 x 13			
6 x 5 x 13H			
8 X 6 X 13			

4030 PUMP PARTS

CENTERLINE DISCHARGE

"M" SIZE 1 1/4" IMPELLER BORE ----- 1 1/8" SHAFT DIAMETER AT COUPLER

1 5/8" MECHANICAL SEAL

ITEM 44 BRG. HSG. CAPSCREW & WASHER

PUMP SIZE	NO. REQ'D	SIZE	PART NUMBER	BAR CODE
4 X 3 X 6				
3 X 1 1/2 X 8				
3 X 2 X 8				
3 X 2 1/2 X 8				
4 X 3 X 8				
5 X 4 X 8				
6 X 4 X 8				
8 X 8 X 8				
2 X 1 X 10				
2 X 1.5 X 10				
3 X 1 1/2 X 10	4	CAPSCREW 1/2" - 16NC X 1 1/4" LG.	911125-110	
3 X 2 X 10				
3 X 2 1/2 X 10				
4 X 3 X 10				
5 X 4 X 10				
6 X 4 X 10				
6 X 5 X 10				
8 X 6 X 10				
4 X 3 X 11 1/2				
5 X 4 X 11 1/2	4	WASHER 1/2" FLAT	927117-100	
6 X 5 X 11 1/2				
8 X 6 X 11 1/2				
3 X 1 1/2 X 13				
3 X 2 X 13				
4 X 3 X 13				
6 X 4 X 13				
6 x 5 x 13				
6 x 5 x 13H				
8 X 6 X 13				

4030 PUMP PARTS

CENTERLINE DISCHARGE

"M" SIZE 1 1/4" IMPELLER BORE ----- 1 1/8" SHAFT DIAMETER AT COUPLER

1 5/8" MECHANICAL SEAL

BEARING FRAME ASSY. (STD. FOR B.F.CONSTRUCTION)			
STEEL SHAFT, PERMANENTLY LUBRICATED BEARINGS			
ITEM NUMBER	DESCRIPTION	PART NUMBER	BAR CODE
	BEARING FRAME ASSEMBLY(1)	426771-000	
26	BEARING HOUSING	426765-012	
21	SHAFT & SLEEVE ASSEMBLY	426761-001	
22	INBOARD BEARING	971101-384	
23	OUTBOARD BEARING	971101-704	
24	LOCKWASHER	426364-007	
25	LOCKNUT	426364-006	
29	BEARING CAP	426767-011	
32	BEARING CAPSCREWS 3/8 - 16NC X 1 1/4" LG (4 REQ'D)	911121-110	
36	IMPELLER KEY	428161-714	
36	COUPLER KEY	428161-714	
39	WATER SLINGER	419315-000	
NOTE (1) ITEMS 21 TO 39 INCLUSIVE ARE INCLUDED IN THE BEARING FRAME ASSEMBLY			

COMMON PARTS			
ITEM NUMBER	DESCRIPTION	PART NUMBER BF & AI	BAR CODE
62K	MECHANICAL SEAL KIT	975000-984**	
83	IMPELLER WASHER	425742-003	
86	S/S IMPELLER CAPSCREW	911900-119	
114	SUP. FT. ADJUSTING SCREW 3/8"-16NC X 1" LG. (1 req'd)	911121-108	
113	ADJUSTING SCREW NUT 3/8"-16NC JAM (1req'd)	913521-100	

** For liquids above 200°F/93°C use 9975001-833 (-633 if potable drinking water above 200°F/93°C) For glycols above 30% by weight use 9975001-837 (-838 if above 200°F/93°C)

4030 PUMP PARTS

CENTERLINE DISCHARGE

"M" SIZE 1 1/4" IMPELLER BORE ----- 1 1/8" SHAFT DIAMETER AT COUPLER

1 5/8" MECHANICAL SEAL

BEARING FRAME ASSY. (STD. FOR A.B.CONST.)			
S/S SHAFT, PERMANENTLY LUBRICATED BEARINGS			
ITEM NUMBER	DESCRIPTION	PART NUMBER	BAR CODE
	BEARING FRAME ASSEMBLY(1)	426771-071	
26	BEARING HOUSING	426765-011	
21	SHAFT & SLEEVE ASSEMBLY	426761-071	
22	INBOARD BEARING	971101-384	
23	OUTBOARD BEARING	971101-704	
24	LOCKWASHER	426364-007	
25	LOCKNUT	426364-006	
29	BEARING CAP	426767-011	
32	BEARING CAPSCREWS 3/8 - 16NC X 1 1/4" LG (4 REQ'D)	911121-110	
36	IMPELLER KEY	428161-714	
36	COUPLER KEY	428161-714	
39	WATER SLINGER	419315-000	
NOTE (1) ITEMS 21 TO 39 INCLUSIVE ARE INCLUDED IN THE BEARING FRAME ASSEMBLY			

COMMON PARTS			
ITEM NUMBER	DESCRIPTION	PART NUMBER BF & AI	BAR CODE
62K	MECHANICAL SEAL KIT	975000-984**	
83	IMPELLER WASHER	425742-003	
86	S/S IMPELLER CAPSCREW	911900-119	
114	SUP. FT. ADJUSTING SCREW 3/8"-16NC X 1" LG. (1 req'd)	911121-108	
113	ADJUSTING SCREW NUT 3/8"-16NC JAM (1req'd)	913521-100	

** For liquids above 200°F/93°C use 9975001-833 (-633 if potable drinking water above 200°F/93°C) For glycols above 30% by weight use 9975001-837 (-838 if above 200°F/93°C)

4030 PUMP PARTS

CENTERLINE DISCHARGE

"M" SIZE 1 1/4" IMPELLER BORE ----- 1 1/8" SHAFT DIAMETER AT COUPLER

1 5/8" MECHANICAL SEAL

BEARING FRAME ASSEMBLY

STEEL SHAFT, REGREASEABLE BEARINGS

ITEM NUMBER	DESCRIPTION	PART NUMBER	BAR CODE
	BEARING FRAME ASSEMBLY(1)	426772-000	
26	BEARING HOUSING	426765-012	
21	SHAFT & SLEEVE ASSEMBLY	426761-001	
22	INBOARD BEARING	971101-383	
23	OUTBOARD BEARING	971101-703	
24	LOCKWASHER	426364-007	
25	LOCKNUT	426364-006	
29	BEARING CAP	426767-012	
32	BEARING CAPSCREWS 3/8 - 16NC X 1 1/4" LG (4 REQ'D)	911121-110	
37	GREASE FITTING	425030-011	
36	IMPELLER KEY	428161-714	
36	COUPLER KEY	428161-714	
39	WATER SLINGER	419315-000	

NOTE (1) ITEMS 21 TO 39 INCLUSIVE ARE INCLUDED IN THE BEARING FRAME ASSEMBLY

COMMON PARTS

ITEM NUMBER	DESCRIPTION	PART NUMBER BF & AI	BAR CODE
62K	MECHANICAL SEAL KIT	975000-984**	
83	IMPELLER WASHER	425742-003	
86	S/S IMPELLER CAPSCREW	911900-119	
114	SUP. FT. ADJUSTING SCREW 3/8"-16NC X 1" LG. (1 req'd)	911121-108	
113	ADJUSTING SCREW NUT 3/8"-16NC JAM (1req'd)	913521-100	

** For liquids above 200°F/93°C use 9975001-833 (-633 if potable drinking water above 200°F/93°C) For glycols above 30% by weight use 9975001-837 (-838 if above 200°F/93°C)

4030 PUMP PARTS

CENTERLINE DISCHARGE

"MHD" SIZE 1 1/4" IMPELLER BORE ----- 1 1/8" SHAFT DIAMETER AT COUPLER

1 5/8" MECHANICAL SEAL

BEARING FRAME ASSY. (ALT. FOR A.B. CONSTRUCTION)

S/S SHAFT, REGREASEABLE BEARINGS

ITEM NUMBER	DESCRIPTION	PART NUMBER	BAR CODE
	BEARING FRAME ASSEMBLY(1)	426772-071	
26	BEARING HOUSING	426765-012	
21	SHAFT & SLEEVE ASSEMBLY	426761-071	
22	INBOARD BEARING	971101-383	
23	OUTBOARD BEARING	971101-703	
24	LOCKWASHER	426364-007	
25	LOCKNUT	426364-006	
29	BEARING CAP	426767-012	
	BEARING CAPSCREWS		
32	3/8 - 16NC X 1 1/4" LG (4 REQ'D)	911121-110	
-	GREASE FITTING	425030-011	
36	IMPELLER KEY	428161-714	
36	COUPLER KEY	428161-714	
39	WATER SLINGER	419315-000	

NOTE (1) ITEMS 21 TO 39 INCLUSIVE ARE INCLUDED IN THE BEARING FRAME ASSEMBLY

COMMON PARTS

ITEM NUMBER	DESCRIPTION	PART NUMBER BF & AI	BAR CODE
62K	MECHANICAL SEAL KIT	975000-984**	
83	IMPELLER WASHER	425742-003	
86	S/S IMPELLER CAPSCREW	911900-119	
114	SUP. FT. ADJUSTING SCREW 3/8"-16NC X 1" LG. (1 req'd)	911121-108	
113	ADJUSTING SCREW NUT 3/8"-16NC JAM (1req'd)	913521-100	

** For liquids above 200°F/93°C use 9975001-833 (-633 if potable drinking water above 200°F/93°C) For glycols above 30% by weight use 9975001-837 (-838 if above 200°F/93°C)

4030 PUMP PARTS

CENTERLINE DISCHARGE

"M" SIZE 1 1/4" IMPELLER BORE ----- 1 1/8" SHAFT DIAMETER AT COUPLER

1 5/8" MECHANICAL SEAL

BEARING FRAME ASSEMBLY

STEEL SHAFT, OIL LUBRICATED

ITEM NUMBER	DESCRIPTION	PART NUMBER	BAR CODE
	BEARING FRAME ASSEMBLY(1)	426773-000	
26	BEARING HOUSING	426765-013	
21	SHAFT & SLEEVE ASSEMBLY	426761-001	
22	INBOARD BEARING	971101-917	
23	OUTBOARD BEARING	971101-918	
24	LOCKWASHER	426364-007	
25	LOCKNUT	426364-006	
28	OUTBOARD OIL SEAL	965001-150	
29	BEARING CAP	426767-013	
30	INBOARD OIL SEAL	965001-120	
31	"O" RING	961131-243	
32	BEARING CAPSCREWS 3/8 - 16 X 1 1/4" LG (4 REQ'D)	911121-110	
33	OIL VIEW GAUGE	116904-000	
34	AIR VENT	407444-000	
35	PIPE PLUG 1/8" NPT (1 REQ'D)	937105-200	
36	IMPELLER KEY	428161-714	
36	COUPLER KEY	428161-714	
39	WATER SLINGER	419315-000	

NOTE (1) ITEMS 21 TO 39 INCLUSIVE ARE INCLUDED IN THE BEARING FRAME ASSEMBLY

COMMON PARTS

ITEM NUMBER	DESCRIPTION	PART NUMBER BF & AI	BAR CODE
62K	MECHANICAL SEAL KIT	975000-984**	
83	IMPELLER WASHER	425742-003	
86	S/S IMPELLER CAPSCREW	911900-119	
114	SUP. FT. ADJUSTING SCREW 3/8"-16NC X 1" LG. (1 req'd)	911121-108	
113	ADJUSTING SCREW NUT 3/8"-16NC JAM (1req'd)	913521-100	

** For liquids above 200°F/93°C use 9975001-833 (-633 if potable drinking water above 200°F/93°C) For glycols above 30% by weight use 9975001-837 (-838 if above 200°F/93°C)

4030 PUMP PARTS

CENTERLINE DISCHARGE

"M" SIZE 1 1/4" IMPELLER BORE ----- 1 1/8" SHAFT DIAMETER AT COUPLER

1 5/8" MECHANICAL SEAL

BEARING FRAME ASSY. (ALT. FOR A.B. CONSTRUCTION)

STAINLESS STEEL SHAFT, OIL LUBRICATED

ITEM NUMBER	DESCRIPTION	PART NUMBER	BAR CODE
	BEARING FRAME ASSEMBLY(1)	426773-071	
26	BEARING HOUSING	426765-013	
21	SHAFT & SLEEVE ASSEMBLY	426761-071	
22	INBOARD BEARING	971101-917	
23	OUTBOARD BEARING	971101-918	
24	LOCKWASHER	426364-007	
25	LOCKNUT	426364-006	
28	OUTBOARD OIL SEAL	965001-150	
29	BEARING CAP	426767-013	
30	INBOARD OIL SEAL	965001-120	
31	"O" RING	961131-243	
32	BEARING CAPSCREWS 3/8 - 16NC X 1 1/4" LG (4 REQ'D)	911121-110	
33	OIL VIEW GAUGE	116904-000	
34	AIR VENT	407444-000	
35	PIPE PLUG 1/8" NPT (1 REQ'D)	937105-200	
36	IMPELLER KEY	428161-714	
36	COUPLER KEY	428161-714	
39	WATER SLINGER	419315-000	

NOTE (1) ITEMS 21 TO 39 INCLUSIVE ARE INCLUDED IN THE BEARING FRAME ASSEMBLY

COMMON PARTS

ITEM NUMBER	DESCRIPTION	PART NUMBER BF & AI	BAR CODE
62K	MECHANICAL SEAL KIT	975000-984**	
83	IMPELLER WASHER	425742-003	
86	S/S IMPELLER CAPSCREW	911900-119	
114	SUP. FT. ADJUSTING SCREW 3/8"-16NC X 1" LG. (1 req'd)	911121-108	
113	ADJUSTING SCREW NUT 3/8"-16NC JAM (1req'd)	913521-100	

** For liquids above 200°F/93°C use 9975001-833 (-633 if potable drinking water above 200°F/93°C) For glycols above 30% by weight use 9975001-837 (-838 if above 200°F/93°C)

4030 PUMP PARTS

CENTERLINE DISCHARGE

"MHD" SIZE 1 1/4" IMPELLER BORE ----- 1 1/8" SHAFT DIAMETER AT COUPLER

1 5/8" MECHANICAL SEAL

BEARING FRAME ASSEMBLY

STEEL SHAFT, REGREASEABLE BEARINGS

ITEM NUMBER	DESCRIPTION	PART NUMBER	BAR CODE
	BEARING FRAME ASSEMBLY(1)	427816-000	
26	BEARING HOUSING	426774-012	
21	SHAFT & SLEEVE ASSEMBLY	427833-001	
22	INBOARD BEARING	971101-383	
23	OUTBOARD BEARING (Double Row 50mm Angular Contact)	971115-901	
Not Shown	GREASE SHIELD	971900-003	
24	LOCKWASHER	426364-003	
25	LOCKNUT	426364-004	
29	BEARING CAP	427813-012	
	BEARING CAPSCREWS		
32	3/8 - 16NC X 1 1/4" LG (4 REQ'D)	911121-110	
37	GREASE FITTING	425030-011	
36	IMPELLER KEY	428161-714	
36	COUPLER KEY	428161-714	
39	WATER SLINGER	419315-000	

NOTE (1) ITEMS 21 TO 39 INCLUSIVE ARE INCLUDED IN THE BEARING FRAME ASSEMBLY

COMMON PARTS

ITEM NUMBER	DESCRIPTION	PART NUMBER BF & AI	BAR CODE
62K	MECHANICAL SEAL KIT	975000-984**	
83	IMPELLER WASHER	425742-003	
86	S/S IMPELLER CAPSCREW	911900-119	
114	SUP. FT. ADJUSTING SCREW 3/8"-16NC X 1" LG. (1 req'd)	911121-108	
113	ADJUSTING SCREW NUT 3/8"-16NC JAM (1req'd)	913521-100	

** For liquids above 200°F/93°C use 9975001-833 (-633 if potable drinking water above 200°F/93°C) For glycols above 30% by weight use 9975001-837 (-838 if above 200°F/93°C)

4030 PUMP PARTS

CENTERLINE DISCHARGE

"MHD" SIZE 1 1/4" IMPELLER BORE ----- 1 1/8" SHAFT DIAMETER AT COUPLER

1 5/8" MECHANICAL SEAL

BEARING FRAME ASSEMBLY

S/S SHAFT, REGREASEABLE BEARINGS

ITEM NUMBER	DESCRIPTION	PART NUMBER	BAR CODE
	BEARING FRAME ASSEMBLY(1)	427816-071	
26	BEARING HOUSING	426774-012	
21	SHAFT & SLEEVE ASSEMBLY	427833-071	
22	INBOARD BEARING	971101-383	
23	OUTBOARD BEARING (Double Row 50mm Angular Contact)	971115-901	
Not Shown	GREASE SHIELD	971900-003	
24	LOCKWASHER	426364-003	
25	LOCKNUT	426364-004	
29	BEARING CAP	427813-012	
32	BEARING CAPSCREWS 3/8 - 16NC X 1 1/4" LG (4 REQ'D)	911121-110	
-	GREASE FITTING	425030-011	
36	IMPELLER KEY	428161-714	
36	COUPLER KEY	428161-714	
39	WATER SLINGER	419315-000	

NOTE (1) ITEMS 21 TO 39 INCLUSIVE ARE INCLUDED IN THE BEARING FRAME ASSEMBLY

COMMON PARTS

ITEM NUMBER	DESCRIPTION	PART NUMBER BF & AI	BAR CODE
62K	MECHANICAL SEAL KIT	975000-984**	
83	IMPELLER WASHER	425742-003	
86	S/S IMPELLER CAPSCREW	911900-119	
114	SUP. FT. ADJUSTING SCREW 3/8"-16NC X 1" LG. (1 req'd)	911121-108	
113	ADJUSTING SCREW NUT 3/8"-16NC JAM (1req'd)	913521-100	

** For liquids above 200°F/93°C use 9975001-833 (-633 if potable drinking water above 200°F/93°C) For glycols above 30% by weight use 9975001-837 (-838 if above 200°F/93°C)

4030 PUMP PARTS

CENTERLINE DISCHARGE

"MHD" SIZE 1 1/4" IMPELLER BORE ----- 1 1/8" SHAFT DIAMETER AT COUPLER
1 5/8" MECHANICAL SEAL

BEARING FRAME ASSEMBLY

STEEL SHAFT, OIL LUBRICATED

ITEM NUMBER	DESCRIPTION	PART NUMBER	BAR CODE
	BEARING FRAME ASSEMBLY(1)	427817-000	
26	BEARING HOUSING	426774-013	
21	SHAFT & SLEEVE ASSEMBLY	427833-001	
22	INBOARD BEARING	971101-383	
23	OUTBOARD BEARING (Double Row 50mm Angular Contact)	971115-901	
Not Shown	BEARING SHIELD	971900-003	
24	LOCKWASHER	426364-003	
25	LOCKNUT	426364-004	
28	OUTBOARD OIL SEAL	965001-150	
29	BEARING CAP	427813-013	
30	INBOARD OIL SEAL	965001-120	
31	"O" RING	961131-243	
32	BEARING CAPSCREWS 3/8 - 16 X 1 1/4" LG (4 REQ'D)	911121-110	
33	OIL VIEW GAUGE	116904-000	
34	AIR VENT	407444-000	
35	PIPE PLUG 1/8" NPT (1 REQ'D)	937105-200	
36	IMPELLER KEY	428161-714	
36	COUPLER KEY	428161-714	
39	WATER SLINGER	419315-000	

NOTE (1) ITEMS 21 TO 39 INCLUSIVE ARE INCLUDED IN THE BEARING FRAME ASSEMBLY

COMMON PARTS

ITEM NUMBER	DESCRIPTION	PART NUMBER BF & AI	BAR CODE
62K	MECHANICAL SEAL KIT	975000-984**	
83	IMPELLER WASHER	425742-003	
86	S/S IMPELLER CAPSCREW	911900-119	
114	SUP. FT. ADJUSTING SCREW 3/8"-16NC X 1" LG. (1 req'd)	911121-108	
113	ADJUSTING SCREW NUT 3/8"-16NC JAM (1req'd)	913521-100	

** For liquids above 200°F/93°C use 9975001-833 (-633 if potable drinking water above 200°F/93°C) For glycols above 30% by weight use 9975001-837 (-838 if above 200°F/93°C)

4030 PUMP PARTS

CENTERLINE DISCHARGE

"MHD" SIZE 1 1/4" IMPELLER BORE ----- 1 1/8" SHAFT DIAMETER AT COUPLER

1 5/8" MECHANICAL SEAL

BEARING FRAME ASSEMBLY

STEEL SHAFT, OIL LUBRICATED

ITEM NUMBER	DESCRIPTION	PART NUMBER	BAR CODE
	BEARING FRAME ASSEMBLY(1)	427817-071	
26	BEARING HOUSING	426774-013	
21	SHAFT & SLEEVE ASSEMBLY	427833-071	
22	INBOARD BEARING	971101-383	
23	OUTBOARD BEARING (Double Row 50mm Angular Contact)	971115-901	
Not Shown	BEARING SHIELD	971900-003	
24	LOCKWASHER	426364-003	
25	LOCKNUT	426364-004	
28	OUTBOARD OIL SEAL	965001-150	
29	BEARING CAP	427813-013	
30	INBOARD OIL SEAL	965001-120	
31	"O" RING	961131-243	
32	BEARING CAPSCREWS 3/8 - 16 X 1 1/4" LG (4 REQ'D)	911121-110	
33	OIL VIEW GAUGE	116904-000	
34	AIR VENT	407444-000	
35	PIPE PLUG 1/8" NPT (1 REQ'D)	937105-200	
36	IMPELLER KEY	428161-714	
36	COUPLER KEY	428161-714	
39	WATER SLINGER	419315-000	

NOTE (1) ITEMS 21 TO 39 INCLUSIVE ARE INCLUDED IN THE BEARING FRAME ASSEMBLY

COMMON PARTS

ITEM NUMBER	DESCRIPTION	PART NUMBER BF & AI	BAR CODE
62K	MECHANICAL SEAL KIT	975000-984**	
83	IMPELLER WASHER	425742-003	
86	S/S IMPELLER CAPSCREW	911900-119	
114	SUP. FT. ADJUSTING SCREW 3/8"-16NC X 1" LG. (1 req'd)	911121-108	
113	ADJUSTING SCREW NUT 3/8"-16NC JAM (1req'd)	913521-100	

** For liquids above 200°F/93°C use 9975001-833 (-633 if potable drinking water above 200°F/93°C) For glycols above 30% by weight use 9975001-837 (-838 if above 200°F/93°C)

4030 PUMP PARTS

CENTERLINE DISCHARGE

"M" SIZE 1 1/4" IMPELLER BORE ----- 1 1/8" SHAFT DIAMETER AT COUPLER

1 5/8" MECHANICAL SEAL

ITEM 110 BEARING HOUSING SUPPORT FOOT		
PUMP SIZE	PART NUMBER	BAR CODE
4 X 3 X 6	426998-002	
3 X 1 1/2 X 8 3 X 2 X 8 3 X 2 1/2 X 8 4 X 3 X 8 5 X 4 X 8 6 X 4 X 8 8 X 8 X 8 2 X 1 X 10 2 X 1.5 X 10 3 X 1 1/2 X 10 3 X 2 X 10 3 X 2 1/2 X 10 4 X 3 X 10	426698-001	
5 X 4 X 10 6 X 4 X 10 6 X 5 X 10 8 X 6 X 10 4 X 3 X 11 1/2**	426998-003	
5 X 4 X 11 1/2 6 X 5 X 11 1/2		
8 X 6 X 11 1/2	426998-005	
3 X 1 1/2 X 13 3 X 2 X 13 4 X 3 X 13 6 X 4 X 13	426998-003	
6 x 5 x 13 6 x 5 x 13H	428488-511	
8 X 6 X 13	426998-005	

NOTE **: For Pumps 4 x 3 x 11 1/2, Frame 284T use Part Number 426998-001

4030 PUMP PARTS

CENTERLINE DISCHARGE

"M" SIZE 1 1/4" IMPELLER BORE ----- 1 1/8" SHAFT DIAMETER AT COUPLER

1 5/8" MECHANICAL SEAL

ITEM 106 CASING SUPPORT FOOT

PUMP SIZE	PART NUMBER	BAR CODE
4 X 3 X 6W	NOT REQUIRED	
3 X 1 1/2 X 8	426556-000	
3 X 2 X 8	426555-000	
3 X 2 1/2 X 8	426555-000	
4 X 3 X 8	426555-000	
5 X 4 X 8	426554-000	
6 X 4 X 8W	426554-000	
8 X 8 X 8	426998-001	
2 X 1 X 10	426555-000	
2 X 1.5 X 10	426555-000	
3 X 1 1/2 X 10	NOT REQ'D	
3 X 2 X 10	NOT REQ'D	
3 X 2 1/2 X 10 **	426554-000	
4 X 3 X 10 5 X 4 X 10 6 X 4 X 10 6 X 5 X 10 8 X 6 X 10 4 X 3 X 11 1/2 5 X 4 X 11 1/2 6 X 5 X 11 1/2 8 X 6 X 11 1/2 3 X 1 1/2 X 13 3 X 2 X 13 4 X 3 X 13 6 X 4 X 13 6 x 5 x 13 6 x 5 x 13H 8 X 6 X 13	N O T R E Q U I R E D	

4030 PUMP PARTS

CENTERLINE DISCHARGE

"M" SIZE 1 1/4" IMPELLER BORE ----- 1 1/8" SHAFT DIAMETER AT COUPLER

1 5/8" MECHANICAL SEAL

ITEM 108 CASING SUPPORT FOOT UPPER CAPSCREW				
PUMP SIZE	NO. REQ'D	SIZE	PART NUMBER	BAR CODE
4 X 3 X 6	2	1/2-13NC X 1"	911125-108	
3 X 1 1/2 X 8	2	1/2-13NC X 3"	911125-124	
3 X 2 X 8	2	1/2-13NC x 2"	911125-116	
3 X 2 1/2 X 8	2	1/2-13NC X 1"	911125-108	
4 X 3 X 8	2	1/2-13NC x 2"	911125-116	
5 X 4 X 8	2	1/2-13NC X 1"	911125-108	
6 X 4 X 8	2	1/2-13NC X 1"	911125-108	
8 X 8 X 8	2	1/2-13NC X 1"	911125-108	
2 X 1 X 10	2	1/2-13NC x 2"	911125-116	
2 X 1.5 X 10	2	1/2-13NC x 2"	911125-116	
3 X 1 1/2 X 10*	NOT REQ'D			
3 X 2 X 10	NOT REQ'D			
3 X 2 1/2 X 10	2	1/2-13NC X 1"	911125-108	
4 X 3 X 10	N O T R E Q U I R E D			
5 X 4 X 10				
6 X 4 X 10				
6 X 5 X 10				
8 X 6 X 10				
4 X 3 X 11 1/2				
5 X 4 X 11 1/2				
6 X 5 X 11 1/2				
8 X 6 X 11 1/2				
3 X 1 1/2 X 13				
3 X 2 X 13				
4 X 3 X 13				
6 X 4 X 13				
6 x 5 x 13				
6 x 5 x 13H				
8 X 6 X 13				

4030 PUMP PARTS

CENTERLINE DISCHARGE

"M" SIZE 1 1/4" IMPELLER BORE ----- 1 1/8" SHAFT DIAMETER AT COUPLER

1 5/8" MECHANICAL SEAL

ITEM 122 CASING SUPPORT CAPSCREW AND WASHER				
PUMP SIZE	FRAME SIZE 213 - 286TS	BAR CODE	FRAME SIZE 324 - 404TS	BAR CODE
4 X 3 X 6	WASHER 2 REQUIRED 7/16" FLAT 927116-100		WASHER 2 REQUIRED 1/2" FLAT 927118-100	
3 X 1 1/2 X 8				
3 X 2 X 8				
3 X 2 1/2 X 8				
4 X 3 X 8*				
5 X 4 X 8				
6 X 4 X 8*				
8 X 8 X 8*				
2 X 1 X 10*				
2 X 1.5 X 10*				
3 X 1 1/2 X 10*	CAPSCREW 2 REQUIRED 7/16-11NCX1 1/4" 911123-110		CAPSCREW 2 REQUIRED 1/2-13NCX1 1/4" 911125-110	
3 X 2 X 10*				
3 X 2 1/2 X 10*				
4 X 3 X 10*				
5 X 4 X 10				
6 X 4 X 10				
6 X 5 X 10				
8 X 6 X 10				
4 X 3 X 11 1/2				
5 X 4 X 11 1/2				
6 X 5 X 11 1/2	CAPSCREW 2 REQUIRED 7/16-11NCX1 1/4" 911123-110		CAPSCREW 2 REQUIRED 1/2-13NCX1 1/4" 911125-110	
8 X 6 X 11 1/2				
3 X 1 1/2 X 13				
3 X 2 X 13				
4 X 3 X 13				
6 X 4 X 13				
6 x 5 x 13				
6 x 5 x 13H				
8 X 6 X 13				

*** NOTES**

For Pumps 4 X 3 X 8, 6 X 4 X 8, 2 X 1 X 10 and 3 X 2 X 10 Frame 254-256T

use 2 Capscrews 7/16-11NC X 1" Part Number 911123-108, and 2 Washers 7/16 Flat Part Number 927116-100

For Pumps 4 X 3 X 8, 6 X 4 X 8, 2 X 1 X 10, 3 X 1 1/2 X 10, 3 X 2 X 10 and 4 X 3 X 10 Frame 324-326TS

use 2 capscrews 1/2-13NC X 2" Part Number 911125-116, and 2 Washers 1/2 Flat Part Number 927118-100

For Pumps 6 X 4 X 8, 3 X 2 X 10 and 4 X 3 X 10, Frame 364-365TS

use 2 capscrews 1/2-13NC X 2" Part Number 911125-116, and 2 Washers 1/2 Flat Part Number 927118-100

BAR CODES	
911123-108	
911125-116	
927116-100	
927118-100	

4030 PUMP PARTS

CENTERLINE DISCHARGE

"M" SIZE 1 1/4" IMPELLER BORE ----- 1 1/8" SHAFT DIAMETER AT COUPLER

1 5/8" MECHANICAL SEAL

ITEM 124 SUPPORT FOOT CAPSCREW AND WASHER				
PUMP SIZE	FRAME SIZE 213 - 286TS	BAR CODE	FRAME SIZE 324 - 404TS	BAR CODE
4 X 3 X 6	WASHER 2 REQUIRED 7/16" FLAT 927116-100		WASHER 2 REQUIRED 1/2" FLAT 927118-100	
3 X 1 1/2 X 8				
3 X 2 X 8				
3 X 2 1/2 X 8				
4 X 3 X 8				
5 X 4 X 8				
6 X 4 X 8*				
8 X 8 X 8				
2 X 1 X 10				
2 X 1.5 X 10				
3 X 1 1/2 X 10	CAPSCREW 2 REQUIRED 7/16-11NCX1" 911123-108		CAPSCREW 2 REQUIRED 1/2-13NCX1" 911125-108	
3 X 2 X 10*				
3 X 2 1/2 X 10*				
4 X 3 X 10*				
5 X 4 X 10				
6 X 4 X 10				
6 X 5 X 10				
8 X 6 X 10				
4 X 3 X 11 1/2				
5 X 4 X 11 1/2				
6 X 5 X 11 1/2				
8 X 6 X 11 1/2				
3 X 1 1/2 X 13				
3 X 2 X 13				
4 X 3 X 13				
6 X 4 X 13				
6 x 5 x 13				
6 x 5 x 13H				
8 X 6 X 13				

*** NOTES**

For Pumps 6 X 4 X 8, 3 X 2 X 10 and 4 X 3 X 10 Frame 364-365TS.

use 2 capscrews 1/2-13NC X 1 1/2" Part Number 911125-112, and 2 Washers 1/2 Flat Part Number 927118-100

BAR CODES	
911125-112	
927118-100	

4030 PUMP PARTS

CENTERLINE DISCHARGE

"M" SIZE 1 1/4" IMPELLER BORE ----- 1 1/8" SHAFT DIAMETER AT COUPLER

1 5/8" MECHANICAL SEAL

ITEM 112 SUPPORT FOOT/BRG. FRAME, CAPSCREW AND WASHER		
PUMP SIZE	PART NUMBER	BAR CODE
4 X 3 X 6	WASHER 2 REQUIRED 1/2" FLAT 927117-100	
3 X 1 1/2 X 8		
3 X 2 X 8		
3 X 2 1/2 X 8		
4 X 3 X 8*		
5 X 4 X 8		
6 X 4 X 8*		
8 X 8 X 8		
2 X 1 X 10*		
2 X 1.5 X 10*		
3 X 1 1/2 X 10*		
3 X 2 X 10*		
3 X 2 1/2 X 10*		
4 X 3 X 10*		
5 X 4 X 10		
6 X 4 X 10	CAPSCREW 2 REQUIRED 1/2-13NC X 1" 911125-108	
6 X 5 X 10		
8 X 6 X 10		
4 X 3 X 11 1/2		
5 X 4 X 11 1/2		
6 X 5 X 11 1/2		
8 X 6 X 11 1/2		
3 X 1 1/2 X 13		
3 X 2 X 13		
4 X 3 X 13		
6 X 4 X 13		
6 x 5 x 13		
6 x 5 x 13H		
8 X 6 X 13		

4030 PUMP PARTS

CENTERLINE DISCHARGE

"M" SIZE 1 1/4" IMPELLER BORE ----- 1 1/8" SHAFT DIAMETER AT COUPLER

1 5/8" MECHANICAL SEAL

COUPLER SELECTION TABLE

(WOODS TYPE)

PUMP SHAFT SIZE	MOTOR FRAME SIZE	MOTOR SHAFT SIZE	COUPLER PART NUMBER	WOODS SIZE	BAR CODE
1 1/8"	213T - 215T	1 3/8"	827015 - 000	6J	
1 1/8"	254T - 286TS	1 5/8"	827016 - 000	7J	
1 1/8"	284T - 326TS	1 7/8"	827018 - 000	8S	
1 1/8"	324T - 326T	2 1/8"	827021 - 000	9S	
1 1/8"	364TS - 365TS	1 7/8"	827020 - 000	9S	
1 1/8"	364 - 365T	2 3/8"	827022 - 000	8S	
1 1/8"	404 - 405TS	2 1/8"	827023 - 000	8S	

COUPLER FLANGE PART NUMBERS

COUPLER PART NO.	MOTOR FRAME SIZE	FLANGE BORE	FLANGE PART NUMBER	WOODS SIZE	BAR CODE
827015 - 000	213T - 215T	1 3/8"	975000-836	6J	
		X			
		1 1/8"	975000-834	6J	
827016 - 000	254T - 286TS	1 5/8"	975000-842	7J	
		X			
		1 1/8"	975000-840	7J	
827018 - 000	284T - 326TS	1 7/8"	975000-847	8S	
		X			
		1 1/8"	975000-845	8S	

COUPLERS CONTINUED ON PAGE 36

4030 PUMP PARTS

CENTERLINE DISCHARGE

"M" SIZE 1 1/4" IMPELLER BORE ----- 1 1/8" SHAFT DIAMETER AT COUPLER

1 5/8" MECHANICAL SEAL

COUPLER FLANGE PART NUMBERS (cont'd)

COUPLER PART NO.	MOTOR FRAME SIZE	FLANGE BORE	FLANGE PART NUMBER	WOODS SIZE	BAR CODE
427021 - 000	324T - 326T	1 1/8"	975000-849	9S	
		X			
		2 1/8"	975000-852	9S	
427020 - 000	364TS - 365TS	1 7/8"	975000-851	9S	
		X			
		1 1/8"	975000-849	9S	
427022 - 000	364 - 365T	2 3/8"	975000-844	8S	
		X			
		1 1/8"	975000-845	8S	
427023 - 000	404 - 405TS	2 1/8"	975000-848	8S	
		X			
		1 1/8"	975000-845	8S	

COUPLER INSERT SELECTION TABLE

(WOODS TYPE)

COUPLER INSERT SIZE	MOTOR FRAME SIZE	INSERT NUMBER	PART NUMBER	BAR CODE
6J	213T - 215T	6JE	875000-803	
7J	254T - 286TS	7JE	875000-804	
8S	284T - 326TS	8JE	875000-805	
9S	324T - 326T	9E	875000-807	
9S	364TS - 365TS	9E	875000-807	
8S	364 - 365T	8H	875000-812	
8S	404 - 405TS	8H	875000-812	