

PARTS LIST

SERIES 4300

TC MOTORS ONLY

EQUAL SUCTION & DISCHARGE

VERTICAL IN-LINE
SPLIT COUPLER

"S" DESIGNATION - GROUPS 1 TO 4
7/8" IMPELLER BORE -- 1-1/8" MECHANICAL SEAL

NEW DESIGN

MODEL 4300 - VERTICAL PUMP - SPLIT COUPLING TC MOTORS - SINGLE SUCTION

GROUPS 1 TO 4 SELECTION CHART (S) 1 1/8" Mechanical Seal

PUMP SIZE	SERIES 4300 MOTOR FRAME										
	MOTOR	143	182	FT215	254	284	324	FF300/FF350	404	444	447
	FRAME	145	184	213 215	256	286	326	364 365	405	445	449
GROUP NO.											
1-1/2X1X6	1	TC									
	2		TC								
2X2X6	1	TC									
	2		TC								
	3			TC							
3X3X6	1	TC									
	2		TC								
	3			TC							
4X4X6	1	TC									
	2		TC								
	3			TC							
	4				TC						
1-1/2X1-1/2X8	1	TC									
	2		TC								
	3			TC							
2X2X8	1	TC									
	2		TC								
	3			TC							
	4				TC						
	5										
3X3X8	1	TC									
	2		TC								
	3			TC							
	4				TC						
	5										
	6										
4X4X8	1	TC									
	2		TC								
	3			TC							
	4				TC						
	5										
	6										

CONTINUED ON PAGE 2

MODEL 4300 - VERTICAL PUMP - SPLIT COUPLING (Cont'd)

TC MOTORS - SINGLE SUCTION

GROUPS 1 TO 4 SELECTION CHART (S) 1 1/8" Mechanical Seal

PUMP SIZE	SERIES 4300 MOTOR FRAME										
	MOTOR	143	182	FT215	254	284	324	FF300/FF350	404	444	447
	FRAME	145	184	213 215	256	286	326	364 365	405	445	449
GROUP NO.											
5X5X8	1	TC									
	2		TC								
	3			TC							
	4				TC						
	5										
	6										
6X6X8	2		TC								
	3			TC							
	4				TC						
8X8X8	2		TC								
	3			TC							
	4				TC						
2X2X10	1	TC									
	2		TC								
	3			TC							
	4				TC						
	5										
	6										
3X3X10	1	TC									
	2		TC								
	3			TC							
	4				TC						
	5										
	6										
4X4X10	2		TC								
	3			TC							
	4				TC						
	5										
	6										
	7										
6X6X10	3			TC							
	4				TC						
	5										
	6										
	7										
8X8X10	3			TC							
	4				TC						
	6										
	7										

CONTINUED ON PAGE 3

MODEL 4300 - VERTICAL PUMP - SPLIT COUPLING (Cont'd)

TC MOTORS - SINGLE SUCTION

GROUPS 1 TO 4 SELECTION CHART (S) 1 1/8" Mechanical Seal

PUMP SIZE	SERIES 4300 MOTOR FRAME										
	MOTOR	143	182	FT215	254	284	324	FF300/FF350	404	444	447
	FRAME	145	184	213 215	256	286	326	364 365	405	445	449
GROUP NO.											
4X4X11-1/2	2		TC								
	3			TC							
	4				TC						
	8										
	9										
5X5X11-1/2	2		TC								
	3			TC							
	4				TC						
	8										
	9										
6X6X11-1/2	2		TC								
	3			TC							
	4				TC						
	8										
	9										
8X8X11-1/2	4				TC						
	8										
	9										
	10										

4300 GROUP NO.	1	2	3	4
SEAL SIZE AND PUMP SHAFT DIAMETER	1-1/8	1-1/8	1-1/8	1-1/8
IMPELLER BORE:-	7/8	7/8	7/8	7/8
COUPLING BORE:- MOTOR SHAFT DIA.	7/8	1-1/8	1-3/8	1-5/8
:- PUMP SHAFT DIA.	1-1/8	1-1/8	1-1/8	1-1/8
SHAFT GAP BETWEEN PUMP AND MOTOR	1.375	2.500	2.000	1.375

MODEL 4300 TC

CROSS SECTION VIEW

GROUPS 1,2,3 & 4 - 7/8" IMPELLER BORE - 1 1/8" MECHANICAL SEAL

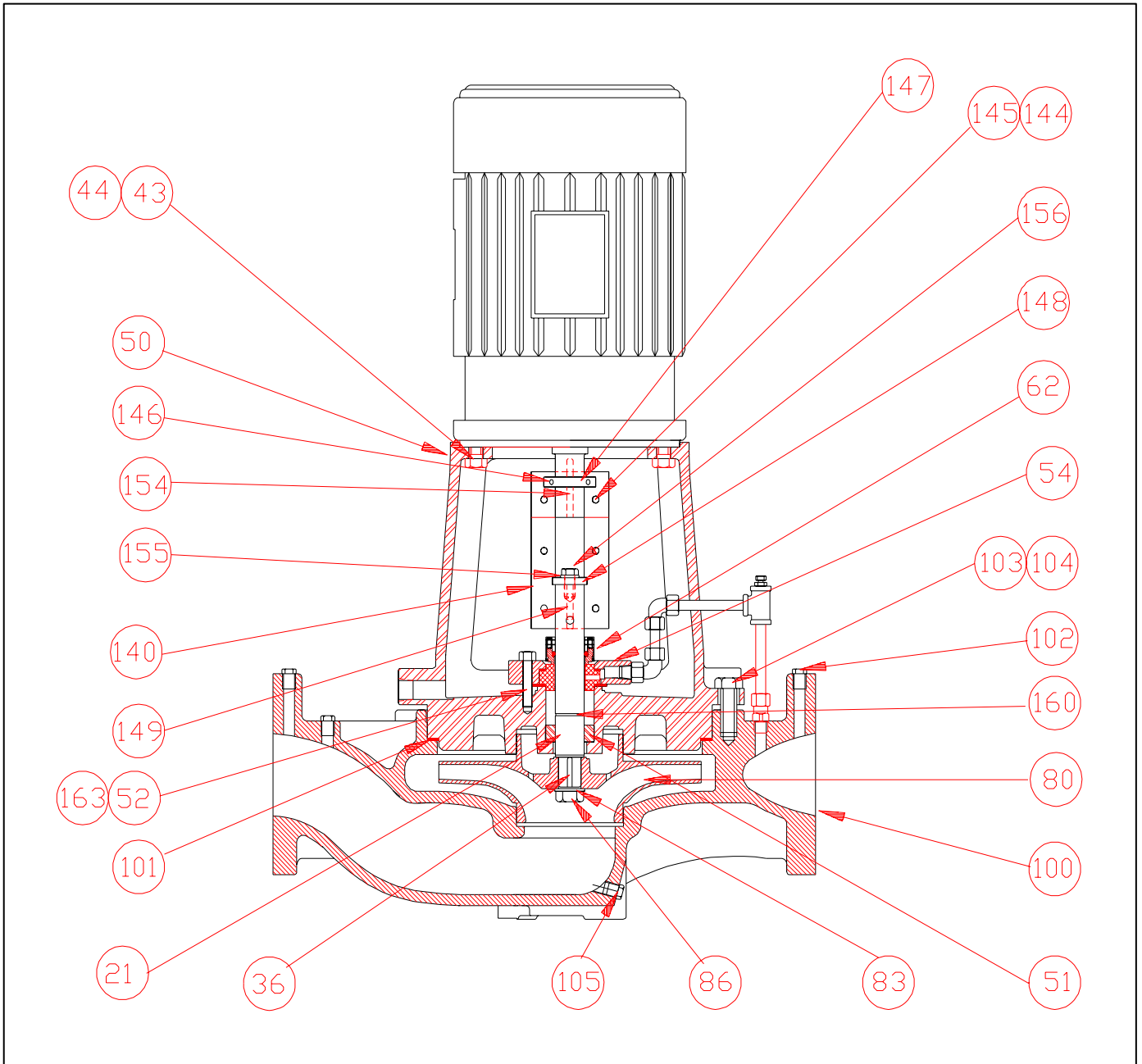

MECHANICAL SEAL ASSEMBLY EXPLODED VIEWS ON PAGE 5A

SEE PAGE 6 FOR PARTS INDEX

MODEL 4300 TC

MECHANICAL SEAL EXPLODED VIEWS

GROUPS 1,2,3 & 4 - 7/8" IMPELLER BORE - 1 1/8" MECHANICAL SEAL

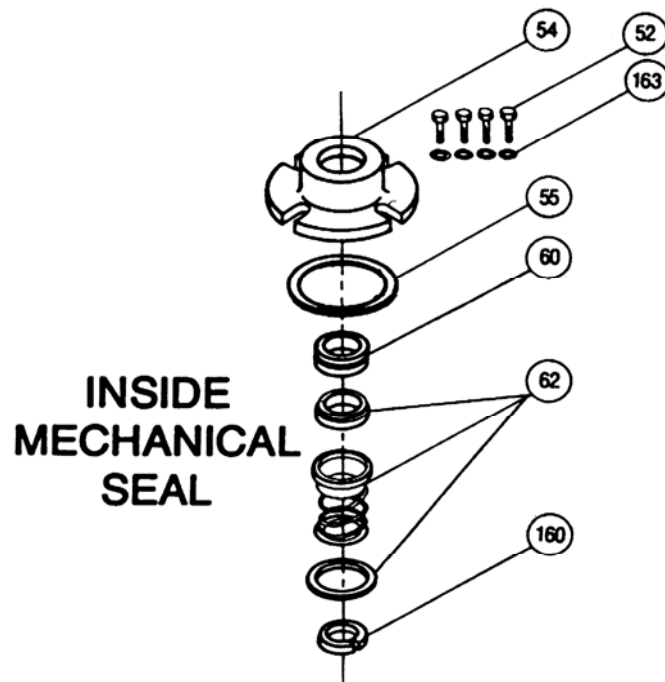
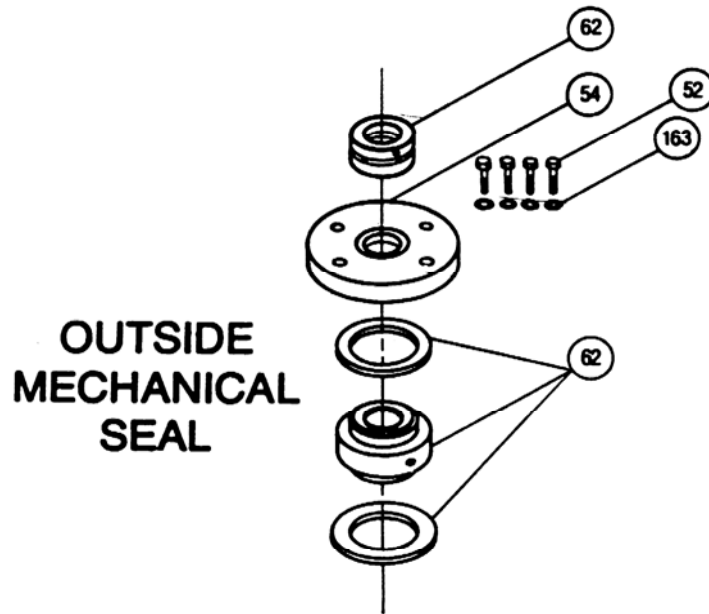

PARTS INDEX

ITEM	DESCRIPTION	PAGE	ITEM	DESCRIPTION	PAGE
21	SHAFT	25	86	IMPELLER CAPSCREW	25
36	IMPELLER KEY	25	90	CASE WEAR RING	15&16
43	LOCKWASHER	21	100	CASING	7,8,&9
44	MOTOR CAPSCREW	21	101	CASING GASKET	12
50	STUFF. BOX/ADAPTER	17,18&19	102	GAUGE PLUG	25
51	SEAL CHAMBER BUSH.	25	103	CASING CAPS. WASHER	13
52	SEAL COV. CAPSCREW	26&27	104	CASING CAPSCREW	13
54	SEAL COVER	26&27	105	CASING DRAIN PLUG	14
55	INSIDE SEAL CVR. GSKT.	27	140	COUPLER	24
58	MALE STRAIGHT CONN.	28	144	COUPLER CAPSCREW	25
59	TUBING	28	145	LOCKWASHER	25
60	INSIDE SEAL SEAT	27	146	COUPLER COLLAR SET SCREW	22
62	OUTSIDE MECH. SEAL JOHN CRANE STD.	26	147	SHAFT COUPLER COLLAR	22
			148	MOTOR COUPLER COLLAR	25
62	OUTSIDE MECH. SEAL JOHN CRANE T.C.	26	149	COUPLER SQUARE KEY (PUMP)	25
			150	COUPLING GUARD (NOT SHOWN)	20
62	OUTSIDE MECH. SEAL DURA STD.	26	151	CPLR. GUARD BOLT (NOT SHOWN)	20
			152	NUT (NOT SHOWN)	20
62	OUTSIDE MECH. SEAL DURA T.C.	26	153	WASHER (NOT SHOWN)	20
			154	COUP. SQUARE KEY (MOTOR)	23
62	INSIDE MECH. SEAL HD. B.F. & A.I. CONST.	27	155	CAPSCREW LOCKWASHER	25
			156	SHAFT CAPSCREW	25
63	1/4"NPT TEE	28	160	INSIDE SEAL RETAINING RING	27
68	AIR VENT	28	163	SEAL COVER CAPS. WASHER	27
80	IMPELLER	10&11	194	MALE 90 DEG. ANGLE CONN.	28
83	IMPELLER WASHER	25			

**VERTICAL IN-LINE - SPLIT COUPLER
MODEL 4300
PUMP PARTS FOR TC MOTORS
EQUAL SUCTION AND DISCHARGE**

GROUPS 1,2,3 & 4 - 7/8" IMPELLER BORE - 1 1/8" MECHANICAL SEAL

ITEM 100 CASING**			
PUMP SIZE	MATERIAL	PART NUMBER	BAR CODE
1 1/2X1 1/2X6	125# C.I.*	427035-011	
1 1/2X1 1/2X6	250# D.I.*	427036-031	
1 1/2X1 1/2X6	125# A.B.*	427035-041	
2X2X6	125# C.I.	427037-011	
2X2X6	250# D.I.	427038-031	
2X2X6	125# A.B.	427037-041	
3X3X6	125# C.I.	427041-011	
3X3X6	250# D.I.	427042-031	
3X3X6	125# A.B.	427041-041	
4X4X6	125# C.I.	427043-011	
4X4X6	250# D.I.	427044-031	
4X4X6	125# A.B.	427043-041	
1 1/2X1 1/2X8	125# C.I.	427045-011	
1 1/2X1 1/2X8	250# D.I.	427046-031	
1 1/2X1 1/2X8	125# A.B.	427045-041	
2X2X8	125# C.I.	427047-011	
2X2X8	250# D.I.	427048-031	
2X2X8	125# A.B.	427047-041	
3X3X8	125# C.I.	427051-011	
3X3X8	250# D.I.	427052-031	
3X3X8	125# A.B.	427051-041	

NOTES:

C.I.* DENOTES CAST IRON

D.I.* DENOTES DUCTILE IRON

A.B. DENOTES ALL BRONZE

** CASING PART NUMBERS ARE FOR CASING ONLY, CASING WEAR RING IS SOLD SEPARATELY.

IF NEW CASING IS REQUIRED, IT MUST BE ORDERED C/W WEAR RING

CASINGS CONTINUED ON PAGE 8

**VERTICAL IN-LINE - SPLIT COUPLER
MODEL 4300
PUMP PARTS FOR TC MOTORS
EQUAL SUCTION AND DISCHARGE**

GROUPS 1,2,3 & 4 - 7/8" IMPELLER BORE - 1 1/8" MECHANICAL SEAL

ITEM 100 CASING** (cont'd)			
PUMP SIZE	MATERIAL	PART NUMBER	BAR CODE
4X4X8	125# C.I.	427053-011	
4X4X8	250# D.I.	427054-031	
4X4X8	125# A.B.	427053-041	
5X5X8	125# C.I.	427024-011	
5X5X8	250# D.I.	427025-031	
5X5X8	125# A.B.	427024-041	
6X6X8	125# C.I.	427055-011	
6X6X8	250# D.I.	427056-031	
6X6X8	125# A.B.	427055-041	
8X8X8	125# C.I.	427915-011	
8X8X8	250# D.I.	427916-031	
8X8X8	125# A.B.	427915-041	
2X2X10	125# C.I.*	427059-011	
2X2X10	250# D.I.*	427060-031	
2X2X10	125# A.B.*	427059-041	
3X3X10	125# C.I.	427061-011	
3X3X10	250# D.I.	427062-031	
3X3X10	125# A.B.	427061-041	
4X4X10	125# C.I.	427063-011	
4X4X10	250# D.I.	427064-031	
4X4X10	125# A.B.	427063-041	

NOTES:

C.I.* DENOTES CAST IRON

D.I.* DENOTES DUCTILE IRON

A.B. DENOTES ALL BRONZE

** CASING PART NUMBERS ARE FOR CASING ONLY, CASING WEAR RING IS SOLD SEPARATELY. IF NEW CASING IS REQUIRED, IT MUST BE ORDERED C/W WEAR RING

CASINGS CONTINUED ON PAGE 9

**VERTICAL IN-LINE - SPLIT COUPLER
MODEL 4300
PUMP PARTS FOR TC MOTORS
EQUAL SUCTION AND DISCHARGE**

GROUPS 1,2,3 & 4 - 7/8" IMPELLER BORE - 1 1/8" MECHANICAL SEAL

ITEM 100 CASING** (cont'd)			
PUMP SIZE	MATERIAL	PART NUMBER	BAR CODE
6X6X10	125# C.I.	427065-011	
6X6X10	250# D.I.	427066-031	
6X6X10	125# B.B.	427065-041	
8X8X10	125# C.I.	427067-011	
8X8X10	250# D.I.	427068-031	
8X8X10	125# A.B.	427067-041	
4X4X11 1/2	125# C.I.	426119-011	
4X4X11 1/2	250# D.I.	426120-031	
4X4X11 1/2	125# A.B.	426119-041	
5X5X11 1/2	125# C.I.	426123-011	
5X5X11 1/2	250# D.I.	426124-031	
5X5X11 1/2	125# A.B.	426123-041	
6X6X11 1/2	125# C.I.	426127-011	
6X6X11 1/2	250# D.I.	426128-031	
6X6X11 1/2	125# A.B.	426127-041	
8X8X11 1/2	125# C.I.	426131-011	
8X8X11 1/2	250# D.I.	426132-031	
8X8X11 1/2	125# A.B.	426131-041	

NOTES:

C.I.* DENOTES CAST IRON

D.I.* DENOTES DUCTILE IRON

**** CASING PART NUMBERS ARE FOR CASING ONLY, CASING WEAR RING IS SOLD SEPARATELY. IF NEW CASING IS REQUIRED, IT MUST BE ORDERED C/W WEAR RING**

**VERTICAL IN-LINE - SPLIT COUPLER
MODEL 4300
PUMP PARTS FOR TC MOTORS
EQUAL SUCTION AND DISCHARGE**

GROUPS 1,2,3 & 4 - 7/8" IMPELLER BORE - 1 1/8" MECHANICAL SEAL

ITEM 80 IMPELLER 7/8" BORE**

PUMP SIZE	MATERIAL	IMP. BORE	MAX. DIA.	PART NUMBER	BAR CODE
1 1/2X1 1/2X6	BRONZE	7/8"	6"	427099-041	
1 1/2X1 1/2X6	CAST IRON	7/8"	6"	427099-011	
2X2X6	BRONZE	7/8"	6"	427109-041	
2X2X6	CAST IRON	7/8"	6"	427109-011	
3X3X6	BRONZE	7/8"	6"	427103-041	
3X3X6	CAST IRON	7/8"	6"	427103-011	
4X4X6	BRONZE	7/8"	6"	427115-041	
4X4X6	CAST IRON	7/8"	6"	427115-011	
1 1/2X1 1/2X8	BRONZE	7/8"	8"	427119-041	
1 1/2X1 1/2X8	CAST IRON	7/8"	8"	427119-011	
2X2X8	BRONZE	7/8"	8"	427121-041	
2X2X8	CAST IRON	7/8"	8"	427121-011	
3X3X8	BRONZE	7/8"	8"	427129-041	
3X3X8	CAST IRON	7/8"	8"	427129-011	
4X4X8	BRONZE	7/8"	8"	427137-041	
4X4X8	CAST IRON	7/8"	8"	427137-011	
5X5X8	BRONZE	7/8"	8"	427131-041	
5X5X8	CAST IRON	7/8"	8"	427131-011	
6X6X8	BRONZE	7/8"	8"	427139-041	
6X6X8	CAST IRON	7/8"	8"	427139-011	
8X8X8	BRONZE	7/8"	8"	427917-041	
8X8X8	CAST IRON	7/8"	8"	427917-011	

NOTES:

** Impeller Part Numbers are for full or maximum diameter Impellers. Always specify Pump Serial Number and where possible, measure and advise the diameter of the Impeller being replaced on these Pumps.

IMPELLERS CONTINUED ON PAGE 11

**VERTICAL IN-LINE - SPLIT COUPLER
MODEL 4300
PUMP PARTS FOR TC MOTORS
EQUAL SUCTION AND DISCHARGE**

GROUPS 1,2,3 & 4 - 7/8" IMPELLER BORE - 1 1/8" MECHANICAL SEAL

ITEM 80 IMPELLER 7/8" BORE (cont'd)**

PUMP SIZE	MATERIAL	IMP. BORE	MAX. DIA.	PART NUMBER	BAR CODE
2x2x10	BRONZE	7/8"	10"	427151-041	
2x2x10	CAST IRON	7/8"	10"	427151-011	
3x3x10	BRONZE	7/8"	10"	427163-041	
3x3x10	CAST IRON	7/8"	10"	427163-011	
4x4x10	BRONZE	7/8"	10"	427149-041	
4x4x10	CAST IRON	7/8"	10"	427149-011	
6x6x10	BRONZE	7/8"	10"	427153-041	
6x6x10	CAST IRON	7/8"	10"	427153-011	
8x8x10	BRONZE	7/8"	10"	427156-041	
8x8x10	CAST IRON	7/8"	10"	427156-011	
4x4x11 1/2	BRONZE	7/8"	11 1/2"	426281-041	
4x4x11 1/2	CAST IRON	7/8"	11 1/2"	426281-011	
5x5x11 1/2	BRONZE	7/8"	11 1/2"	426283-041	
5x5x11 1/2	CAST IRON	7/8"	11 1/2"	426283-011	
6x6x11 1/2	BRONZE	7/8"	11 1/2"	426290-041	
6x6x11 1/2	CAST IRON	7/8"	11 1/2"	426290-011	
8x8x11 1/2	BRONZE	7/8"	11 1/2"	426294-041	
8x8x11 1/2	CAST IRON	7/8"	11 1/2"	426294-011	

NOTES:

** Impeller Part Numbers are for full or maximum diameter Impellers. Always specify Pump Serial Number and where possible, measure and advise the diameter of the Impeller being replaced on these Pumps.

**VERTICAL IN-LINE - SPLIT COUPLER
MODEL 4300
PUMP PARTS FOR TC MOTORS
EQUAL SUCTION AND DISCHARGE**

GROUPS 1,2,3 & 4 - 7/8" IMPELLER BORE - 1 1/8" MECHANICAL SEAL

ITEM 101 CASING GASKET			
PUMP SIZE	CONSTRUCTION	PART NUMBER	BAR CODE
1 1/2X1 1/2X6 2X2X6 3X3X6 4X4X6	ALL	426401-002	
1 1/2X1 1/2X8 2X2X8 3X3X8 4X4X8 5X5X8 6X6X8 8X8X8	ALL	426401-003	
2X2X10 3X3X10 4X4X10 6X6X10 8X8X10	ALL	426401-004	
4X4X11 1/2 5X5X11 1/2 6X6X11 1/2 8X8X11 1/2	ALL	426401-006	

**VERTICAL IN-LINE - SPLIT COUPLER
MODEL 4300
PUMP PARTS FOR TC MOTORS
EQUAL SUCTION AND DISCHARGE**

GROUPS 1,2,3 & 4 - 7/8" IMPELLER BORE - 1 1/8" MECHANICAL SEAL

ITEM 103 CASING CAPSCREW & ITEM 104 NUT				
PUMP SIZE	NUMBER REQUIRED	SIZE	PART NUMBER	BAR CODE
1 1/2X1 1/2X6 2X2X6 3X3X6 4X4X6	12	CAPSCREW 1/2-13NCX1 1/4"	911125-110	
	12	LOCKWASHER 1/2"	927213-100	
1 1/2X1 1/2X8 2X2X8 3X3X8 4X4X8 5X5X8 6X6X8 8X8X8	8	CAPSCREW 5/8-11NCX1 1/2"	911129-112	
	8	WASHER 5/8" FLAT	927121-100	
	12	CAPSCREW 5/8-11NCX1 1/2"	911129-112	
	12	WASHER 5/8" FLAT	927121-100	
4X4X10	12	CAPSCREW 5/8-11NCX1 3/4"	911129-114	
	12	LOCKWASHER 5/8"	927215-100	
6X6X10 8X8X10	12	CAPSCREW 5/8-11NCX1 1/2"	911129-112	
	12	WASHER 5/8" FLAT	927121-100	
4X4X11 1/2 5X5X11 1/2 6X6X11 1/2 8X8X11 1/2	16	CAPSCREW 1/2-13NCX1 1/2"	911125-112	
	16	WASHER 1/2" FLAT	927117-100	

VERTICAL IN-LINE - SPLIT COUPLER MODEL 4300

PUMP PARTS FOR TC MOTORS EQUAL SUCTION AND DISCHARGE

GROUPS 1,2,3 & 4 - 7/8" IMPELLER BORE - 1 1/8" MECHANICAL SEAL

ITEM 105 CASING DRAIN PLUG									
PUMP SIZE	MATERIAL	NO. REQ'D	SIZE	PART NUMBER	BAR CODE				
1 1/2X1 1/2X6 2X2X6 3X3X6 4X4X6	CAD PLATED	1	1/4" NPT	937105-201					
1 1/2X1 1/2X8 2X2X8 3X3X8 4X4X8 6X6X8 8X8X8									
2X2X10 3X3X10 4X4X10 8X8X10									
5X5X8									
6X6X10					CAD PLATED	1	1/2"NPT	937105-203	
4X4X11 1/2 5X5X11 1/2					CAD PLATED	1	1/4" NPT	937105-201	
6X6X11 1/2 8X8X11 1/2					CAD PLATED	1	1/2"NPT	937105-203	

**VERTICAL IN-LINE - SPLIT COUPLER
MODEL 4300
PUMP PARTS FOR TC MOTORS
EQUAL SUCTION AND DISCHARGE**

GROUPS 1,2,3 & 4 - 7/8" IMPELLER BORE - 1 1/8" MECHANICAL SEAL

ITEM 90 CASE WEAR RING			
PUMP SIZE	MATERIAL	PART NUMBER	BAR CODE
1 1/2X1 1/2X6	SAE 660 BRONZE	426413-401	
1 1/2X1 1/2X6	CLASS 30 C.I.	426413-101	
2X2X6	SAE 660 BRONZE	426413-403	
2X2X6	CLASS 30 C.I.	426413-103	
3X3X6	SAE 660 BRONZE	426413-406	
3X3X6	CLASS 30 C.I.	426413-106	
4X4X6	SAE 660 BRONZE	426413-404	
4X4X6	CLASS 30 C.I.	426413-104	
1 1/2X1 1/2X8	SAE 660 BRONZE	426413-402	
1 1/2X1 1/2X8	CLASS 30 C.I.	426413-102	
2X2X8	SAE 660 BRONZE	426413-404	
2X2X8	CLASS 30 C.I.	426413-104	
3X3X8	SAE 660 BRONZE	426413-407	
3X3X8	CLASS 30 C.I.	426413-107	
4X4X8	SAE 660 BRONZE	426413-410	
4X4X8	CLASS 30 C.I.	426413-110	
5X5X8	SAE 660 BRONZE	426413-413	
5X5X8	CLASS 30 C.I.	426413-113	
6X6X8	SAE 660 BRONZE	426413-404	
6X6X8	CLASS 30 C.I.	426413-104	
8X8X8	SAE 660 BRONZE		
8X8X8	CLASS 30 C.I.		

WEAR RINGS CONTINUED ON PAGE 16

**VERTICAL IN-LINE - SPLIT COUPLER
MODEL 4300
PUMP PARTS FOR TC MOTORS
EQUAL SUCTION AND DISCHARGE**

GROUPS 1,2,3 & 4 - 7/8" IMPELLER BORE - 1 1/8" MECHANICAL SEAL

ITEM 90 CASE WEAR RING (cont'd)

PUMP SIZE	MATERIAL	PART NUMBER	BAR CODE
2x2x10	SAE 660 BRONZE	426413-404	
2x2x10	CLASS 30 C.I.	426413-104	
3x3x10	SAE 660 BRONZE	426413-404	
3x3x10	CLASS 30 C.I.	426413-104	
4x4x10	SAE 660 BRONZE	426413-408	
4x4x10	CLASS 30 C.I.	426413-108	
6x6x10	SAE 660 BRONZE	426413-412	
6x6x10	CLASS 30 C.I.	426413-112	
8x8x10	SAE 660 BRONZE	426413-414	
8x8x10	CLASS 30 C.I.	426413-114	
4x4x11 1/2	SAE 660 BRONZE	426412-405	
4x4x11 1/2	CLASS 30 C.I.	426412-105	
5x5x11 1/2	SAE 660 BRONZE	426412-411	
5x5x11 1/2	CLASS 30 C.I.	426413-111	
6x6x11 1/2	SAE 660 BRONZE	426412-420	
6x6x11 1/2	CLASS 30 C.I.	426412-120	
8x8x11 1/2	SAE 660 BRONZE	426412-421	
8x8x11 1/2	CLASS 30 C.I.	426412-121	

**VERTICAL IN-LINE - SPLIT COUPLER
MODEL 4300
PUMP PARTS FOR TC MOTORS
EQUAL SUCTION AND DISCHARGE**

GROUPS 1,2,3 & 4 - 7/8" IMPELLER BORE - 1 1/8" MECHANICAL SEAL

ITEM 50 ADAPTER B.F. & A.I. CONSTRUCTION				
PUMP SIZE	MOTOR FRAME SIZE	MATERIAL	PART NUMBER	BAR CODE
1 1/2X1 1/2X6 2X2X6 3X3X6 4X4X6	143 - 145TC 182 - 256TC	CAST IRON	427700-011 427703-011	
1 1/2X1 1/2X8 2X2X8 3X3X8 4X4X8 5X5X8 6X6X8 8X8X8	143 - 145TC 182 - 256TC	CAST IRON	427701-011 427704-011	
2X2X10 3X3X10 4X4X10 6X6X10 8X8X10	143 - 145TC 182 - 256TC	CAST IRON	427702-011 427705-011	
4X4X11 1/2 5X5X11 1/2 6X6X11 1/2 8X8X11 1/2	182 - 256TC	CAST IRON	427706-011	

ADAPTERS CONTINUED ON PAGE 18

**VERTICAL IN-LINE - SPLIT COUPLER
MODEL 4300
PUMP PARTS FOR TC MOTORS
EQUAL SUCTION AND DISCHARGE**

GROUPS 1,2,3 & 4 - 7/8" IMPELLER BORE - 1 1/8" MECHANICAL SEAL

ITEM 50 ADAPTER D.I. & D.B.F. CONSTRUCTION				
PUMP SIZE	MOTOR FRAME SIZE	MATERIAL	PART NUMBER	BAR CODE
1 1/2X1 1/2X6 2X2X6 3X3X6 4X4X6	143 - 145TC	CAST IRON	427700-031	
	182 - 256TC		427703-031	
1 1/2X1 1/2X8 2X2X8 3X3X8 4X4X8 5X5X8 6X6X8 8X8X8	143 - 145TC	CAST IRON	427701-031	
	182 - 256TC		427704-031	
2X2X10 3X3X10 4X4X10 6X6X10 8X8X10	143 - 145TC	CAST IRON	427702-031	
	182 - 256TC		427705-031	
4X4X11 1/2 5X5X11 1/2 6X6X11 1/2 8X8X11 1/2	182 - 256TC	CAST IRON	427706-031	

ADAPTERS CONTINUED ON PAGE 19

**VERTICAL IN-LINE - SPLIT COUPLER
MODEL 4300
PUMP PARTS FOR TC MOTORS
EQUAL SUCTION AND DISCHARGE**

GROUPS 1,2,3 & 4 - 7/8" IMPELLER BORE - 1 1/8" MECHANICAL SEAL

ITEM 50 ADAPTER A.B. CONSTRUCTION				
PUMP SIZE	MOTOR FRAME SIZE	MATERIAL	PART NUMBER	BAR CODE
1 1/2X1 1/2X6 2X2X6 3X3X6 4X4X6	143 - 145TC	CAST BRONZE	427700-041	
	182 - 256TC		427703-041	
1 1/2X1 1/2X8 2X2X8 3X3X8 4X4X8 5X5X8 6X6X8 8X8X8	143 - 145TC	CAST BRONZE	427701-041	
	182 - 256TC		427704-041	
2X2X10 3X3X10 4X4X10 6X6X10 8X8X10	143 - 145TC	CAST BRONZE	427702-041	
	182 - 256TC		427705-041	
4X4X11 1/2 5X5X11 1/2 6X6X11 1/2 8X8X11 1/2	182 - 256TC	CAST BRONZE	427706-041	

**VERTICAL IN-LINE - SPLIT COUPLER
MODEL 4300
PUMP PARTS FOR TC MOTORS
EQUAL SUCTION AND DISCHARGE**

GROUPS 1,2,3 & 4 - 7/8" IMPELLER BORE - 1 1/8" MECHANICAL SEAL

ITEM 150 COUPLER GUARD			
PUMP SIZE	MOTOR FRAME SIZE	PART NUMBER	BAR CODE
1 1/2X1 1/2X6 2X2X6 3X3X6 4X4X6	143 - 145TC	427761-001	
	182 - 256TC	427761-003	
1 1/2X1 1/2X8 2X2X8 3X3X8 4X4X8 5X5X8 6X6X8 8X8X8	143 - 145TC	427761-001	
	182 - 215TC	427761-004	
2X2X10 3X3X10 4X4X10 6X6X10 8X8X10	143 - 145TC	427761-002	
	182 - 256TC	427761-005	
4X4X11 1/2 5X5X11 1/2 6X6X11 1/2 8X8X11 1/2	182 - 256TC	427761-005	

COUPLER GUARD FASTENERS					
ITEM NO.	DESCRIPTION	NO. REQ'D	SIZE	PART NUMBER	BAR CODE
151	BOLT - RD. HD.	2	#8-32 X 1 1/2"	916262-120	
152	NUT	2	#8-32	913162-116	
153	WASHER	2	#8-32	927105-100	

**VERTICAL IN-LINE - SPLIT COUPLER
MODEL 4300
PUMP PARTS FOR TC MOTORS
EQUAL SUCTION AND DISCHARGE**

GROUPS 1,2,3 & 4 - 7/8" IMPELLER BORE - 1 1/8" MECHANICAL SEAL

ITEM 44 MOTOR CAPSCREW & ITEM 43 LOCKWASHER				
PUMP SIZE	MOTOR FRAME SIZE	ITEM DESCRIPTION	PART NUMBER	BAR CODE
1 1/2X1 1/2X6 2X2X6 3X3X6 4X4X6	143 - 145TC	CAPSCREW	911121-108	
		LOCKWASHER	927211-100	
	182 - 256TC	CAPSCREW	911125-110	
		LOCKWASHER	927213-100	
1 1/2X1 1/2X8 2X2X8 3X3X8 4X4X8 5X5X8 6X6X8 8X8X8	143 - 145TC	CAPSCREW	911121-108	
		LOCKWASHER	927211-100	
	182 - 215TC	CAPSCREW	911125-110	
		LOCKWASHER	911125-110	
		CAPSCREW	911125-110	
		LOCKWASHER	911125-110	
2X2X10 3X3X10 4X4X10 6X6X10 8X8X10	143 - 145TC	CAPSCREW	911121-108	
		LOCKWASHER	927211-100	
	182-256TC	CAPSCREW	911125-110	
		LOCKWASHER	927213-100	
		LOCKWASHER	927213-100	
4X4X11 1/2 5X5X11 1/2 6X6X11 1/2 8X8X11 1/2	182 - 256TC	CAPSCREW	911125-110	
		LOCKWASHER	927213-110	

**VERTICAL IN-LINE - SPLIT COUPLER
MODEL 4300
PUMP PARTS FOR TC MOTORS**

EQUAL SUCTION AND DISCHARGE

GROUPS 1,2,3 & 4 - 7/8" IMPELLER BORE - 1 1/8" MECHANICAL SEAL

ITEM 147 MOTOR COUPLER COLLAR				
PUMP SIZE	MOTOR FRAME SIZE	PART NUMBER	BAR CODE	
1 1/2X1 1/2X6 2X2X6 3X3X6 4X4X6	143 -145TC	427748-000		
	182 - 184TC	427749-000		
	213 - 215TC	427750-000		
	254 - 256TC	427751-000		
1 1/2X1 1/2X8 2X2X8 3X3X8 4X4X8 5X5X8 6X6X8 8X8X8	143 - 145TC	427748-000		
	182 - 184TC	427749-000		
	213 - 215TC	427750-000		
	254 - 256TC	427751-000		
2X2X10 3X3X10 4X4X10 6X6X10 8X8X10	143 - 145TC	427748-000		
	182 - 184TC	427749-000		
	213 - 215TC	427750-000		
	254 - 256TC	427751-000		
4X4X11 1/2 5X5X11 1/2 6X6X11 1/2 8X8X11 1/2	213 - 215TC	427750-000		
	254 - 256TC	427751-000		

ITEM 146 MOTOR COUPLER COLLAR SET SCREW			
PUMP SIZE	MOTOR FRAME SIZE	PART NUMBER	BAR CODE
ALL	143 - 215TC	916517-106	
	254 - 256TC	916519-106	

**VERTICAL IN-LINE - SPLIT COUPLER
MODEL 4300
PUMP PARTS FOR TC MOTORS
EQUAL SUCTION AND DISCHARGE**

GROUPS 1,2,3 & 4 - 7/8" IMPELLER BORE - 1 1/8" MECHANICAL SEAL

ITEM 154 MOTOR KEY				
PUMP SIZE	MOTOR FRAME SIZE	PART NUMBER	BAR CODE	
1 1/2X1 1/2X6 2X2X6 3X3X6 4X4X6	143 -145TC	428160-708		
	182 - 184TC	428161-712		
	213 - 215TC	428162-115		
	254 - 256TC	428163-714		
1 1/2X1 1/2X8 2X2X8 3X3X8 4X4X8 5X5X8 6X6X8 8X8X8	143 - 145TC	428160-708		
	182 - 184TC	428161-712		
	213 - 215TC	428162-115		
	254 - 256TC	428163-714		
	143 - 145TC	428160-708		
	182 - 184TC	428161-712		
2X2X10 3X3X10 4X4X10 6X6X10 8X8X10	213 - 215TC	428162-115		
	254 - 256TC	428163-714		
	4X4X11 1/2 5X5X11 1/2 6X6X11 1/2 8X8X11 1/2	213 - 215TC	428162-115	
		254 - 256TC	428163-714	

**VERTICAL IN-LINE - SPLIT COUPLER
MODEL 4300
PUMP PARTS FOR TC MOTORS**

EQUAL SUCTION AND DISCHARGE

GROUPS 1,2,3 & 4 - 7/8" IMPELLER BORE - 1 1/8" MECHANICAL SEAL

ITEM 140 COUPLER			
PUMP SIZE	MOTOR FRAME SIZE	PART NUMBER	BAR CODE
1 1/2X1 1/2X6	143 -145TC	427731-000	
2X2X6	182 - 184TC	427732-000	
3X3X6	213 - 215TC	427733-000	
4X4X6	254 - 256TC	427734-000	
1 1/2X1 1/2X8	143 - 145TC	427731-000	
2X2X8	182 - 184TC	427732-000	
3X3X8	213 - 215TC	427733-000	
4X4X8	254 - 256TC	427734-000	
5X5X8	254 - 256TC	427734-000	
6X6X8	254 - 256TC	427734-000	
8X8X8	254 - 256TC	427734-000	
2X2X10	143 - 145TC	427731-000	
3X3X10	182 - 184TC	427732-000	
4X4X10	213 - 215TC	427733-000	
6X6X10	254 - 256TC	427734-000	
8X8X10	254 - 256TC	427734-000	
4X4X11 1/2	213 - 215TC	427733-000	
5X5X11 1/2	213 - 215TC	427733-000	
6X6X11 1/2	254 - 256TC	427734-000	
8X8X11 1/2	254 - 256TC	427734-000	

**VERTICAL IN-LINE - SPLIT COUPLER
MODEL 4300
PUMP PARTS FOR TC MOTORS
EQUAL SUCTION AND DISCHARGE**

GROUPS 1,2,3 & 4 - 7/8" IMPELLER BORE - 1 1/8" MECHANICAL SEAL

COMMON PARTS, ALL CONSTRUCTIONS

ITEM NUMBER	DESCRIPTION	PART NUMBER	BAR CODE
21	1 1/8" PUMP SHAFT	427713-000	
36	IMPELLER KEY	428160-708	
51	SEAL CHAMBER BUSHING	425520-002	
83	IMPELLER WASHER	425742-001	
86	IMPELLER CAPSCREW	911900-114	
102	GAUGE PLUG (4 REQ'D) 1/4"NPT. CAD PLATED	937105-201	
144	COUPLER CAPSCREW (6 REQ'D) FRAMES 143 TO 215TC	911819-112	
144	COUPLER CAPSCREW (6 REQ'D) FRAME 254/256TC	911821-116	
145	LOCKWASHER (FOR ITEM 144) FRAMES 143 TO 215TC (6 REQ'D)	927210-100	
145	LOCKWASHER (FOR ITEM 144) FRAME 254/256TC	927211-100	
148	COUPLER COLLAR (PUMP SHAFT)	427756-000	
149	CPLR. KEY (PUMP SHAFT)	428161-106	
155	CAPSCREW LOCKWASHER	927211-400	
156	COLLAR CAPSCREW	911121-106	

**VERTICAL IN-LINE - SPLIT COUPLER
MODEL 4300
PUMP PARTS FOR TC MOTORS
EQUAL SUCTION AND DISCHARGE**

GROUPS 1,2,3 & 4 - 7/8" IMPELLER BORE - 1 1/8" MECHANICAL SEAL

PARTS FOR 1 1/8" OUTSIDE SEAL

ITEM NO.	DESCRIPTION	CONSTRUCTION	PART NUMBER	BAR CODE
62	MECHANICAL SEAL			
	ARMSTRONG SEAL	ALL	975002-304	
	DURAMETALLIC STD.	ALL	975002-003	
	DURAMETALLIC T.C.	ALL	975002-001	
	JOHN CRANE STD.	ALL	975000-955	
	JOHN CRANE T.C.	ALL	975000-965	
103	CAPSCREW - 4 REQ'D 3/8"-16NCX1 1/2" S/S	ALL	911121-416	
104	WASHER - 4 REQ'D 3/8" FLAT	ALL	427114-100	
54	SEAL COVER	BF - DBF - AB	426484-002	
		AI - DI	426484-001	

NOTES:

BF - DBF - AB ---- DENOTES BRONZE FITTED - DUCTILE BRONZE FITTED - ALL BRONZE

AI - DI ----- DENOTES ALL IRON - DUCTILE IRON

**VERTICAL IN-LINE - SPLIT COUPLER
MODEL 4300
PUMP PARTS FOR TC MOTORS
EQUAL SUCTION AND DISCHARGE**

GROUPS 1,2,3 & 4 - 7/8" IMPELLER BORE - 1 1/8" MECHANICAL SEAL

PARTS FOR 1 1/8" INSIDE MECH. SEAL ARRANGEMENT				
ITEM NO.	DESCRIPTION	CONSTRUCTION	PART NUMBER	BAR CODE
62	MECHANICAL SEAL	ALL	810150-143	
52	CAPSCREW - 4 REQ'D 3/8" - 16NC X 1" S/S	ALL	911121-408	
163	WASHER - 4 REQ'D 3/8" FLAT	ALL	427114-100	
54	SEAL COVER	BF - DBF - AB	426464-011	
		AI - DI	426464-001	
55	GASKET	ALL	426467-001	
160	RETAINING RING	ALL	923104-434	

NOTES:

BF - DBF - AB ---- DENOTES BRONZE FITTED - DUCTILE BRONZE FITTED - ALL BRONZE

AI - DI ----- DENOTES ALL IRON - DUCTILE IRON

**VERTICAL IN-LINE - SPLIT COUPLER
MODEL 4300
PUMP PARTS FOR TC MOTORS
EQUAL SUCTION AND DISCHARGE**

GROUPS 1,2,3 & 4 - 7/8" IMPELLER BORE - 1 1/8" MECHANICAL SEAL

STANDARD MECHANICAL SEAL FLUSH LINE PARTS					
ITEM NO.	DESCRIPTION	NO. REQ'D	CONSTRUCTION	PART NUMBER	BAR CODE
58	MALE STRAIGHT CONN. 3/8" TUBE X 1/4"NPT	1	AB - BF - DBF	939001-114	
			AI - DI	939001-314	
59	TUBING 20" REQUIRED 3/8"OD X .035 WALL	20"	AB - BF - DBF	997531-004	
			AI - DI	997153-004	
63	TEE 1/4" NPT	1	AB - BF - DBF	935101-001	
			AI - DI	931101-101	
64	BUSHING 1/4" MNPT X 1/8" FNPT	1	AB - BF - DBF	935123-050	
			AI - DI	931123-150	
67	NIPPLE 1/4" NPT X 2 1/2" NPT	1	AB - BF - DBF	938103-001	
			AI - DI	938003-101	
68	AIR VENT	1	AB - BF - DBF	939018-101	
			AI - DI	218644-000	
194	MALE 90 DEG. CONN. 3/8" TUBE X 1/4"NPT	1	AB - BF - DBF	939003-109	
			AI - DI	939003-309	

FOR OTHER FLUSH LINE OPTIONS, SEE FLUSH LINE OPTIONS PARTS LIST