

ARMSTRONG



Zone Tertiary Controller

FILE NO:	90.16IN
DATE:	Sep. 10, 2010
SUPERSEDES:	New
DATE:	New

Intelligent Solution for Tertiary Zone Control



Tertiary pumping systems have gained prominence with the increase in district cooling and large integrated complexes, some of which include townships and technology parks. The primary systems serve as the generation loop while the secondary and tertiary system serves as the distribution loop.

The Armstrong ZTC3000 Tertiary controller receives temperature sensor inputs and modulates the tertiary zone 2-way control valve.

- ▶ This ensures thermal independence (i.e. each zone can be supplied with different temperatures)
- ▶ Building systems can be cooled and dehumidified by providing the correct flow at the highest temperature, thereby increasing the chiller performance

The ZTC 3001 receives temperature inputs from three temperatures sensors installed in the system, T1 (Zone entering temperature), T2 (Zone return temperature) and T3 (supply temperature), and modulates the control valve to achieve optimum occupant comfort.

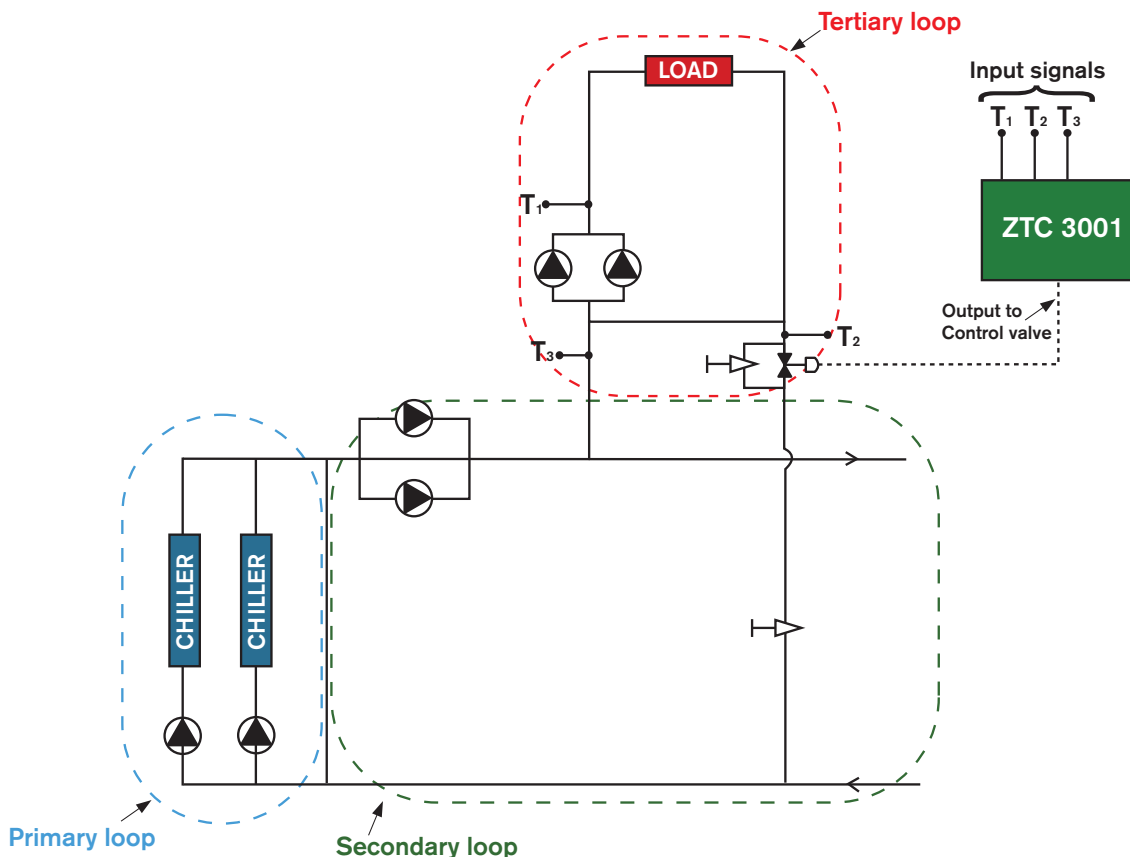

Zone Tertiary Controller

▶ CUSTOMER BENEFITS

- ▶ Pre-engineered, factory built and tested for smooth commissioning
- ▶ Simple time saving installation
- ▶ Reduced site errors for faster project completion
- ▶ Standardization of components offers familiarity from project to project
- ▶ Easy adjustment of System settings
- ▶ Expert support from the design stage to operation
- ▶ Easy access to records of faults and alarms
- ▶ Simple to operate and maintain
- ▶ Easy recovery to operating status using built-in diagnostics
- ▶ User-friendly interface for access to system data
- ▶ Maximum occupant comfort due to improved system stability
- ▶ Connectivity to standard BMS systems

▶ FEATURES

- ▶ Wall mounted IP54/IP55 enclosure
- ▶ Field modifiable set points
- ▶ Adjustable PID control loop
- ▶ Remote on/off signal
- ▶ Temperature inputs/readouts
- ▶ Fused 24 volt power supply
- ▶ 4-line x 20-character LCD display
- ▶ Two levels of password security
 - ▶ One for field adjustable parameters
 - ▶ One for factory/commissioning setup parameters
- ▶ Data-logging feature captures alarms and events
- ▶ Multi-fault memory and recall
- ▶ Serial communications with Modbus, LonWorks, Trend, and Metasys protocols
- ▶ Gateways for BACnet and TCP/IP protocol connection for communication over the internet.
- ▶ Auto purge set-up
- ▶ PLC clock
- ▶ Alarm management displays

▶ TYPICAL SPECIFICATION

▶ Mechanical and Electrical Details

The Zone Tertiary Controller (ZTC) logic controller shall be Armstrong ZTC Controller 3001. The ZTC3001 zone tertiary controller shall be specifically designed for the control water supply to the zone to assure maximum allowable temperature rise and minimum flow demand on the plant. It shall address chilled or hot water as a resource and control this resource on a pre-determined and pre-programmed basis

The ZTC3001 zone tertiary controller shall allow field adjustments of control parameters as described below.

The controller shall be capable of accepting and processing appropriate signals (temperature) for the following dedicated terminal blocks.

- ▶ 3 analog inputs (AI) for temperature transmitter signals 4-20 mA
- ▶ 1 Digital (DI) for remote connection for start/stop
- ▶ 1 Analog Output (AO) modulating valve actuator position signal,
- ▶ 2 Digital Output (DO) for alarms: (a) alarm Horn (Buzzer) (b) general system alarm
- ▶ 1 serial port for communication with the BMS
- ▶ 1 terminal block for power supply 230 VAC/1 ph/50 Hz

The ZTC3001 zone tertiary controller shall have an internal circuit breaker. The logic controller shall be based on flash style memory, older style EEPROM style memory is unacceptable.

The ZTC3001 controller shall include a 4-line x 20-character LCD display with soft illuminated button keypad for all necessary user interface functions. LED displays will not be accepted. The ZTC controller logic controller shall perform online self-diagnostic testing of the CPU(s), RAM, and flash memory. No data shall be lost during power supply interruptions. The logic controller shall have an IP54/IP55 rated cabinet.

The ZTC3001 controller shall have two levels of password security, one level for field adjustable parameters, a second for factory/commissioning setup parameters.

▶ Performance and Operating Logic

The ZTC3001 logic controller shall determine the most efficient operating valve based on the zone temperature sensor signals. The ZTC3001 controller can permit the integration of all the sensor inputs into a control algorithm. The algorithm must address the following criteria:

- ▶ Zone supply temperature control to the zone,
- ▶ If zone supply temperature is satisfied and then return water temperature to the chillers plant
- ▶ Monitor secondary chilled water supply temperature for temperature increase due to secondary return water recirculation or temperature decrease due to chillers leaving water temperature reset. Reference point for automatic reset and DT (Chilled water supply/return water temperature) control.

When this control algorithm is satisfied, three system objectives will be obtained:

- ▶ Satisfy zone BTU requirements at the maximum supply temperature possible. Maximum temperature to the zone decreases delta T, which increases flow rate through coil and across the control valve. Increased flow rate is accomplished through tertiary recirculation, reducing flow contribution from the secondary supply.
- ▶ Minimize secondary flow rate. By reducing the secondary flow requirement, the secondary pumps operate at lower flows. Lower flow, whether the secondary pumps are variable speed or constant speed, means reduction in pumping energy.
- ▶ Optimize return water temperature to chiller plant. Increased temperature from the chillers ensures the chillers operate more efficiently. Less supply water required by the zones means fewer chillers in operation.

The ZTC3001 logic shall incorporate an adjustable PID control loop. The ZTC controller should provide the option for a remote on/off signal from a single dry type relay, or BMS communication signal.

The ZTC controller shall provide a data-logging feature including alarms, and events (adjustment to system parameters).

The ZTC controller shall offer the option for expanded memory of 4 MB for a rolling record of 10 system parameters. The logic controller shall be self-prompting. All messages displayed in plain English. The operator interface shall have multi-fault memory and recall, on-screen help functions, and separate user screens for:

- ▶ Main menu
- ▶ Temperature display
- ▶ Zone supply temperature
- ▶ Zone return temperature
- ▶ Zone valve control

The ZTC controller shall be capable of serial communications with Modbus, LonWorks, Trend, and Metasys protocols. The ZTC controller shall offer the option of gateways for BACnet and TCP/IP protocol connection for communication over the internet.

The ZTC logic controller shall have auto purge set up.

S. A. Armstrong Limited
23 Bertrand Avenue
Toronto, Ontario
Canada, M1L 2P3
T: (416) 755-2291
F (Main): (416) 759-9101

Armstrong Integrated Limited
Wenlock Way
Manchester
United Kingdom, M12 5JL
T: +44 (0) 8444 145 145
F: +44 (0) 8444 145 146

Armstrong Design Private Ltd.
(Unit 1- Armstrong Manufacturing Center)
490-L, 4th Phase, Peenya Industrial Area,
Bangalore, India 560 058
T: +91 (80) 4149 2832
F: +91 (80) 4149 2831

