

ARMSTRONG



Instantaneous Hot Water Units

FILE NO:	15-1
DATE:	July 2010
SUPERSEDES:	15-1
DATE:	July 2007

Fast Regulated Packaged Instantaneous Hot Water Units



Response 2000 packaged instantaneous hot water supply units have been designed to encompass the very latest in heat transfer and control technology. The unique Armstrong packaging concept has also been incorporated to produce a compact yet practical design which eliminates the need for external spray guards. Together with a wide choice of options, this provides a very efficient solution to most hot water supply demands.

► Applications

Response 2000 IHW units are ideally suited to satisfy the continuous demands for hot water as required in hotels, schools, hospitals, nursing homes, sports complexes and in many industrial applications.

They can also be used in retro-fit situations where space is restricted when existing calorifiers need replacing or upgrading.

► Advantages

These units provide an efficient method of generating hot water through the use of stainless steel plate heat exchangers. Their low water content and low thermal inertia makes them ideal for use in systems with rapidly changing hot water demands. They can eliminate the need for hot water storage, although some applications can call for a small buffer tank*. However, it is advisable to minimise the storage of hot water for long periods as the risk of legionella bacteria will increase.

*As an alternative to a larger boiler, a buffer tank may be installed to assist for short periods of peak demand.

Instantaneous Hot Water Units

► Response 2000 Product Range

Armstrong's Response 2000 packaged units are manufactured in two cabinet sizes:

► Model 032/40 (Small Cabinet).

300kW max. at 82°C primary flow.

For outputs up to 300kW. Incorporates a plate heat exchanger, single primary pump, three or four port control valve, electrical control panel, pipework and valves.

► Model 032/50 - 150/50 (Standard cabinet).

1200kW max. at 82°C primary flow.

Accommodates capacities up to 1200kW, and incorporates a plate heat exchanger, single or twin primary pumps, three or four port control valve, electrical control panel, pipework and valves.

A single secondary pump can also be included in both package units.

All cabinets are clad in plastic-coated galvanized dipped-steel sheeting which provides an extremely safe and clean environment for the equipment.

Notes:

1. For the effective operation of this product primary flow temperatures MUST be stable.
2. Armstrong recommends the fitting of isolating valves, available as an extra.

► Available Options

- Twin Head Pump
- Single-phase Supply
- Secondary Pump
- Three/Four-port Control Valve
- Pressure Relief Valve
- Non-return Valve
- Time Clock
- Double check Valve
- Pressure Gauge
- Set back facility or RS485 communications

Control Features

- Door-interlocked mains disconnect switch on the control panel.
- Volt-free contacts for Pump Run and Tripped, High Temperature and Power On. Each function is indicated visually.
- PID temperature controller Combined adjustable thermal overload/short-circuit protection and high temperature contact within the motor body for complete pump protection. All 032/40 units motors are protected by internal thermostat and circuit breaker.
- Mimic display to provide clear indication of equipment status.
- Setback facility for PID temperature controller.
- Additional display showing set point and actual temperature.

Instantaneous Applications

► To Select a Response 2000 Unit

- Select the required secondary flow rate, e.g. 4.5 l/s.
- Extend vertically to the intersection of the design primary flow temperature curve - 82°C.
- At this point project horizontally to select the required number of plates - 43 (selection table gives nearest number of plates as 45).
- At the same point in (3) extend again vertically to the intersection of the Heat Load curve.
- Project horizontally to give required heat load - 940kW.

Therefore the unit required = 150/50 with 45 plates having a heating capacity of 940kW and requiring a primary flow rate of 5.5 l/s at 82°C (using either a three or four port valve).

Semi-Instantaneous Applications

Use Buffer Vessel(s) with Response 2000 Unit when available boiler power output is limited.

► To Select Buffer Vessel

- Start at maximum boiler kW available.
- Project horizontally to intersection of Buffer Vessel curve and required Flow Rate to read vessel size.

► To Select Response Unit for use with Buffer Vessel

- Start at maximum boiler kW available.
- Project horizontally to intersect with Heat Load curve.
- Project up (or down) accordingly, to intersect with required flow temperature curve. This will give the necessary size of unit.
- Project horizontally to the right to determine the number of plates required.

► Selection Chart for Response 2000 Units and Buffer Vessels

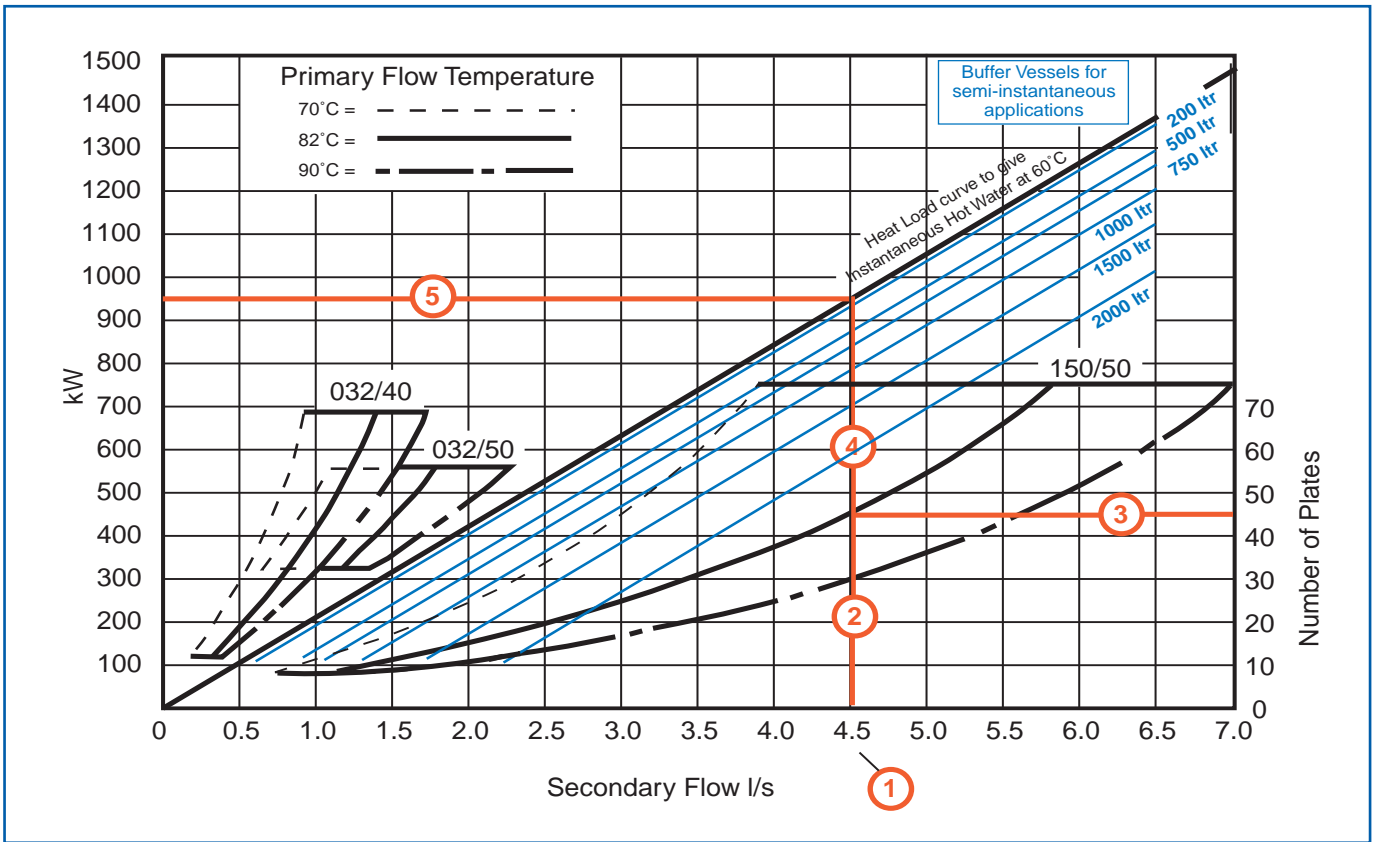

► Selection Table for Response 2000 Units

Model 032/40	70PC		82PC		90PC	
	Sec. PD. KPa	Primary Flow l/s	Sec. PD. KPa	Primary Flow l/s	Sec. PD. KPa	Primary Flow l/s
11	3.2	0.47	12.2	0.61	18.8	0.58
15	3.7	0.68	12.6	0.80	19.0	0.77
21	4.4	1.07	12.5	1.07	19.2	1.05
27	4.4	1.31	11.8	1.27	18.6	1.28
33	4.0	1.43	11.5	1.47	17.7	1.46
41	3.8	1.60	10.4	1.62	16.4	1.64
47	3.7	1.74	10.2	1.77	15.4	1.74
55	3.5	1.82	9.6	1.89	14.8	1.90
63	3.6	2.02	9.2	2.01	13.8	1.98
69	3.5	2.08	8.9	2.07	13.5	2.05

Model 032/50	70PC		82PC		90PC	
	Sec. PD. KPa	Primary Flow l/s	Sec. PD. KPa	Primary Flow l/s	Sec. PD. KPa	Primary Flow l/s
31	6.8	2.40	19.9	2.32	32.5	2.36
33	6.6	2.39	20.8	2.56	32.9	2.52
37	6.9	2.77	20.4	2.74	32.8	2.75
39	6.7	2.77	20.6	2.88	32.4	2.84
43	6.7	2.97	20.4	3.07	32.6	3.08
49	7.0	3.36	20.0	3.31	32.2	3.34
53	7.0	3.56	20.2	3.51	32.1	3.52
57	6.8	3.59	19.9	3.62	32.3	3.70

Model 150/50	70PC		82PC		90PC	
	Sec. PD. KPa	Primary Flow l/s	Sec. PD. KPa	Primary Flow l/s	Sec. PD. KPa	Primary Flow l/s
9	14.0	1.83	30.3	1.56	57.5	1.90
11	14.8	2.22	29.8	1.82	59.5	2.32
13	15.4	2.63	30.4	2.14	59.7	2.69
15	15.8	3.03	30.2	2.24	58.8	3.03
17	15.6	3.34	30.6	2.75	58.2	3.37
19	15.5	3.65	30.5	3.03	57.8	3.72
21	15.1	3.87	30.6	3.32	56.1	3.98
23	14.7	4.10	30.5	3.60	53.5	4.17
25	14.4	4.34	30.3	3.89	51.4	4.37
27	13.6	4.40	30.3	4.18	49.7	4.57
29	13.5	4.65	30.3	4.47	48.3	4.77
31	12.9	4.73	30.3	4.75	46.2	4.90
33	12.8	4.98	30.3	4.95	44.5	5.04
37	12.0	5.18	30.4	5.18	41.1	5.26
41	11.3	5.40	29.8	5.42	37.9	5.42
45	10.6	5.50	27.7	5.51	35.5	5.60
49	10.0	5.61	26.1	5.69	32.7	5.67
53	9.5	5.74	24.0	5.73	30.9	5.81
57	9.1	5.88	22.8	5.86	29.0	5.90
61	8.6	5.91	21.1	6.00	27.2	5.94
65	8.4	6.07	20.2	6.07	26.0	6.04
69	8.0	6.12	17.6	6.14	25.1	6.15
73	7.7	6.17	16.7	6.16	23.7	6.16

► Schematic for Instantaneous Unvented System

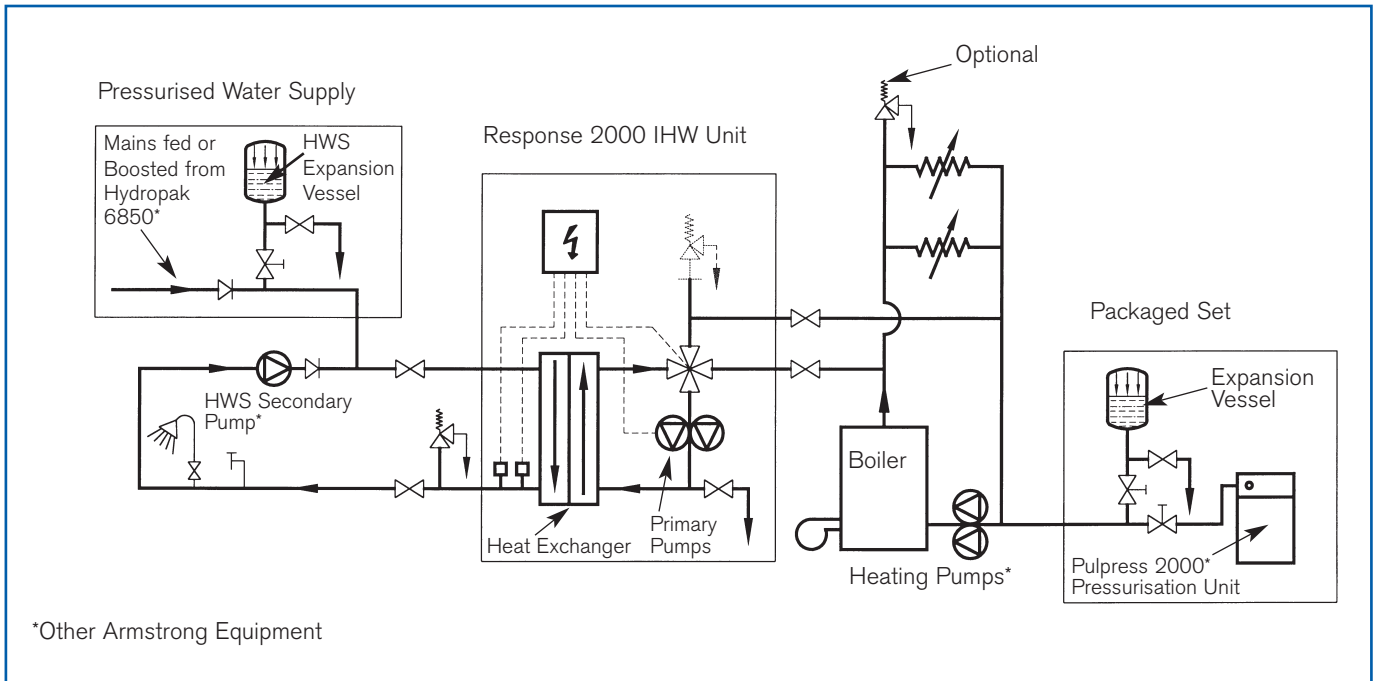

► Buffer Vessels

Standard Range Specification

Part No.	52041	52042	52043	52044	52045	52046	
Capacity litre	200	500	750	1000	1500	2000	
Dimensions	ABSPM	1"	1 1/4"	1 1/4"	1 1/4"	2"	2"
	BBSPF	3/4"	3/4"	3/4"	3/4"	3/4"	3/4"
	CBSPM	1"	1 1/4"	1 1/4"	1 1/4"	2"	2"
	DBSPF	1 1/2"	1 1/2"	1 1/2"	1 1/2"	1 1/2"	1 1/2"
	EBSP	3/4"F	1"M	1"M	1"M	3/4"F	3/4"F
	F mm	-	120	120	120	2x120	2x120
	G* mm dia.	710	910	910	960	1160	1260
H mm	1160	1500	2000	2260	2350	2470	
Weight kg	53	125	155	200	350	4202	

Maximum operating temperature 95°C.

Maximum operating pressure 10 bar.

Optional Extra

80mm thick insulation.

* Measurement shown inclusive of insulation.

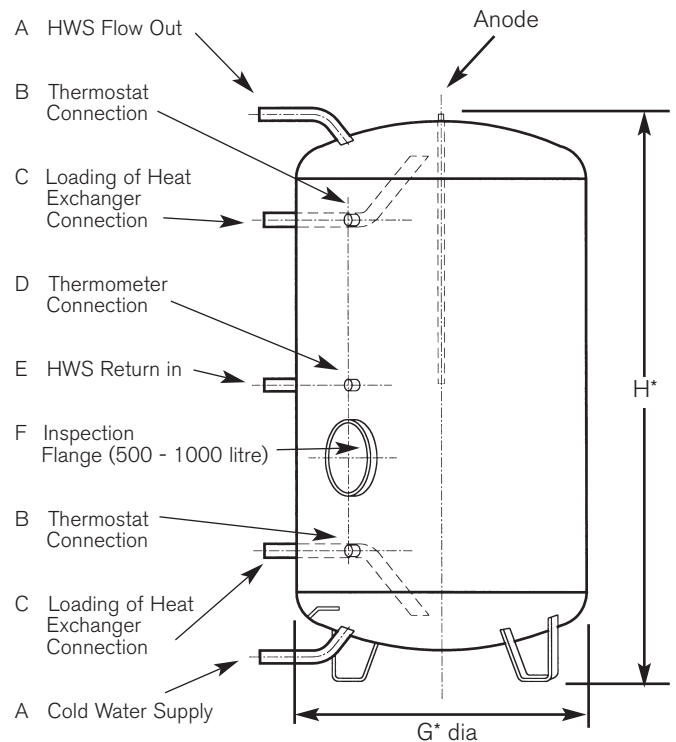

► Dimensions of Units and Recommended Installation Details

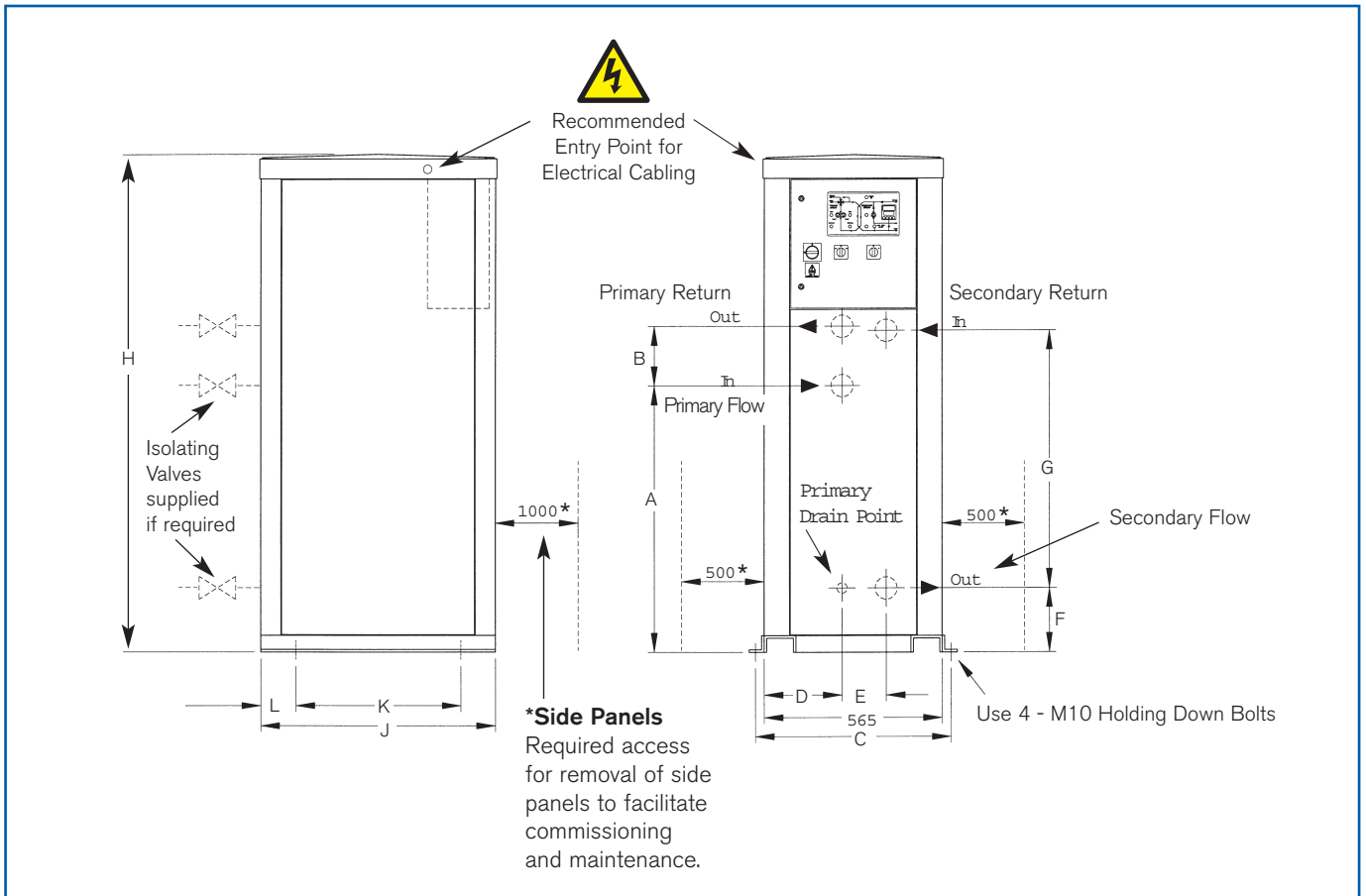

Dimensions	Unit Type					
	032/40 4 Port	032/40 3 Port	032/50 4 Port	032/50 3 Port	150/50 4 port	150/50 3 port
A	786	902	680	850	840	1020
B	116	70	180	120	175	90
C	600	600	625	625	625	625
D	252	252	243	243	238	238
E	60	60	60	60	140	140
F	150	150	200	200	200	200
G	360	360	800	800	800	800
H	1070	1070	1550	1550	1550	1550
J	565	565	745	745	745	745
K	443	443	545	545	545	545
L	60	60	100	100	100	100
Max. Weight kg	110	110	300	300	320	320
Connection Sizes						
Primary Flow	1½" BSPF	1½" BSPF	2" BSPF	2" BSPF	2" BSPF	2" BSPF
Primary Return	1½" BSPF	1½" BSPF	2" BSPF	1¼" BSPF	2" BSPF	2" BSPF
Secondary Flow/ Return	1½" BSPF	1¼" BSPF	1¼" BSPF	1¼" BSPF	2" BSPF	2" BSPF

Materials of Construction

► Pumps

Primary: MF (Single or Twin) canned rotor.
Body: Grey cast iron.
Internals: Stainless steel.
Impellers: Noryl.

Secondary: (Optional) MFX canned rotor.
Body: High grade bronze.
Internals: Stainless steel.
Impellers: Noryl/stainless steel.

► Control Cubicle

Zintec-coated rolled steel enclosure with stove enamel polyester powder coat finish.
Lockable enclosure door with IP54 rating.
Motors are switched direct-on-line employing circuit breakers with thermal and magnetic trips.
Control circuit protected by miniature circuit breaker.
Mains disconnection by door-interlocked switch.
Temperature controller dual four-digit red LED display with sealed front panel to IP65.
Manufactured to comply with EN55101 and EN55022 EMC specifications.

► Valves

Rotary plug-valve
(3 or 4 port): Grey cast iron.
Valve actuator: Electric 90° angular rotation with IP54 protection.
Drain valve: 1/2" BSP brass.

► Sensors

Temperature sensor thermocouple: Type J complete with stainless steel armour sheath.
High temperature thermostat: Range 25 - 95°C with manual reset.

► Pipework

Black steel medium gauge to BS1387, with fittings to BS143/1256.
Copper pipework manufactured to EN1057 Table X.

► Baseframes

Welded fabrication from mild steel sections, complete with lifting and securing facilities.
Base fabricated from galvanized steel on Model 032/40.

► Cladding

Polyester coating on hot-dipped zinc-coated steel.

► Buffer Vessels

Body: Mild steel lined with glass.

► Heat Exchanger

Heat transfer plates: Stainless steel AISI 316.
Gasket clip: Type EPDM double-sealed at ports.
Pressure plates: Mild steel.
Tie bolts: Zinc-plated steel.
Guide bars: Mild steel.
Maximum primary temperature 120°C, pressure 6 bar.

Our policy is one of continuous improvement and we reserve the right to alter our dimensions and specifications without notice

Armstrong Integrated Limited
Wenlock Way
Manchester
United Kingdom, M12 5JL
T: +44 (0) 8444 145 145
F: +44 (0) 8444 145 146

S. A. Armstrong Limited
23 Bertrand Avenue
Toronto, Ontario
Canada, M1L 2P3
T: 001 416 755 2291
F: 001 416 759 9101

