

# ARMSTRONG



## Glandless Circulators

FILE NO:	1-2
DATE:	July 2010
SUPERSEDES:	1-2
DATE:	July 2007

# Variable Speed Glandless Circulators

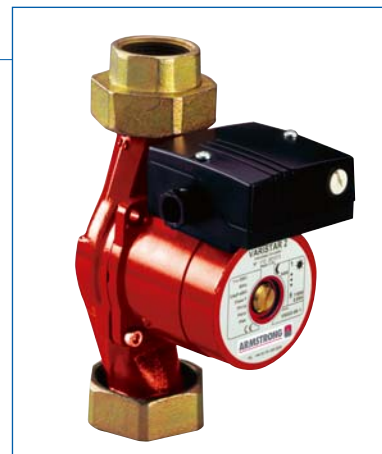

This single phase circulator has a wet rotor with the bearings being lubricated by the circulator liquid.

The units are self regulating and adjust to the pressure needs of the installation.

► **Model Numbers - VSS 22-03, 32-05.**

► **Application**

VSS22 and VSS32 circulators are ideally suited for circulating water in heating circuits on applications such as small commercial buildings, large houses, green houses etc.

They adapt readily to new and retrofit applications where extensions to the heating system are required. Recommended for installations using thermostatic (two port) valves.

► **Operation**

The terminal box cover on VSS22-03 and 32-05 has two switches which are set during commissioning to determine the control mode. The switches on the two models differ as described below.

► **VSS22 - 03**

Use switch (A) to select constant pressure operation with variable speed.

Use switch (B) to select variable pressure operation with variable speed.

Two curves are available on each switch. The factory setting is curve 1 on switch B. (See performance charts).

► **VSS32-05**

Use the knob to select the optimal circulator curve to suit the system. The numbers 1-5 indicate the head in metres. Intermediate values can be selected. Switch (A) operates as on the VSS22-03. Switch (B) differs as below:

<p>VSS 32-05 adjuster knob</p>	<p>Terminal Box Cover</p>	<p>VSS 22-03 switch</p>	<p>VSS 32-05 switch</p>

The ☾ activates automatic control of the pressure differential in night set - back operation. VSS32-05 is delivered set to the ☀ in variable pressure mode.

# Single and Duty Standby Units

## ► Noise Levels and Control

The electronically self-regulating circulator matches the speed of rotation according to the loss of head in the system to maintain efficiency and keep the noise level as low as possible. Noise levels are kept to a low despite erratic thermostatic control valve operation. The VSS22 and 32 adjust the speed as the thermostatic valves open and shut.

- Elimination of whistling and of thermostatic valve noise.
- Quieter, automatically adjusts its speed to heating requirement.

## ► Advantages

Day/night boiler control systems are now common. By reducing the flow temperature at night, energy savings are made with the boiler. The circulator continues to pump the cooler water at the same rate. The VSS22 and 32 can also save energy by sensing the lower temperature and reducing the speed accordingly. It automatically switches to the 'night' curve, yielding up to 40% energy savings.

The units start at a maximum torque (this prevents sticking), and have electronic servo control independent of motor electricals.

## ► Easier Selection

Can be installed on combination boiler systems and has two control modes to suit many systems.

## ► Simple and Quick to Install

Fully automatic operation with no maintenance or adjustment, eliminating the need for a differential valve. Simplifies adjusting the control valve (constant pressure difference option).

## ► Single Circulators with Screwed Connections

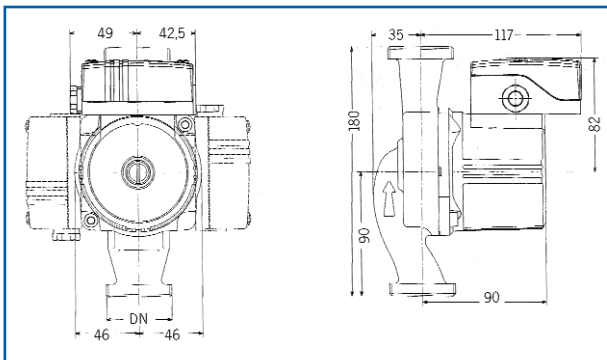

Circulators must always be installed with the shaft horizontal, vertical shaft position is not allowed. Configurations shown are the only ones acceptable.

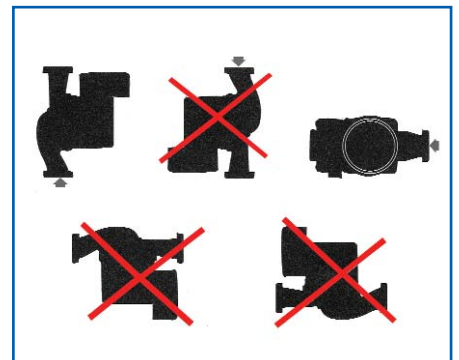

## ► Features

### 1. Electrical

Single-phase 230V, 50Hz with capacitor built into terminal box. Motor protection not required.

### 2. Installation

Motor shaft always horizontal.

Connection to installation on threaded pipe:

- VSS22-03 c/w 1" BSP unions
- VSS32-05 c/w 1 1/4" BSP unions

### 3. Packaging

Supplied complete with gaskets and unions.

### 4. Maintenance

Standard exchange of circulator.

Electronic servo control kit.

In the event of a malfunction, Varistar 2 - 22-32 circulators switch automatically to their maximum hydraulic curve.

## Motor Circulator Details VSS22-03, VSS32-05

Order Reference	P1 Watts Min-Max	Full Load Amps	Speed r.p.m. Min	Speed r.p.m. Max	Connected to threaded pipe by:
VSS22-03	45-85	0.45	1200	1900	1" BSP Unions
VSS32-05	34-116	0.55	600	2500	1 1/4" BSP Unions

### ► Application

Varistar 2's variable speed circulators are specified for heating systems with two port control or thermostatic control valves where variable water volume is required. Available with a range of control options. Varistar 2 offers energy savings and quiet operation.

### ► Operation

Heating requirements in buildings change seasonally, daily and between day and night. Thermostatic control valves are used to adjust the heat input into diverse zones in buildings. The variable speed Varistar 2 is specified to automatically adjust its speed so that the differential head is maintained at optimal requirement, saving energy and cutting operating noise levels. Varistar 2 adjusts automatically to match the operation of thermostatic control valves.

### ► Manual Adjustment:

Setting up of the basic functions, i.e.

- On/off. • Control mode  $\Delta P$  constant,  $\Delta P$  variable .
- Speed adjustment. • Automatic reduction for minimum speed.

Constant pressure (  $\Delta P \square$  ). In this regulation mode, the electronics maintains the differential pressure of the circulator constant whatever the flow-rate depending on the predefined pressure set point.

Variable pressure (  $\Delta P \sphericalangle$  ). Varistar 2, in pressure control mode, reduces the generated pressure as the flow requirement falls to suit the differential set pressure.

Speed adjustment: The speed can be adjusted manually to a constant value of between 850 and 2850 rpm.

Automatic idling: The development of day/night controls extensively use reduced boiler operation temperatures at night to save energy. However, potential circulator power savings have been overlooked.

### ► VSS/VSD

VSS/VSD equipment controls the speed of rotation relative to the temperature of the water being conveyed and therefore prevents any unnecessary consumption. If a significant reduction in the water temperature is detected, the temperature sensor automatically controls the switch over of the circulator to the "night" curve. This function saves 25% additional energy.

As soon as a temperature rise is detected, the circulator returns to its predetermined operating curve.

### ► External Control

This mode deactivates control in the electronic module:

- External speed regulation is by 0 - 10V signal.
- External on/off control. • Fault transfer.

The choice between variable pressure or constant pressure operation has to be determined according to the load loss curve and the specific nature of the installation. As far as automatic idling is concerned, it is designed for night times or low-load operation.

## ► Twin Head Glandless Circulators

With two IF (interface) modules, the VSD units boast the following additional functions:

### ► Duty/Standby

The required flow-rate is applied by a single circulator while the other circulator only starts in the event of the first circulator failing or after it has been running for a full 24-hours.

### ► Duty/Support

At minimum load, only the circulator in service operates. The back-up circulator engages when the radiators require more flow. From this point on (switching point), the nominal speed of the two circulators increases synchronously as the need arises. After 24-hours of effective operation, the master circulator switches over and becomes slave circulator. This function increases energy saving over conventional parallel operation by avoiding many engaging/tripping sequences. (See duty/support curves).

## ► Advantages

#### ► Energy Savings:

Optimisation of circulator's operating point. Energy savings of up to 50% compared with a conventional circulator.

#### ► Versatility:

These circulators are ideally suited to new and retrofit applications and can be readily fitted to most basic systems.

#### ► Noise Control:

Product eliminates hiss and noise of thermostatic valves. Adapts speed automatically to comfort requirements.

#### ► Reliability:

- All automatic operation totally free of maintenance and purging.
- Circulators defined by on/off control feature starting for a few moments each day to avoid any blocking due to periods of inactivity.
- Electronic module equipped with non-volatile memory for data storage - protection of instructions in the event of a power cut.
- Twin circulator versions (equipped with IF module as option) provides automatic changeover without the need for external switching.

Minimum Suction Head Required (m.w.g.) versus operating temperature			
Type	82°C	90°C	95°C
VSS22-03-1	1.5m	3.0m	10.0m
VSS32-05-1			

## Circulator Identification Plate

**VSS 32 - 05 - 1**

- Electronic module \_\_\_\_\_
- Single circulator \_\_\_\_\_
- Twin circulator (D) \_\_\_\_\_
- Nominal diameter of flange \_\_\_\_\_
- Discharge head in metres \_\_\_\_\_
- Phase \_\_\_\_\_

## ▶ Operating Curves - Variable Speed VSS Single Circulator Unit Model Numbers - VSS/VSD 42-10, 52-08, 52-11, 62-09, 82-12.

Operation at Constant  $\Delta P$

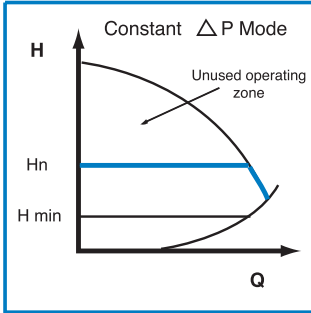

Varistar 2 controls the differential pressure set point ( $H_n$ ) at a constant value, irrespective of the water flow rate, from a minimum to maximum flow.

Operation at Variable  $\Delta P$

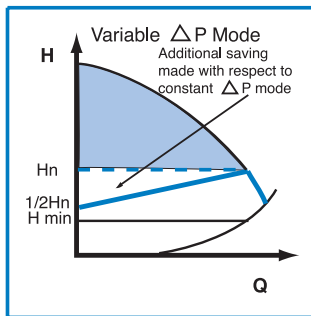

Varistar 2 controls the differential set point pressure between  $H_n$  at maximum flow and  $H_n \times 0.5$  at minimum flow. Thus the set point pressure increases as flow rate increases and vice - versa.

### Connection (IF Module)

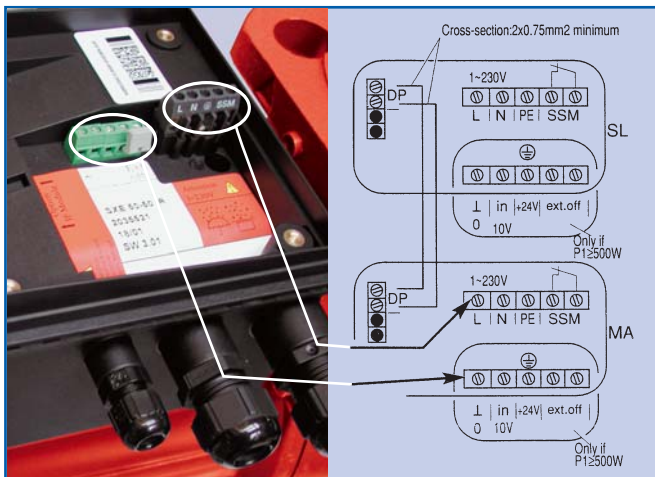

Operation With Automatic Idling

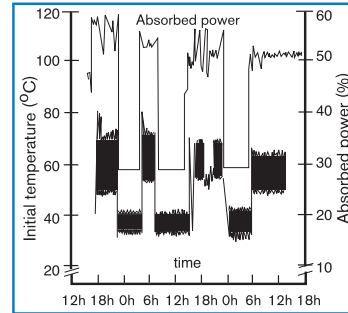

This operating mode offers 25% extra energy saving compared to operation at constant ( $\Delta P$ ) pressure mode. Operating speed is reduced to a constant low speed when liquid temperature falls below a specified value. Normal operation is resumed when liquid temperature rises.



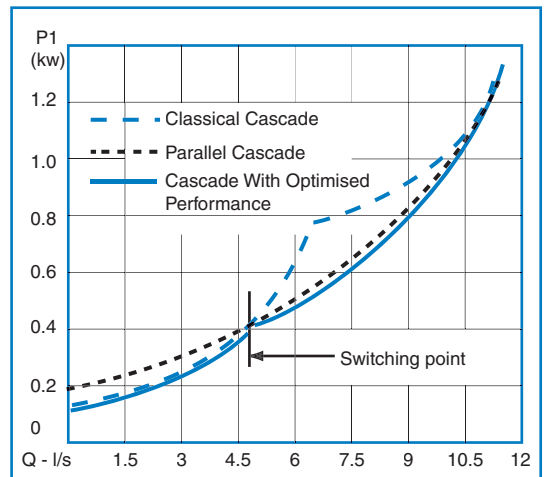





### Synchronised Cascade Operation



Cascade operation of VSD with two IF modules. For an equivalent flow-rate, the circulator automatically uses the lowest power curve. (E.g. VSD52-08 -  $D_p-c-H_n=2m$ ).

## ► Operating Functions at Constant $\Delta P$ or Variable $\Delta P$ Varistar 2 - VSS/VSD Single and Twin Circulator Units

### ► Functions

Symbol	Description of the various operating modes
Auto 	Normal operation: Authorisation for automatic changeover to low load mode. The activation of the low load mode occurs when the requirement for heating power is minimum (night configuration).
Auto 	The circulator operates in the low load mode (night decrease) with a minimum running speed.
Without symbol Auto	Interruption of automatic change over to low load mode i.e. the circulator only operates in the normal regulated mode.
H 9.0m	The differential set point pressure valve is set to H = 9.0m.
18.0 $\frac{\text{RPM}}{\text{X100}}$	The circulator is set to a constant running speed (in this case, 1800 rpm) (regulator mode).
	Setting $\Delta P$ -C: Adjustment to a constant set point differential pressure value.
	Setting $\Delta P$ -V: Adjustment to a constant set point differential pressure value.
	The operating mode regulator deactivates module adjustment. The running speed of the circulator is maintained at a constant value of between 800 and 2800 r.p.m. The speed of rotation is adjusted internally via the rotary knob.
 10V	With the regulator mode activated, the running speed of the circulator is set via input 0-10V. The rotary knob then has no set point indication function.
<b>On</b>	The circulator is on.
<b>Off</b>	The circulator is off.
	Cascade operation.
	For twin head version only (VSD).
	Normal/back-up operation.

### ► Liquid Crystal Display Panel

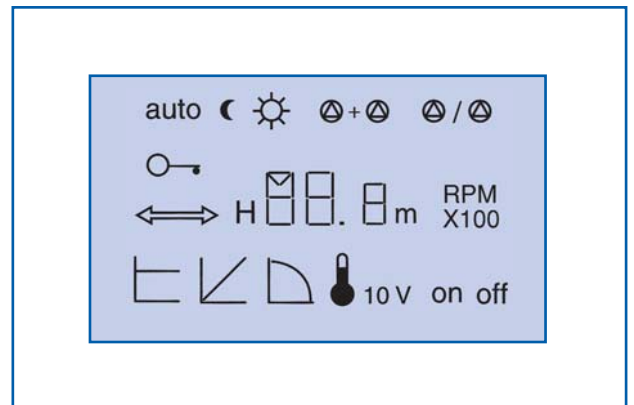

#### ► Functions:

- On/off.
- Constant  $\Delta P$ .
- Variable  $\Delta P$ .
- Manual Speed Adjustment.
- Automatic Idling (day/night).

#### ► Regulator Mode:

- Remote adjustment of speed (by 0-10V)

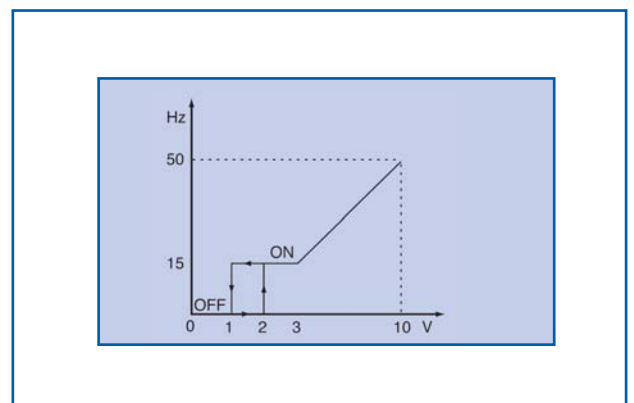

- Remote on/off.
- Fault transfer.

## Specification - VSS22-03, 32-05

### ► Design

- Casing with threaded connections for direct mounting on pipe.
- Rotating parts in contact with water made of corrosion proof material.
- Impeller neck wearing ring.

### ► Materials of Construction

- Circulator housing - Cast iron.
- Impeller - Composite material.
- Shaft - Stainless Steel.
- Bearings - Graphite.
- Impeller neck ring - Stainless steel.
- Seal - Ethylene propylene.

### ► Minimum Suction Head Required (mwg) versus operating temperature

Type	82°C	90°C	95°C
VSS22-03-1	1.5m	3.0m	10.0m
VSS32-05-1	1.5m	3.0m	10.0m

### ► Motor

- Single-phase, wet rotor.
- Bearings lubricated by circulator liquid.
- Self-regulating, adjusts to pressure needs of the installation.
- Self-protected by impedance, needs no external protection.

### ► Operating Limits

- Capacities up to 1.2 l/s
- Heads up to 50 kPa.
- Maximum working pressure 10 bar.
- Temperature range +20° to 95°C.
- Maximum ambient temperature + 40°C.
- Port ND. Screwed 25 (1") - 32 (1¼").

### ► Identification Plate

- Electronic module
- Single circulator
- Twin circulator (D)
- Nominal diameter of flange
- Discharge head in metres
- Phase

VSS 32 - 05 - 1

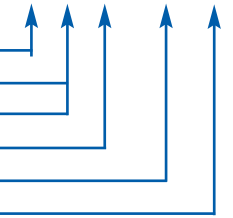

## Specification - VSS/VSD 42-10, 52-08, 52-11, 62-09, 82-12.

### ► Design

#### Circulator (Hydraulic End).

- Single or twin head flanged circulator.
- Tapped rear bosses for wall mounting.

### ► Materials of Construction VSS/VSD 42-82

- Circulator housing - Cast iron BS1452 grade 220.
- Impeller - Composite material.
- Shaft - AISI303 SS.
- Bearings - Carbon / metal.
- Seal - Ethylene propylene.

### ► Operating Limits VSS/VSD 42-82

- Capacities up to 18 l/s.
- Heads up to 100 kPa.
- Maximum working pressure 10 bar.
- Temperature range +20°C to 110°C.
- Maximum ambient temperature +40°C.
- Orifice ND. Flanged 40-50-65-80.

### ► Minimum Suction Head Required (mwg) Versus Operating Temperature

Type	70° C	90° C	110° C
VSS/VSD - 42	9.0m	13.0m	20.0m
VSS/VSD - 52	8.0m	12.0m	19.0m
VSS/VSD - 62	5.0m	9.0m	16.0m
VSS/VSD - 82	10.0m	14.0m	21.0m

### ► Motor

- Single phase 230v. wet rotor.
- Bearing shells lubricated by the circulator fluid.
- Motor protection incorporated by automatic stop on fault.
- Stainless steel lined rotor.
- Speed 850 - 2850 rpm.
- Single phase voltage 230V +/- 10%
- Frequency 50Hz.
- Insulation class F (155°C).
- Protection rating IP43.
- EMC conformity.
- Emissions EN 50 081.1
- Immunity EN 50 082.2

### ► Identification Plate

- Electronic module
- Single circulator
- Twin circulator (D)
- Nominal diameter of flange
- Number of poles in motor
- Discharge head in metres
- Phase

VS S 52 - 08 - 01

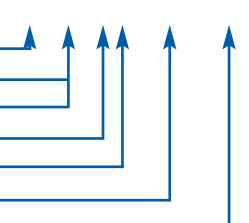

### ► Circulator Installations

#### VSS/VSD 42-10, 52-08, 52-11, 62-09, 82-12.

Circulators must always be installed with the shaft horizontal. Vertical shaft positioning is not allowed. Configurations shown on back cover are the only ones acceptable.

Our policy is one of continuous improvement and we reserve the right to alter our dimensions and specifications without notice

EXPERIENCE BUILDING...

Armstrong Integrated Limited  
Wenlock Way  
Manchester  
United Kingdom, M12 5JL  
T: +44 (0) 8444 145 145  
F: +44 (0) 8444 145 146

S. A. Armstrong Limited  
23 Bertrand Avenue  
Toronto, Ontario  
Canada, M1L 2P3  
T: 001 416 755 2291  
F: 001 416 759 9101

**ARMSTRONG** 