

ARMSTRONG



Close Coupled Vertical In-Line Pumps

FILE NO:	43.11IN
DATE:	Sep. 10, 2010
SUPERSEDES:	43.11IN
DATE:	July 20, 2009

► Typical Applications

- Cooling and heating systems.
- Pressure boosting systems.
- Industrial applications.

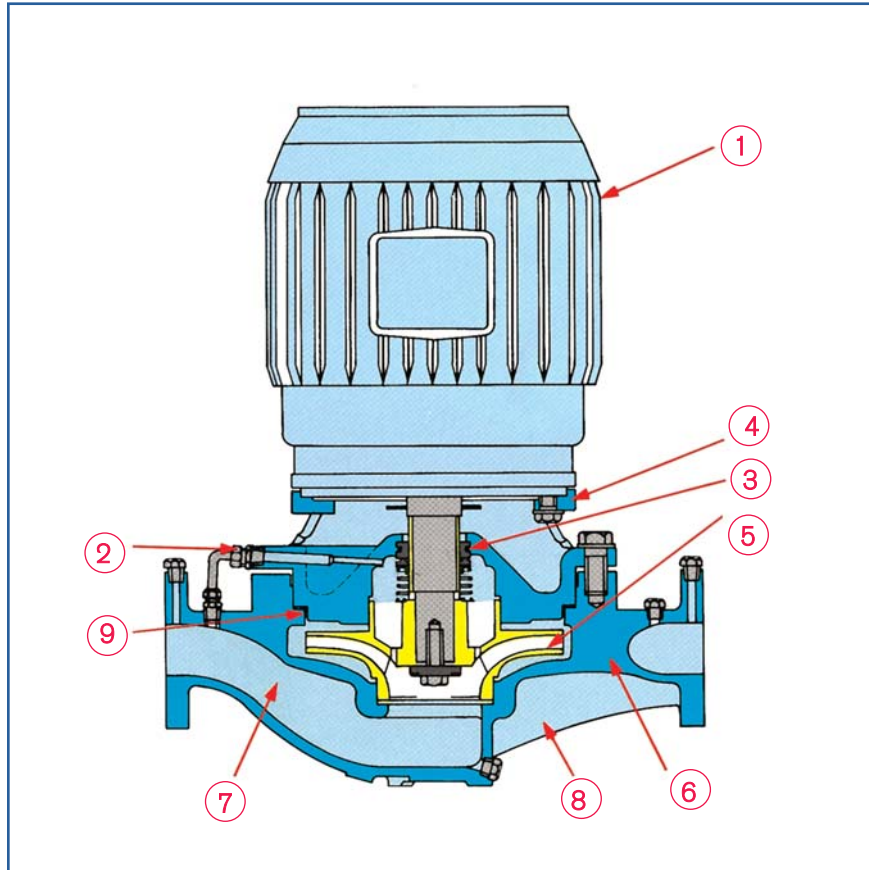

► Design Features

- ① Industry standard face mounted motor.
- ② Flush and vent connection removes entrained air and ensures liquid at seal face at all times.
- ③ Inside type mechanical seal serviceable without breaking pipe connections.
- ④ Heavy cylindrical bracket with 360° register on both flanges provides a rigid union of pump and motor.
- ⑤ Dynamically balanced impeller assures smooth vibration-free operation.
- ⑥ Radially split casing with equal suction and discharge flange sizes. Separate tapped openings for gauge, flush and drain connections.
- ⑦ Liberal inlet passageways and straightening vanes provide optimum suction performance and quiet operation.
- ⑧ Ribs cast integral with casing. Machined surface to accept floor support when specified.
- ⑨ Confined casing gasket to meet stringent industrial temperature and pressure applications.

► Materials of Construction

Pump Series	Flange Rating	Motor Frame	Construction	Casing	Impeller	Capscrew (Impeller)	Washer (Impeller)	Acorn Nut (Impeller)	Gasket (Casing)	Adapter Bracket	Motor Shaft	Shaft Sleeve	Stub Shaft	Shaft Spacer	Water Slinger	Seal Washer	Seal Seat	Seal Hardware	Seal Elastomer	Seal Spring	Companion Flanges
4380	PN16		BF	CI	BZ	SS-5	SS-3	-	F	CI	S	-	SS-3	SS-4	N	C	SiC	SS-2	EP	SS-5	-
	PN16	56c	AI	CI	CI	SS-5	SS-3	-	F	CI	S	-	SS-3	SS-4	N	C	SiC	SS-2	EP	SS-5	-
	PN16		AB	BZ	BZ	SS-5	SS-3	-	F	BZ	S	-	SS-3	SS-4	N	C	SiC	SS-2	EP	SS-5	-
	PN16		BF	CI	BZ	SS-5	SS-3	-	F	CI	S	BR-1	-	SS-4	N	C	SiC	SS-2	EP	SS-5	-
	PN16	JM/JP	AI	CI	CI	SS-5	SS-3	-	F	CI	S	SS-4	-	SS-4	N	C	SiC	SS-2	EP	SS-5	-
	PN16		AB	BZ	BZ	SS-5	SS-3	-	F	BZ	S	BR-1	-	SS-4	N	C	SiC	SS-2	EP	SS-5	-
	PN25	JM/JP	DBF	DI	BZ	SS-5	SS-3	-	F	DI	S	BR-1	-	SS-4	N	C	SiC	SS-2	EP	SS-5	-
	PN25		DI	DI	CI	SS-5	SS-3	-	F	DI	S	SS-4	-	SS-4	N	C	SiC	SS-2	EP	SS-5	-

Materials of Construction Code

BF	-	Bronze Fitted	BZ	-	Cast Bronze ASTM B584 Grade C84400	DI	-	Cast Ductile Iron ASTM A536 Grade 65-45-12	SiC	-	Silicone Carbide
AI	-	All Iron	BR-1	-	Hard Brass Tubing ASTM B111.687	EP	-	EPDM elastomer	SS-2	-	ASTM A564 Type 18-8
AB	-	All Bronze	CI	-	Cast Iron ASTM A48 Class 30	F	-	Fiber	SS-3	-	ASTM A314 Type 303
DBF	-	Bronze Fitted, Ductile Casing and Adapter Bracket	N	-	Neoprene	SS-4	-	ASTM A276 Type 304	SS-5	-	AISI 1010-1018 Type 316
DI	-	All Iron, Ductile Casing and Adapter Bracket	S	-	Carbon Steel						

► Pressure/Temperature Parameters*

- Cast Iron - PN16 flanges
Pressure up to 16 bar (232 PSI)
Temperature upto 107°C (225°F)
- Ductile Iron - PN25 flanges
Pressure up to 17 bar (250 PSI)
Temperature upto 121°C (250°F)

*Please view AceOnline or submittal data for full details

Notes:

- Hydrostatic test pressure at ambient temperature is 150% maximum working pressure.
- All values are based on clear, clean water. Values may change with other liquids.

► Typical Specifications

1.0 PUMPS - CLOSE COUPLED VERTICAL IN-LINE.

2.0 Provide Armstrong single stage, single suction Vertical In-Line type pumps, with rising head to shut off pump characteristics.

Refer to the schedule for pump flows and heads and motor speed, efficiency, enclosure and power requirements.

3.0 The pumps shall be Armstrong Series 4380 motor mounted Vertical In-Line.

4.0 Pump Construction:

4.1 Pump casing shall be cast iron, suitable for 16 bar (232 PSI) working pressure. Ductile iron pump casings are suitable for pressures to 17 bar (250 PSI). The casing shall be hydrostatically tested to 150% maximum working pressure.

The casing shall be radially split to allow removal of the rotating element without disturbing the pipe connections.

The casing suction and discharge connections shall be the same size and shall be provided with drilled and tapped seal vent and pressure gauge connections.

4.2 Pump impeller shall be bronze, fully enclosed type. Impeller shall be dynamically balanced.

4.3 A bronze shaft sleeve, extending the full length of the mechanical seal area, shall be provided.

4.4 Mechanical seal shall be single spring inside type with carbon against silicone carbide faces. EPDM elastomer with stainless steel spring and hardware shall be provided. Seal vent line shall be factory installed and shall be piped from the seal area to the pump suction connection.

5.0 Motor power requirements shown on the pump schedule are the minimum acceptable and have been sized for continuous operation without exceeding the full load nameplate rating over the entire pump curve, exclusive of service factor.

Other Armstrong Products

For even greater space savings, ease of installation and flexibility of use:

Specify Armstrong **dualARM** Vertical In-Line pump.

- Two (2) Armstrong time proven Vertical In-Line pumps in one (1) casing.
- Eliminates a complete set of piping and fittings.
- Stand-by or two pump parallel operation with no loss of single pump efficiency.
- Remove one pump for repair while the second pump continues to operate.

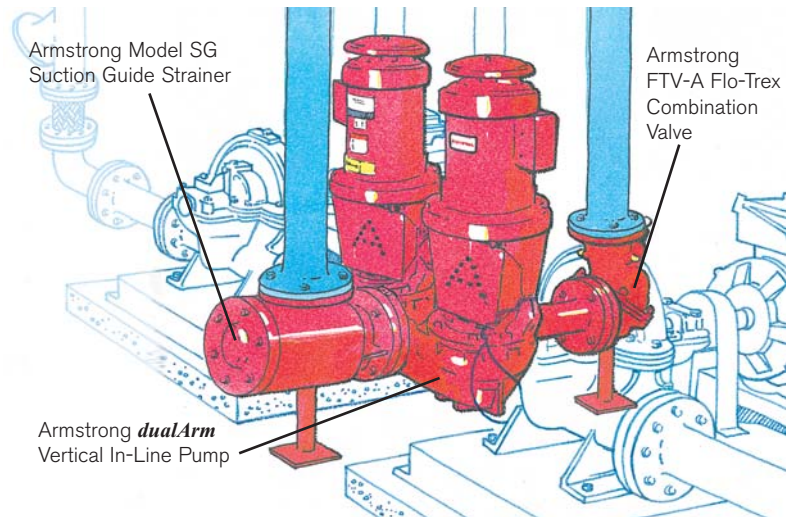

S. A. Armstrong Limited
23 Bertrand Avenue
Toronto, Ontario
Canada, M1L 2P3
T: (416) 755-2291
F (Main): (416) 759-9101

Armstrong Integrated Limited
Wenlock Way
Manchester
United Kingdom, M12 5JL
T: +44 (0) 8444 145 145
F: +44 (0) 8444 145 146

Armstrong Design Private Ltd.
(Unit 1- Armstrong Manufacturing Center)
490-L, 4th Phase, Peenya Industrial Area,
Bangalore, India 560 058
T: +91 (80) 4149 2832
F: +91 (80) 4149 2831



© S.A. Armstrong Limited 2010