

# ARMSTRONG

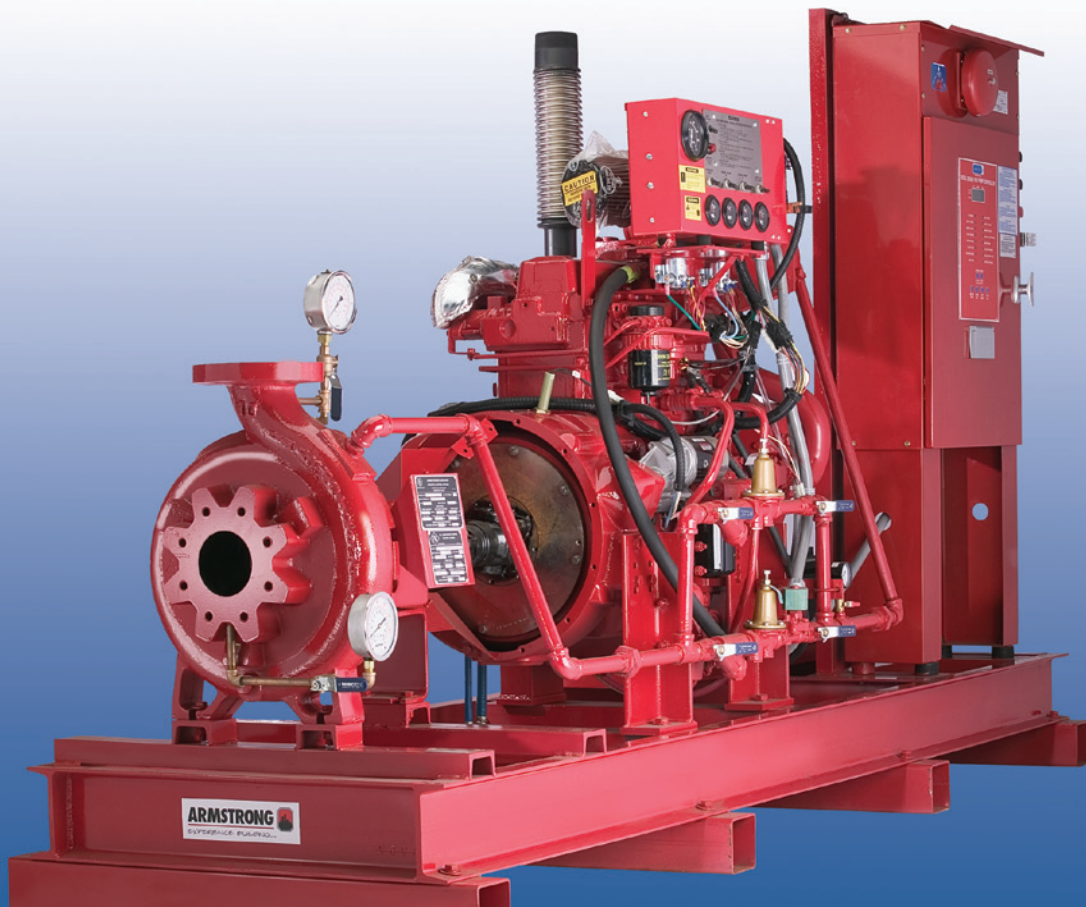

## End Suction Fire Pumps & Packaged Systems

FILE NO:	F43.40
DATE:	Sept. 17, 2010
SUPERSEDES:	F43.40
DATE:	May 26, 2008

# Armstrong Pumps, Hallmark of Quality

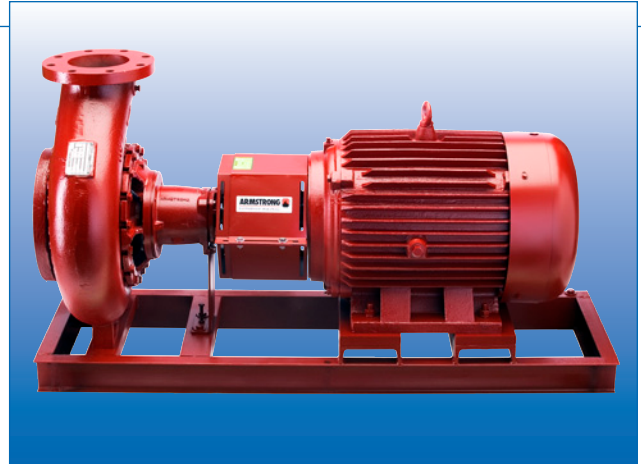

**Armstrong series 40MF end suction fire pump is the perfect solution for small capacity diesel driven fire applications. It offers all the well known features of Armstrong Quality products.**

## ► Design Features

- Ideal for flows from 250 USgpm to 1750 USgpm
- Compact diesel package
- More economical than HSC diesel packages
- Back pullout design for easy maintenance
- Self venting centerline discharge
- Low NPSH requirements
- One-piece baseplate
- UL listed coupling for all electric units
- OSHA coupling guard
- Drain and gauge connections
- Ductile iron, bronze-fitted construction
- 2-Plane dynamically balanced impeller

## ► 40MF Horizontal End Suction Fire Pumps

FLOW (USgpm)	50Hz HEAD (psi)	60Hz HEAD (psi)	Diesel HEAD (psi)
250	45 - 92	57 - 136	42 - 96
300	44 - 212	55 - 135	41 - 122
400	49 - 211	45 - 132	45 - 220
450	60 - 206	41 - 130	41 - 218
500	101 - 207	40 - 177	40 - 215
750	102 - 190	40 - 172	41 - 200
1000	98 - 168	145 - 163	55 - 168
1250	87 - 162	---	54 - 162
1500	112 - 152	---	83 - 152
1750	---	---	106 - 147

The pump is rated for fire at various diesel speeds such as 2100 RPM, 2350 RPM, 2600 RPM and 3000 RPM. Contact your local representative for all the details.

# Base Mounted Centrifugal End Suction Fire Pump

## Pump Casing

- ▶ Top centerline discharge, self venting to eliminate vapor lock
- ▶ Designed to withstand the high pressure requirements typical in Fire Protection applications
- ▶ Radial split design allows removal of bearing assembly and impeller without disturbing pipe connection

## Flanges

- ▶ ANSI and PN available

## Gauge Connection

- ▶ Drilled and tapped for discharge gauge connection

## Coupling

- ▶ UL Listed half spacer coupling on all Electric units
- ▶ Flexible connecting shaft on all Diesel units
- ▶ OSHA coupling guard provided on all pumping units

## Bearing Assembly

- ▶ Regreaseable bearings carry design loads

## Impeller

- ▶ Dynamically balanced cast bronze

## Packed Gland Seal

- ▶ Graphite packing
- ▶ Teflon lantern ring

## Casing Drain

- ▶ Drilled and tapped connection for drain

## Baseplate

- ▶ Heavy fabricated steel baseplate, rigidly constructed to provide proper alignment of pump and motor

## Drip Containment

- ▶ Fitted with drain connection

## Pump Base

- ▶ Base supported casing eliminates need to support casing when bearing assembly is removed

## Shaft Sleeve

- ▶ Replaceable stainless steel sleeves
- ▶ Protect shaft through stuffing box

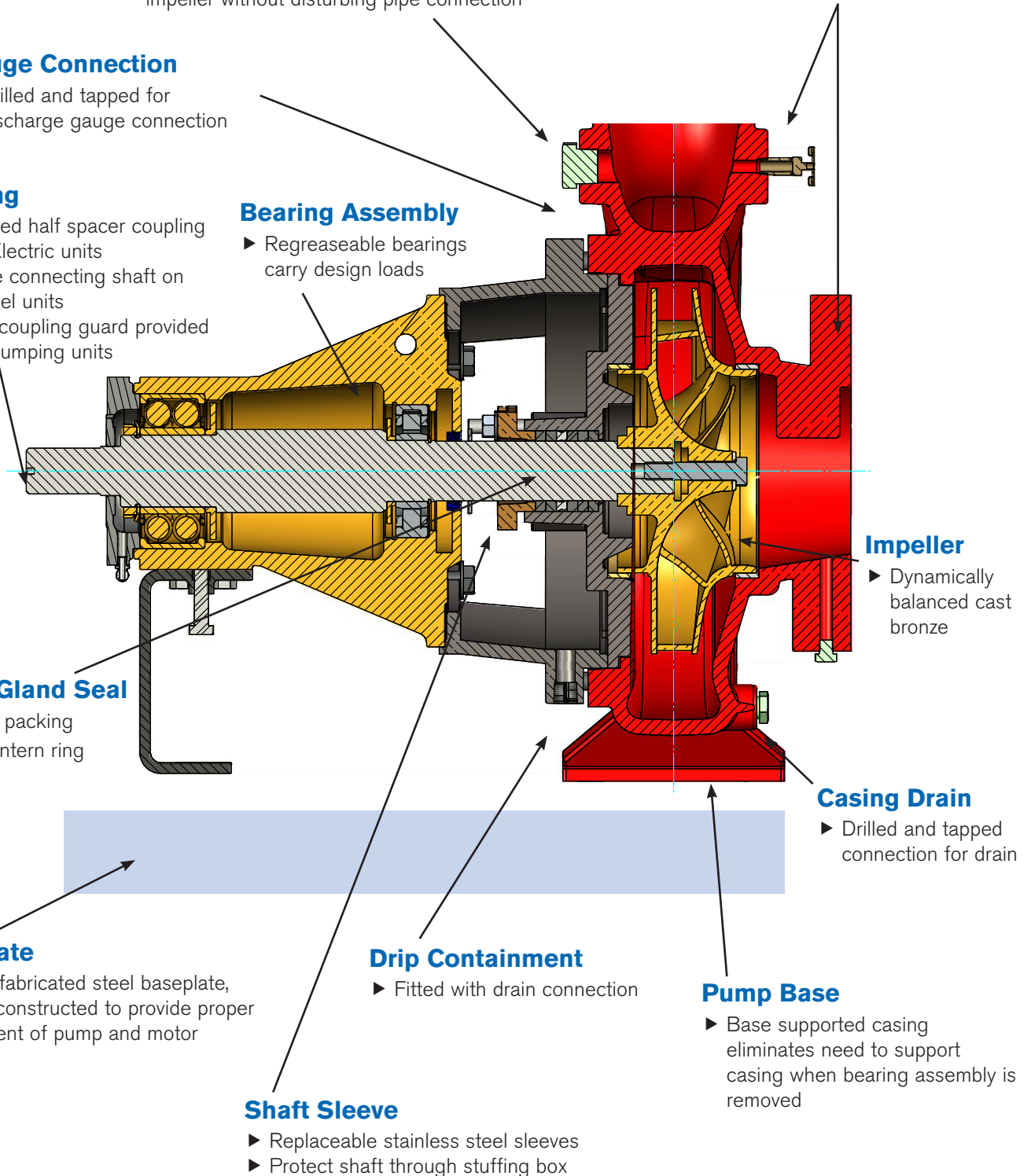

## ► Typical Specifications

# End Suction Fire Pump - Electric Motor Driven\*

Supply and install as indicated on plans one (1) fire pump system consisting of:

### 1. FIRE PUMP

One Armstrong, SERIES 40MF, Size \_\_\_\_\_ end suction fire pump listed by [Underwriters Laboratories of Canada (ULC)], [Underwriters Laboratories Inc. (UL)] and/or [approved by Factory Mutual (FM)] having a capacity of \_\_\_\_\_ USGPM for a pressure boost of \_\_\_\_\_ PSIG. Suction pressure \_\_\_\_\_ PSIG.

Pump casing shall be radially split, top centerline discharge, self venting casing. The pump construction shall be ductile iron, bronze fitted and shall be fitted with packing. The shaft shall be fitted with stainless steel sleeve and be supported by two back to back thrust ball-bearings and one radial roller bearing. The back pullout design shall allow the complete rotating assembly to be removed without disturbing the casing piping connections.

Each stuffing box shall be fitted with a three-piece bronze gland. Stuffing box shall be fitted with a stuffing box extension to facilitate the packing rings removal. Packing rings shall be removable without disturbing wetted parts or the pump bearings. Water seal rings made from non-corroding material shall be piped to pump volute.

### 2. ELECTRIC MOTOR

The fire pump shall be directly coupled through a UL Listed half-spacer coupling to a horizontal electric motor with a maximum HP of \_\_\_\_\_ at \_\_\_\_\_ RPM, \_\_\_\_\_ VOLT, \_\_\_\_\_ PHASE \_\_\_\_\_ CYCLE. Motor shall be UL Listed for fire pump service, open drip proof, standard efficiency with 1.15 service factor.

### 3. MINIMUM FITTINGS

The pump shall be supplied with the following accessories:

- One (1) combination suction gauge 3½" dial type with ¼" cock and lever handle.
- One (1) discharge gauge, 3½" dial type, with ¼" cock and lever handle.
- One (1) casing pressure relief valve.

### 4. OTHER ACCESSORIES

Pump shall be fitted with one (1) eccentric suction reducer and one (1) concentric discharge increaser, as required (by mechanical contractor) to fit NFPA20 recommended piping sizes.

One (1) outside test header shall be supplied with one (1) set of \_\_\_\_ x 2½" hose valves with caps and chains.

### 5. FIRE PUMP CONTROLLER

The fire pump controller shall be specifically approved for fire pump service by [ULC], [UL] and/or [FM]. The controller shall be of the combined manual and automatic stop, \_\_\_\_\_ starting method, Model \_\_\_\_\_

as manufactured by \_\_\_\_\_. All equipment shall be enclosed in an approved drip proof enclosure. The control equipment shall be completely assembled, wired and tested at point of manufacture prior to shipment.

Circuit breaker shall have an interrupting capacity of \_\_\_\_\_ kAmps or a withstand rating of \_\_\_\_\_ kAmps RMS.

### 5A. FIRE PUMP CONTROLLER AND AUTOMATIC TRANSFER SWITCH COMBINATION

The automatic transfer switch controller combination shall be approved by [UL], [ULC] and/or [FM], Model \_\_\_\_\_ as manufactured by \_\_\_\_\_. The automatic transfer switch and the pump controller shall each be mounted in separate enclosure, mechanically attached to form one unit and provide for protected interlock wiring.

The automatic transfer switch shall be capable of automatic power transfer from normal to alternate \_\_\_\_\_ second utility emergency power source in case of normal supply failure and automatically re-transfer after restoration of normal power conditions.

### 6. JOCKEY PUMP

The jockey pump shall be a vertical multi-stage by Armstrong, Model No. \_\_\_\_\_ for a capacity of \_\_\_\_\_ USGPM and a pressure boost of \_\_\_\_\_ PSIG. The jockey pump shall be driven by an [open drip proof] [totally enclosed fan cooled] electric motor of \_\_\_\_\_ HP \_\_\_\_\_ RPM \_\_\_\_\_ VOLT \_\_\_\_\_ PHASE \_\_\_\_\_ CYCLE.

### 7. JOCKEY PUMP CONTROLLER

The jockey pump shall be controlled by an automatic jockey pump controller model \_\_\_\_\_ as manufactured by \_\_\_\_\_ with full voltage starter.

### 8. MOUNTING AND TESTING

The fire pump shall be hydrostatically tested at twice the maximum working pressure for at least 5 minutes. The fire pump shall be performance tested at rated speed. The fire pump shall furnish remove less than 150% of rated capacity at a pressure not less than 65% of rated head. The shut-off total head of the fire pump should not exceed 140% of total rated head. A certified test curve, indicating the flow, head, power and efficiency shall be supplied for the field acceptance test. The fire pump and electric motor shall be base mounted and aligned at the pump manufacturer's factory. Final alignment shall be made after installation on site.

\* Please refer to Armstrong Fire Pump Catalogue for Diesel Driven Typical Specifications.

EXPERIENCE BUILDING...

S. A. Armstrong Limited  
23 Bertrand Avenue  
Toronto, Ontario  
Canada, M1L 2P3  
T: (416) 755-2291  
F (Main): (416) 759-9101

Armstrong Pumps Inc.  
93 East Avenue  
North Tonawanda, New York  
U.S.A., 14120-6594  
T: (716) 693-8813  
F: (716) 693-8970

Armstrong Integrated Limited  
Wenlock Way  
Manchester  
United Kingdom, M12 5JL  
T: +44 (0) 8444 145 145  
F: +44 (0) 8444 145 146



© S.A. Armstrong Limited 2010

For Armstrong locations worldwide, please visit [www.armstrongintegrated.com](http://www.armstrongintegrated.com)