

INSTALLATION AND OPERATING INSTRUCTIONS

COMMERCIAL PUMPS Series 4030 Base Mounted Pumps

CE CONFORMITIES

For declaration of Conformities, contact Armstrong.

INTRODUCTION

This document contains specific information regarding the safe installation, operating and maintenance of the Series 4030 pumps and should be read and understood by installing, operating and maintenance personnel. The equipment supplied has been designed and constructed to be safe and without risk to health and safety when properly installed, operated and maintained. The instructions following must be strictly adhered to. If clarification is needed on any point please contact Armstrong quoting the equipment serial number.

WARNING SYMBOLS



Safety instruction where an electrical hazard is involved.



Safety instruction where non-compliance would affect safety risk.



Safety instruction relating to safe operation of the equipment. (ATTENTION)

INSTRUCTIONS FOR SAFE USE

No installation of this equipment should take place unless this document has been studied and understood. Handling, transportation and installation of this equipment should only undertaken by trained personnel with proper use of lifting equipment. See later diagrams for lifting advice. Refer to the pump nameplate for pump speed, pressure and temperature limitations. The limits stated must not be exceeded without written permission from Armstrong.

TEMPERATURE

Where under normal operating conditions the limit of 68°C/155°F (Restricted Zone) for normal touch, or 80°C/176°F (Unrestricted Zone) for unintentional touch, may be experienced, steps should be taken to minimize contact or warn operators/users that normal operating conditions will be exceeded. In certain cases where the temperature of the pumped liquid exceeds the above stated temperature levels, pump casing temperatures may exceed 100°C/212°F and not withstanding pump insulation techniques appropriate measures must be taken to minimize risk for operating personnel.

NOISE LEVELS

For Pumping Unit Sound Pressure Levels, see Motor Technical Data sheet (File No. 48.11L).

STORAGE

Pumps not immediately placed into service, or removed from service and stored, must be properly prepared to prevent excessive rusting. Pump port protection plates must not be removed until the pump is ready to connect to the piping. Rotate the shaft periodically (At least monthly) to keep rotating element free and bearings fully functional. For long-term storage, the pump must be placed in a vertical position in a dry environment. Internal rusting can be prevented by removing the plugs at the top and bottom of the casing and drain or air blow out all water to prevent rust buildup or the possibility of freezing. Be sure to reinstall the plugs when the unit is made operational. Rust proofing or packing the casing with moisture absorbing material and covering the flanges is acceptable. When returning to service be sure to remove the drying agent from the pump.

UNCRATING

Armstrong End Suction pumps are thoroughly inspected before shipment to assure they meet with your order requirements. After removing the pump from the crate, make sure the equipment is in good order and that all components are received as called for on the packing list. Any shortages or damage should be reported immediately. Use extreme care in handling the unit, placing slings and hooks carefully so that stress will not be imposed on the pump. NEVER PLACE CABLE SLINGS AROUND THE PUMP SHAFT. The eye bolts or lifting lugs on the motor are intended for lifting only the motor and not the complete unit.

HANDLING

Use slings as shown in the diagram to lift the set. Do not use the motor eyebolts to lift the pump set. See the delivery note for the weight of the set.

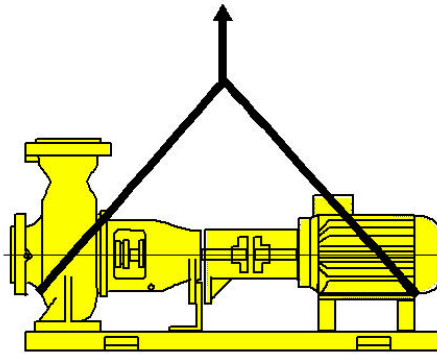

LIMITATIONS

See pump nameplate for speed, duty and maximum pressure/temperature limitations. These limits must not, under any circumstances be exceeded without prior consultation with Armstrong.

IMPORTANT:

Do not run the pump for any length of time under very low flow conditions or with the discharge valve closed. To do so could cause the water in the casing to reach super heated steam conditions and will cause premature failure and could cause serious and dramatic damage to the pump and surrounding area.

INSTALLATION

1. LOCATION

- In open systems, locate the unit as close as practical to the liquid being pumped, with a short, direct suction pipe. Ensure adequate space is left above and around the unit for operation, maintenance, service and inspection of parts
- In closed systems, where possible, the pumps should be installed immediately downstream of the expansion tank/make-up connection. This is the point of zero pressure change and is necessary for effective pump operation. Do not install more than one expansion tank connection into any closed hydronic system
- Electric motor driven pumps should not be located in damp or dusty location without special protection
- Airflow into the motor and/or motor fan should not be obstructed

2. INSTALLATION

- Recommended installation arrangements are:

2.1 FOUNDATION

The foundation should be sufficiently substantial to absorb any vibration and to form a permanent rigid support for the baseplate. This is essential in maintaining the alignment of a direct connected unit. A good foundation should weigh approx. 2.5 times the shipping weight of the pump. In building the foundation, make ample allowance for grouting. Foundation bolts of the proper size should be arranged as shown, with a pipe sleeve embedded in the concrete to permit adjustment of the bolts after the concrete has been poured. Use sleeves with a diameter 2.5 times the diameter of the bolts.

Locate the pump on its foundation holes using the motor feet as a template.

Drill four holes of the required size and insert the anchors.

Take the tamping tool (supplied with the anchors) and drive home the lead sleeve until it is below the level of the foundation and firmly fixed in the concrete.

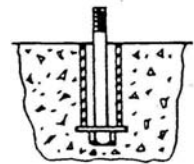

2.2 LEVELLING

When the unit has been placed on its foundation, slacken off the coupling setscrews and slide back the coupling halves so that the pump and motor shafts are free to rotate independently. Re-tighten the setscrews in this position. Do not re-connect the coupling until after the unit has been piped up, finally aligned and checked for correct direction of rotation.

Insert metal wedges approx. 15mm thick on either side of the foundation bolts under the baseplate as shown. Adjust wedges until the shafts of the pump and motor are level. On flanged pumps check suction and discharge flanges for vertical or horizontal position using a level and correct as necessary by adjusting the wedges. When the baseplate is completely level, the foundation bolts should be tightened evenly and firmly. Do not over-tighten bolts at this stage.

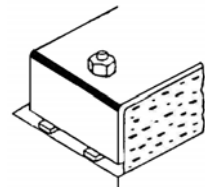

2.3 ALIGNMENT

The pump unit is accurately aligned in our factory prior to being shipped. However all baseplates are flexible to some extent and must not be relied upon to maintain factory alignment. Re-alignment is necessary as follows:

- After the unit has been set level on its foundation
- After the grout has set and the foundation bolts have been tightened
- After the pipes have been connected

Accurate alignment is absolutely essential, proper mechanical operation of the equipment cannot be guaranteed unless the factory alignment is reproduced in the field.

Coupling Alignment

Check the alignment by placing a straight edge across the coupling rims at the top, bottom and both sides. Care must be taken to have the straight edge parallel to the axis of the pump and motor shaft. Alignment is obtained when the straight edge rests evenly on both rims in all four positions.

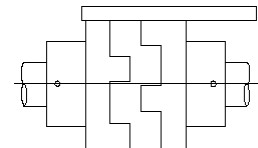

Adjust as necessary by placing shims under the motor feet.

2.4 GROUTING

After levelling the unit and checking the alignment. Fill the baseplate completely with grout, allowing it to flow around the wedges under the baseplate. Allow 48 hours for the grout to harden before final tightening of the foundation bolts.

2.5 PIPING

Both the suction and discharge pipes should be independently supported near the pump so that no strain is imposed on the pump when the pipes are connected. All connecting pipework should be accurately located – do not attempt to force the suction and discharge pipes into position.

Suction Piping

Use short direct suction piping one or two times larger than the pump suction nozzle. Arrange piping to eliminate potential air pockets and use an eccentric reducer to connect to the suction nozzle. A strainer three or four times the area of the suction pipe will prevent foreign materials entering the pump.

Discharge Piping

A check valve and gate valve should be installed in the discharge line. If an increaser is used on the discharge side to increase the size of the discharge pipe it should be placed between the check valve and the pump.

2.6 FINAL ALIGNMENT

When the piping has been connected, check the alignment and make corrections if necessary. Energise the motor (with coupling halves disconnected) and check that the rotation corresponds with the direction arrow on the pump to reverse the rotation on a three-phase motor, interchange two leads.

When rotation and alignment are correct, re-connect the coupling with both halves butting against the rubber insert. Tighten the coupling set screws.

3. PUMP PIPING - GENERAL

- Never connect a pump to piping, unless extra care is taken to measure and align the piping flanges well. Always start piping from pump. Use as few bends as possible and preferably long radius elbows.
- Ensure the piping exerts no strain on the pump as this could distort the casing causing breakage or early failure due to pump misalignment.
- All connecting pipe flanges must be square to the pipework and parallel to the pump flanges.
- Suction and discharge pipes may be increased or decreased at the pump nozzle to suit pump capacity and particular conditions of installation. Use eccentric reducers on suction connection with flat side uppermost.
- Layout the suction line with a continual rise towards the pump without high points, thus eliminating possibility of air pockets that may prevent the pump from operating effectively.
- A strainer of three or four times the area of the suction pipe, installed in the suction line, will prevent the entrance of foreign materials into the pump. 5mm diameter perforations in the strainer is typical.
- In open systems, test suction line for air leaks before starting; this becomes essential with long suction line or static lift.
- Install, at the pump suction, a straight pipe of a length equivalent to 4 or 6 times its diameter; this becomes essential when handling liquids above 49°C (120°F). Armstrong suction guides may be used in place of the straight pipe run and in-line strainer.
- Install an isolation valve in both suction and discharge lines on flooded suction application; these valves are used primarily to isolate the pump for inspection or repair
- Install a non-slam non-return check valve in discharge line between pump and isolation valve to protect pump from excessive back pressure and to prevent water running back through the pump in case of driver failure on open systems. An Armstrong Flo-Trex valve may be used in place of non-return check valve and isolation valve on pump discharge.

CAUTION:



The discharge valve only is to be used to throttle pump flow, not the suction valve. Care must be taken in the suction line layout and installation, as it is usually the major source of concern in centrifugal pump applications.

OPERATION

4. STARTING PUMP

- Ensure that the pump turns freely by hand, or with some mechanical help such as a strap and lever on larger pumps. Ensure that all protective guarding is securely fixed in position.
- The pump must be fully primed on start up. Fill the pump casing with liquid and rotate the shaft by hand to remove any air trapped in the impeller.
- “Bump” or energize the motor momentarily and check that the rotation corresponds with the directional arrow on the pump casing.
- To reverse rotation of a three-phase motor, interchange any two power leads.
- Start the pump with the discharge valve closed and the suction valve open, then gradually open the discharge valve when the motor is at operating speed. The discharge valve may be “cracked” or open slightly at start up to help eliminate trapped air.
- When stopping the pump: Close the discharge valve and de-energize the motor.
- DO NOT run the pump against a closed discharge valve for an extended period of time. (A few minutes maximum)
- Star-Delta motor starters should be fitted with electronic/mechanical interlocks that have a timed period of no more than 40 milli-seconds when switching from star (Starting) to delta (Run) connection yet allow the motor to reach full star (Starting) speed before switching to delta (Run).
- Should the pump be noisy or vibrate on start-up a common reason is overstated system head. Check this by calculating the pump operating head by deducting the suction pressure gauge value from the discharge gauge reading. Convert the result into the units of the pump head as stated on the pump nameplate and compare the values. Should the actual pump operating head be significantly less than the nameplate head value it is typically permissible to throttle the discharge isolation valve until the actual operating head is equal to the nameplate value. Any noise or vibration usually disappears. The system designer or operator should be made aware of this soon as some adjustment may be required to the pump impeller diameter or drive settings, if applicable, to make the pump suitable for the system as installed.

CAUTION

Check the direction of rotation against the rotation arrow prior to operating the unit.

5. GENERAL CARE

- Series 4030 pumps are built to operate without periodic maintenance, other than bearing lubrication on some units. A systematic inspection made at regular intervals will ensure years of trouble-free operation, give special attention to the following:
- Keep the unit clean
- Provide the motor with correctly sized overload protection
- Keep moisture, refuse, dust or other loose particles away from the pump and ventilating openings of the motor
- Avoid operating the unit in overheated surroundings (Above 40°C/100°F).

WARNING

Whenever any service work is to be performed on a pumping unit, disconnect the power source to the driver, LOCK it OFF and tag with the reason. Any possibility of the unit starting while being serviced must be eliminated.

- If mechanical seal environmental accessories are installed, ensure water is flowing through the sight flow indicator and that filter cartridges are replaced as recommended. (See Armstrong files 43.85 & 43.86 for seal environmental instructions).

CAUTION

Under no circumstances should the pump be used for flushing out the system. In line with CIBSE commissioning code W: 1994, the pump should be out of line or bypassed during flushing.

6. LUBRICATION

Pump

Sealed Grease Bearings

- If the pump is fitted with greased lubricated bearings, no external lubrication is required.
- These bearings are custom greased for general service applications and sealed.

Oil Lubricated Bearings

- If the pump is fitted with oil lubricated bearings; use a non-detergent oil equal to No.10 motor oil.
- Prior to start up check to make sure the oil level is visible in the sight glass.
- Under normal operating conditions the oil should be changed every year or 3000 hours as follows:
 - a) Drain the oil from the old bearing bracket.
 - b) Thoroughly flush the bearing bracket with Kerosene.
 - c) Refill the oil through the vent on top of the bracket until the oil level is visible in the middle of the sight glass.

Motor

- Follow the lubrication procedures recommended by the motor manufacturer. Many small and medium sized motors are permanently lubricated and need no added lubrication. Generally if there are grease fittings evident the motor needs periodic lubrication. None if not.
- Check the lubrication instructions supplied with the motor for the particular frame size indicated on the motor nameplate.

Mechanical Seal

- Mechanical seals require no special attention. If leakage occurs investigate the cause and replace the seal following the makers recommendations, then realign the pump and motor shafts.
- Do not run the pump unless properly filled with water as the mechanical seals need a film of liquid between the faces for proper operation.
- Mechanical seals may 'weep' slightly at start-up. Allow the pump to continue operating for several hours and the mechanical seal to 'seat' properly prior to calling for service personnel.

7. SYSTEM CLEANLINESS

- Before starting the pump the system must be thoroughly cleaned, flushed and drained and replenished with clean liquid.
- Welding slag and other foreign materials, "Stop Leak" and cleaning compounds and improper or excessive water treatment are all detrimental to the pump internals and sealing arrangement.
- Proper operation cannot be guaranteed if the above conditions are not adhered to.

CAUTION:



Under no circumstances should the pump be used for flushing out the system. In line with CIBSE commissioning code W: 1994, the pump should be out of line or bypassed during flushing.

NOTE:

Particular care must be taken to check the following before the pump is put into operation:

- a) Pump primed?
- b) Rotation OK?
- c) Lubrication OK?
- d) Pipework properly supported?
- e) Voltage supply OK?
- f) Overload protection OK?
- g) Is the system clean?
- h) Is the area around the pump clean?

WARRANTY

Does not cover any damages to the equipment resulting from failure to observe the above precautions. Refer to Armstrong General Terms and Warranty sheet. Contact your local Armstrong representative for full information.

Symptoms	Reasons
<i>Pump Fails To deliver</i>	<ul style="list-style-type: none"> • Pump not primed. • Suction line not filled. • Air or vapour pocket in suction line. • Inlet of Suction pipe insufficiently submerged. • N.P.S.H. available too low. • Suction lift too high. • Air leaks in suction line, gland or pump joints. • Blocked suction. • Incorrect rotation. • Speed too low. • Total head of system higher than that of pump.
<i>Pump vibrates</i>	<ul style="list-style-type: none"> • Misalignment. • Air or vapour pocket in suction line. • Inlet of suction pipe insufficiently submerged. • N.P.S.H. available too low. Suction lift too high. • Blocked suction. • Impeller damaged. • Packing too tight. • Misalignment of pipework. • Operation at low capacity. • Rotating element out of balance. • Shaft bent. • Poor foundations.
<i>Seal leaks or fails</i>	<ul style="list-style-type: none"> • Misalignment. • Impurities in water. • Entrained air. • Cavitation. • Bearing failure. • Water treatment not allowed for.
<i>Low delivery rate</i>	<ul style="list-style-type: none"> • Air or vapour pocket in suction line. • Inlet of suction pipe insufficiently submerged. • N.P.S.H. available too low. • Suction lift too high. • Air leaks in suction line, gland or pump joints. • Blocked suction. • Incorrect rotation. • Speed too low. • Excessive system friction. • Impeller damaged
<i>Insufficient pressure</i>	<ul style="list-style-type: none"> • Incorrect rotation. • Speed too low. • Excessive system friction. • Impeller damaged.
<i>Low bearing life</i>	<ul style="list-style-type: none"> • Misalignment. • Dirt in bearings. • Bearings too tight. • Bearings badly installed. • Misalignment of pipework. • Rotating element out of balance. • Shaft bent.
<i>Bearings overheat</i>	<ul style="list-style-type: none"> • Misalignment. • Insufficient cooling to stuffing box. • Badly packed stuffing box. • Misalignment of pipework. • Dirt in bearings. • Bearings too tight. • Bearings badly installed.
<i>Stuffing box overheats</i>	<ul style="list-style-type: none"> • Packing too tight. • Insufficient cooling to stuffing box. • Badly packed stuffing box. • Misalignment of pipework.
<i>Pump delivery fails after start</i>	<ul style="list-style-type: none"> • Suction line not filled. • Air or vapour pocket in suction line. • Inlet of suction pipe insufficiently submerged. • N.P.S.H. available too low. • Suction lift too high. • Air leaks in suction line, gland or pump joints. • Blocked suction. • Impeller damaged.

Symptoms	Reasons
Pump seized	<ul style="list-style-type: none"> • Pump not primed. • Misalignment of pipework. • Operation at low capacity
Pump does not prime	<ul style="list-style-type: none"> • Pump not primed. • Inlet of suction pipe insufficiently submerged. • Suction lift too high. • Blocked suction. • Incorrect rotation. • Badly packed stuffing box
Pump Noisy	<ul style="list-style-type: none"> • Misalignment. • Air or vapour in suction line. • Inlet or suction pipe insufficiently submerged. • N.P.S.H. available too low. • Air leaks in suction line, gland or pump joints. • Blocked suction. • Impeller damaged. • Operation at low capacity. • Rotating element out of balance. • Shaft bent. • Poor foundations. • Packing too tight. • Operation at high capacity.
Motor overloading	<ul style="list-style-type: none"> • Misalignment. • Speed too high. • Low system friction. • Pumped liquid density is greater than anticipated. • Packing too tight.
Motor overheating	<ul style="list-style-type: none"> • Misalignment. • Speed too high. • Low system friction. • Pumped liquid density is greater than anticipated. • Packing too tight.

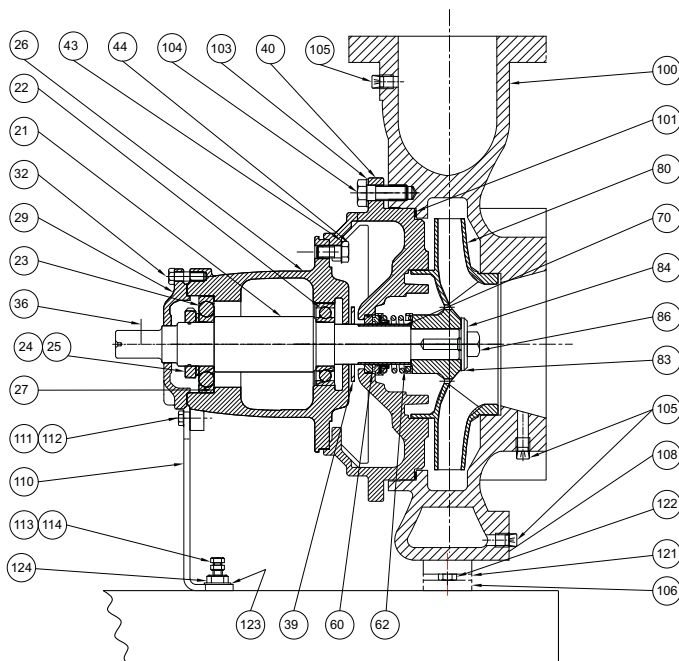

ITEM DESCRIPTION

21	Shaft	84	Lockwasher (when fitted)
22	Bearing (Inboard)	86	Capscrew Hex Hd.
23	Bearing (Outboard)	100	Casing
24	Lockwasher	101	Gasket
25	Lock Nut	103	Washer
26	Bearing Housing	104	Capscrew Hex Hd.
27	Snap Ring	105	Pipe plug
29	Cap (O/B)	106	Support foot
32	Capscrew Hex Hd.	108	Capscrew
36	Key Woodruff	110	Support foot (casing)
39	Water Slinger	111	Washer
40	Adapter	112	Capscrew Hex Hd.
43	Washer	113	Nut jam (when fitted)
44	Capscrew Hex Hd.	114	Capscrew (when fitted)
60	Seat	121	Washer
62	Mechanical Seal	122	Capscrew Hex Hd.
70	Shaft Sleeve	123	Washer
80	Impeller	124	Capscrew Hex Hd.
83	Washer Impeller		

Armstrong Integrated Limited
 Wenlock Way
 Manchester
 United Kingdom, M12 5JL
 T: +44 (0) 8444 145 145
 F: +44 (0) 8444 145 146

S. A. Armstrong Limited
 23 Bertrand Avenue
 Toronto, Ontario
 Canada, M1L 2P3
 T: 416 755 2291
 F: 416 759 9101

