

FILE NO: 42.81  
DATE: Dec. 15, 2002  
SUPERSEDES: 42.81  
DATE: June 15, 2000

SERVICE WORK INSTRUCTIONS

**ARMSTRONG®**

SERIES 4280

MOTOR MOUNTED  
HORIZONTAL END SUCTION PUMP

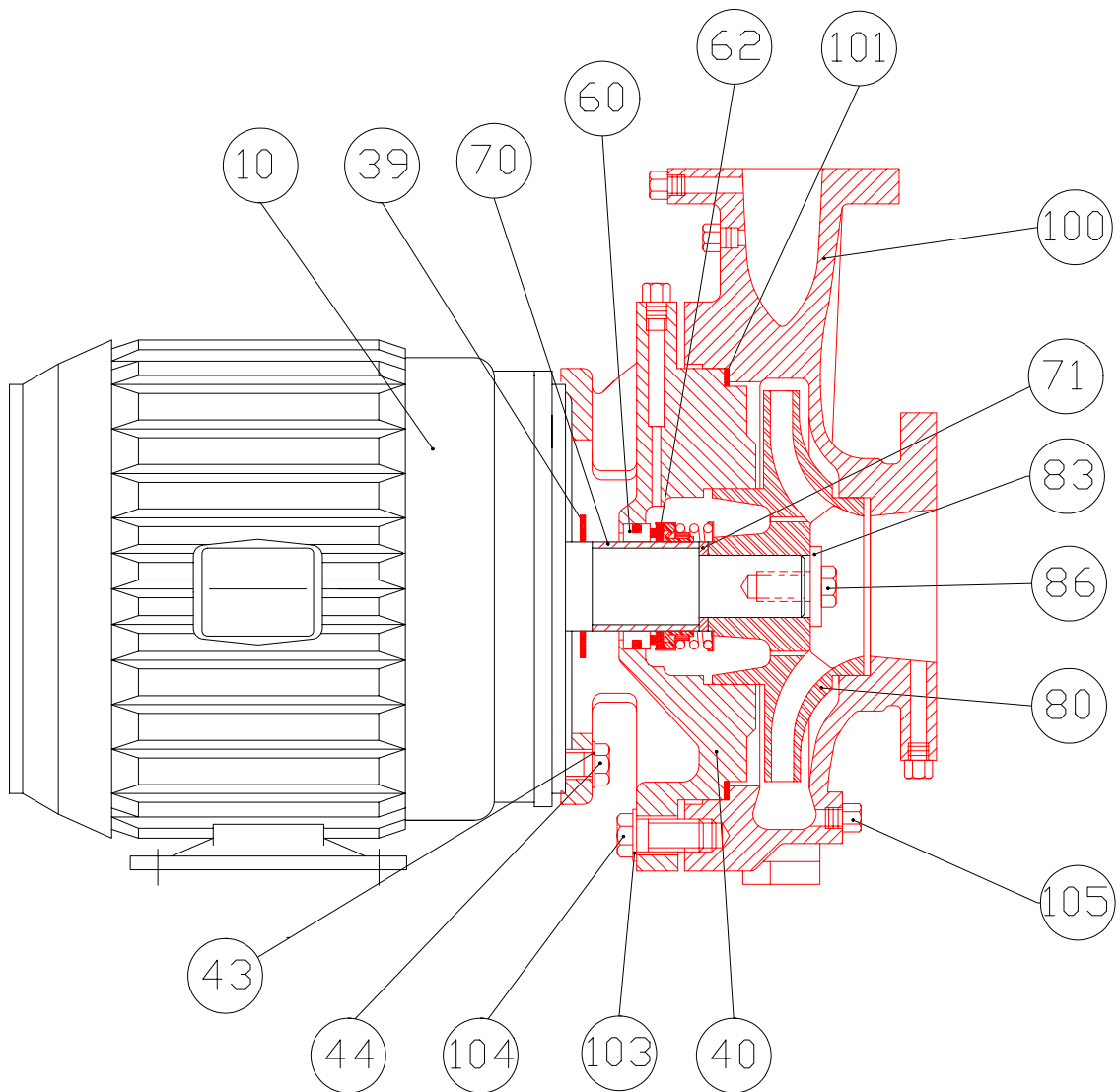

---

# SERVICING ARMSTRONG SERIES 4280 PUMPS

Refer, also, to Armstrong Installation & Operating Instructions for series 4280 motor mounted pumps: **File No: 42.80**  
All component numbers shown in this document refer to the sectional view on front cover

---

The Series 4280 pump is a motor mounted or "close-coupled" type pump, mounted on a ball bearing motor. The pump should be secured to the foundation by means of capscrews inserted, through the motor feet, into flush type anchors embedded in the foundation. This is necessary in order to enable the motor assembly, with pump adapter and impeller to be pulled backwards out of the pump

## BREAKDOWN PROCEDURES:

### 1. ELECTRICAL WIRING

CAUTION
Exercise extreme care when handling power wiring. Ensure that the fuses are removed or breaker disconnected in the power line to the motor. Disconnected power should be within sight of the pump being serviced and tagged with the reason for disconnection.

- If the pump and/or motor assembly is to be serviced on a bench, the motor wiring must be disconnected. This may not be necessary if the pump is to be serviced in place on the foundation.

### 2. ISOLATION VALVES

- If the system is not drained: Ensure that the suction and discharge piping isolation valves are closed. Remove drain plug [105] from the bottom of the casing and drain the pump.

### 3. MOUNTING CAPSCREWS

- The motor mounting capscrews must be removed from the foundation to permit removal of the rotating assembly out of the pump casing [100].

### 4. PREPARE ASSEMBLY FOR REMOVAL

- Remove the casing capscrews and washers [104 & 103]. Pry bars may then be inserted between the casing [100] and adapter [40]. Care should be taken not to apply pressure to the outside diameter of the adapter, to prevent possible breakage. Outside pressure should be on the casing only.

### 5. REMOVE ROTATING ASSEMBLY

- The rotating assembly (Motor, adapter and impeller [10, 40 & 80]) may now be pulled back out of the casing.

Prior to removing the rotating assembly ensure that the casing is supported properly. If flexible connectors are installed in the piping, support the casing in such a manner as to prevent the casing weight from hanging on the flexible connectors.

### 6. ROTATING ASSEMBLY NOTES

- The impeller [80] is fastened directly to the motor shaft and must be removed in order to replace the mechanical seal [60/62]. This may be accomplished while the pump is still on the foundation or more conveniently, on a work bench.

### 7. IMPELLER CAPSCREW

- The impeller [80] should be prevented from rotating while the capscrew [86] is loosened. A heavy screwdriver may be inserted between the impeller blades to enable the impeller capscrew to be backed off with a socket wrench. Remove the impeller capscrew and washer [86 & 83]

### 8. PUMP IMPELLER

- Using wheel pullers, with the jaws behind the rear shroud of the impeller [80] (Behind a vane at each side) pull the impeller free of the pump shaft. Impellers that are difficult to remove may be loosened by heating the impeller hub with a torch during the pulling process. Remove the impeller from the motor shaft. Note the impeller key and shaft sleeve spacer [71]. Remove both for storage.

### 9. REMOVE MECHANICAL SEAL FROM MOTOR SHAFT

- The mechanical seal spring usually comes free with the impeller. The mechanical seal rotating element [62] must be pried loose with pry bars or screwdrivers. Once loosened, the seal may be pulled free of the shaft. Do not damage the carbon face when removing the rotating assembly. It may be needed for analysis if seal failure investigation is required.

### 10. REMOVE SEAL SEAT FROM ADAPTER

- The mechanical seal seat [60], usually "O" ring mounted Ni-Resist material, is pried loose from the recess in the adapter.  
If the seat cannot be removed in this manner, remove the motor capscrews [44] and separate the adapter [40] from the motor [70]. A screwdriver may then be used to push the seat out of the adapter from the rear.

---

## 11. REMOVE OLD CASING GASKET

- The former casing gasket [101] should be scraped from the casing and adapter, leaving clean surfaces for the new gasket. A standard putty knife and wire brush are useful for this purpose)

## ASSEMBLY PROCEDURES:

### 12. REPLACE MECHANICAL SEAL

- Clean the shaft sleeve [70] surface, ensuring all the former seal elastomer pieces have been removed. Inspect for damage. Replace if necessary. (See separate instructions for removal of the shaft sleeve [File No. 6042.25]). Inspect the water slinger [39] and replace if damaged. Install a new seal seat [60] in the adapter cavity, being sure the lapped (polished) side of the insert is facing up. Ensure that the cavity has been thoroughly cleaned. Lubricate the seat "O" ring with a small amount silicon or glycerine lubricant and press down, straight and even, into the cavity. Do not press the seat in with bare fingers, use a clean cloth or the cardboard disc typically supplied with the seal. Contamination of the polished and lapped seat face could cause leakage. If the adapter was removed from the motor, replace now, taking care that the seal seat is carefully guided over the motor shaft.
- Lubricate the inside of the seal rotating assembly [62] with a small amount of silicon or glycerine lubricant and slide onto the shaft sleeve [70] with a twisting motion, carbon face first, until the carbon face is pressed firmly against the seal seat [60]. Pressing on the seal rotating assembly metal parts, with a screw driver, all the way around the seal, will ensure that the faces are mated properly.
- Remove the spring retainer from the seal spring and place the seal spring over the seal rotating assembly.

### 13. REPLACE PUMP IMPELLER

- Install the shaft sleeve spacer [71] and impeller key on the shaft and place the seal spring retainer onto the impeller hub register. Slide the impeller in place on the motor shaft. Take care and ensure that the seal spring is kept in place on the seal rotating assembly and fits well into the retainer on the impeller hub.

### 14. TIGHTEN IMPELLER CAPSCREW

- It is good practice to replace self locking screw, once removed. Install the impeller capscrew and washer [86 & 83]. Hold the impeller the same way as when the capscrew was successfully loosened (Bar or screw driver placed carefully between the impeller blades) and tighten the capscrew with a socket wrench.

### 15. INSTALL NEW CASING GASKET

- Insert new casing gasket [101] onto the register on the adapter.

### 16. SLIDE ROTATING ASSEMBLY INTO PLACE

- The rotating assembly (Motor, adapter and impeller combination [10, 40 & 80]) may now be pushed into place in the casing. Once in place, any casing supports should be removed.

### 17. CASING CAPSCREWS

- The casing capscrews [104] are now installed and evenly tightened with a wrench. Tighten the capscrews a little at a time, **diagonally** across the casing, to assure even gasket pressure.

### 18. MOTOR MOUNTING CAPSCREWS

- The capscrews that hold the pump to the foundation are now installed and tightened.

### 19. ISOLATION VALVES

- Replace the casing drain plug and open the suction and discharge isolation valves.

### 20. MOTOR WIRING

- The motor conduit and its wiring are now replaced. Be sure to check rotation of the motor after rewiring if the motor is three phase and correct if necessary, by switching any two lead wires. Ensure that the pump is filled with water before operating to check rotation.

### 21. CONDUIT BOX COVER

- The conduit box cover is replaced after checking the motor rotation. The pump may now be placed in operation.

---

**Armstrong Pumps Inc.**  
93 East Avenue  
North Tonawanda, New York  
U.S.A. 14120-6594  
Tel: (716) 693-8813  
Fax: (716) 693-8970

**S.A. Armstrong Limited**  
23 Bertrand Avenue  
Toronto, Ontario  
Canada, M1L 2P3  
Tel: (416) 755-2291  
Fax: (416) 759-9101



**Armstrong Pumps Limited**  
Peartree Road, Stanway  
Colchester, Essex  
United Kingdom, CO3 0LP  
Tel: 01206-579491  
Fax: 01206-760532

**Armstrong Darling**  
2200 Place Transcanadienne  
Montreal, Quebec  
Canada, H9P 2X5  
Tel: (514) 421-2424  
Fax: (514) 421-2436

Visit us at [www.armstrongpumps.com](http://www.armstrongpumps.com)

© S.A. Armstrong Limited 2002

