

INSTALLATION AND OPERATING INSTRUCTIONS

**MOTOR MOUNTED CENTRIFUGAL PUMPS
SERIES 4270
MODELS 12, 61, 17**

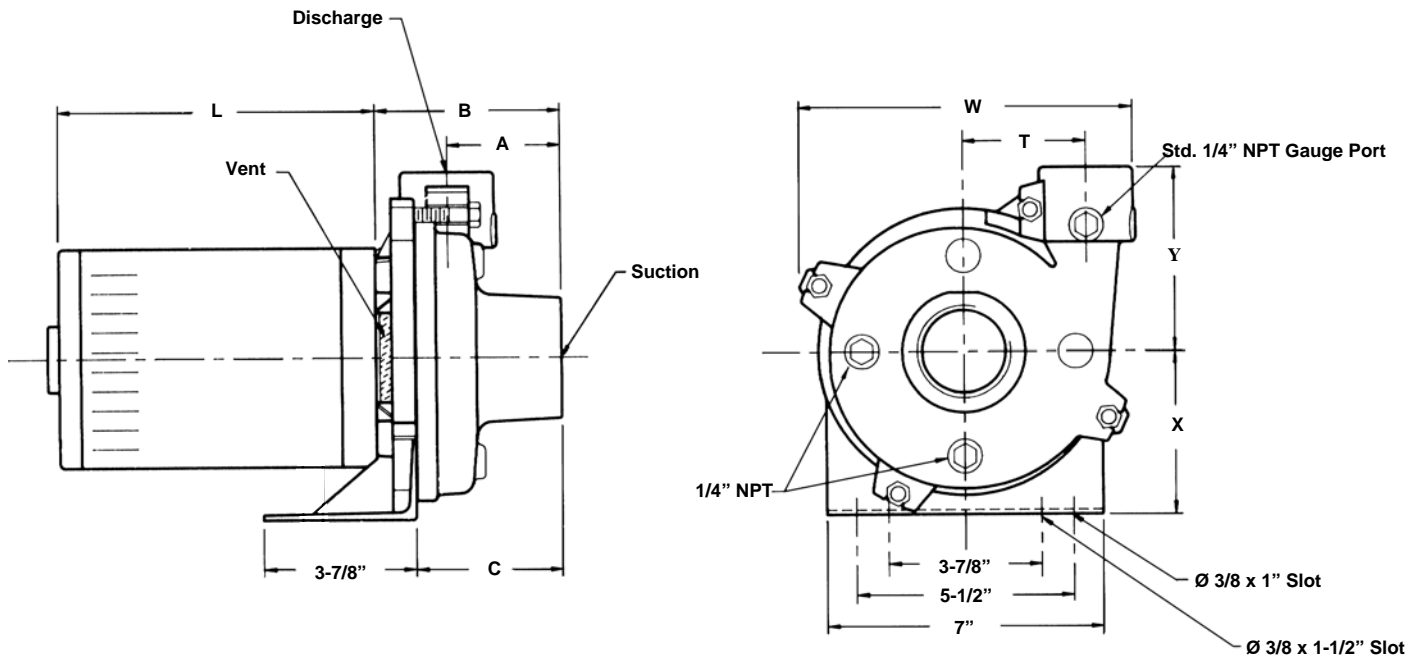

Select Armstrong Installation & Operation (I&O) Guides are now posted in our Wiki site. Visit the Armstrong Wiki site at <http://www.armstrongpumps.com/wiki.html> and share your ideas on best practices for the installation and operation of Armstrong products.

CAUTION

PARTICULAR CARE MUST BE TAKEN TO CHECK THE FOLLOWING BEFORE PUMP IS STARTED UP:

1. Is the pump primed and free of air?
2. Rotation okay?
3. Pipework properly supported?
4. Voltage supply okay?
5. Overload protection okay?
6. Is the system clean?

ARMSTRONG WARRANTY DOES NOT COVER ANY DAMAGE TO THE EQUIPMENT RESULTING FROM FAILURE TO OBSERVE THE ABOVE PRECAUTIONS.

GENERAL:

ARMSTRONG CENTRIFUGAL PUMPS, PROPERLY INSTALLED AND GIVEN REASONABLE CARE AND MAINTENANCE, WILL PERFORM SATISFACTORILY FOR A LONG PERIOD OF TIME. THESE INSTRUCTIONS DESCRIBE THE PROCEDURES WHICH SHOULD BE FOLLOWED TO ENSURE TROUBLE-FREE OPERATION.

LOCATION:

Locate the pump where it is easily accessible for inspection and servicing, and provide adequate headroom for removal of the motor end.

Motor-driven units should not be located in damp atmospheres unless this condition has been provided for in the motor enclosure.

FOUNDATION:

Mount the pump on a foundation sufficiently substantial to absorb any vibration. A good foundation should weigh approximately two-and-one-half times the shipping weight of the pump.

Locate the pump on its foundation and mark off the foundation holes using the motor bracket feet as a template. Use either both outside or both inside slots, whichever is more convenient. Mark the holes to be drilled towards the pump end of the slots for support.

Drill the two holes of the required size and insert the anchors. Take a tamping tool and drive home the lead sleeve anchor until it is below the level of the foundation and firmly fixed to the concrete.

Protruding bolts should be avoided, since this arrangement does not allow disassembly of the unit without disturbing the piping.

LEVELLING:

Before installing the unit, use a straight edge or carpenter's level to check that the mounting surface is level. Place the unit on its foundation and insert shims under the motor bracket feet to take up any irregularities in the concrete. Check the suction and discharge ports for horizontal or vertical position using a straight edge and level. Tighten foundation bolts evenly and recheck level position of pump.

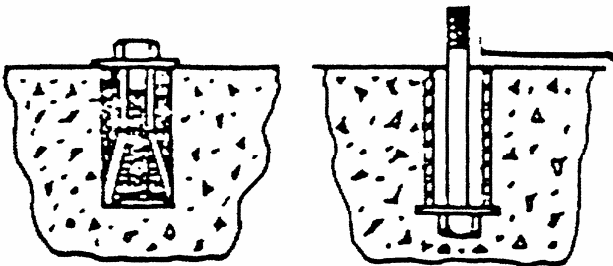

RIGHT

WRONG

PIPING:

Both the suction and discharge pipes should be independently supported near the pump so that no strain is imposed on the pump when the pipes are connected. All connecting pipe work should be accurately located. Do not attempt to force the suction and discharge pipes into position.

Suction Piping: Use short, direct suction one or two times larger than the pump suction nozzle. Arrange piping to eliminate potential air pockets and use an eccentric reducer to connect to the suction nozzle. A strainer three or four times the area of the suction pipe will prevent materials from entering the pump. A gate valve should be installed to permit servicing of the pump.

Discharge Piping: Both ea check and gate valve should be installed in the discharge line. If an increaser is used on the discharge side to increase the size of the discharge pipe, it should be placed between the check valve and the pump.

MOTOR LUBRICATION:

Follow the lubrication procedures recommended by the manufacturer. In most cases it will be found that the motor bearings are custom greased for several years of operation and require little or no attention. Series 4270 Close Coupled Pumps do not require lubrication, as bearings are not used in the motor bracket. The motor should be protected against possible overload conditions. Supplied voltage should be within ten percent of the rated voltage.

MECHANICAL SEAL:

The mechanical seal requires no special attention or adjustment. However, DO NOT RUN PUMP DRY, as the seal must have a thin film of clean liquid between the seal faces for proper operation.

ROTATION:

With the pump fully primed, energize the motor briefly and check that the rotation corresponds with the direction arrow on the pump. To reverse the rotation on a three-phase motor, interchange any two of the leads for single and three-phase motors.

Follow the wiring diagram instructions found on the motor label.

SYSTEM CLEANLINESS:

Before starting the pump, the system must be thoroughly cleaned, flushed, drained, and then replenished with clean liquid. Welding slag and other foreign materials — "Stop Leak" and cleaning compounds — excessive or improper water treatment — are all detriments to the pump internals. Proper operation cannot be guaranteed if any of these conditions are allowed to exist.

STARTING AND STOPPING:

The pump must be fully primed on start-up. Fill the pump casing with water, remove the air release plug in the top of the volute and rotate the shaft by hand to remove any air trapped in the impeller. Start the pump with the discharge gate valve closed, then open gradually after the motor is up to speed. To stop the pump, close the discharge valve and trip the motor starter.

STORAGE:

If the pump is going to sit idle for an extended period of time, the following precautions should be taken to maintain the condition of the pump:

Remove the plugs at the top and bottom of the casing and drain or air blow out all water to prevent rust buildup or if there is a possibility of freezing. Be sure to reinstall plugs when pump is made operational.

Keep the pump and motor stored in a dry location and covered to prevent environmental damage.

Bearings protected by oil or grease should be manually rotated at least once every six months to return oil or grease to the upper half of the bearings.

The suction and discharge openings should be covered to prevent water or foreign objects from entering the casing.

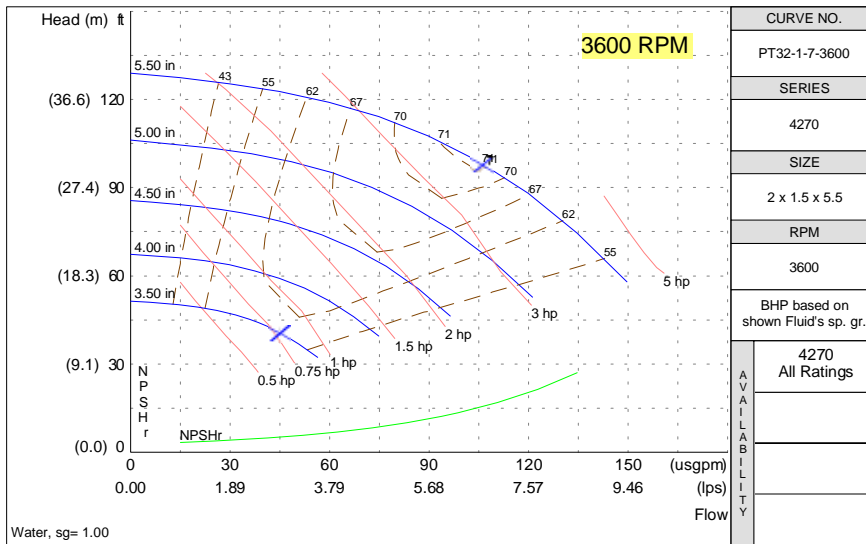
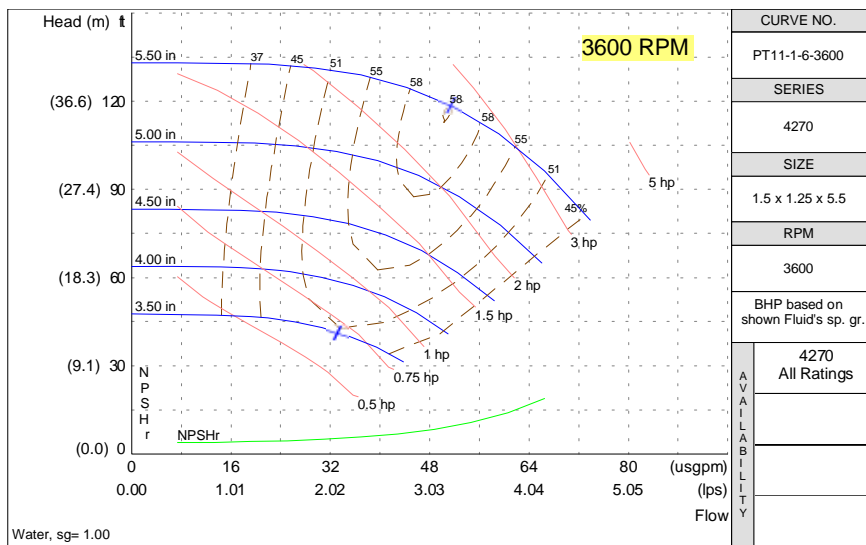
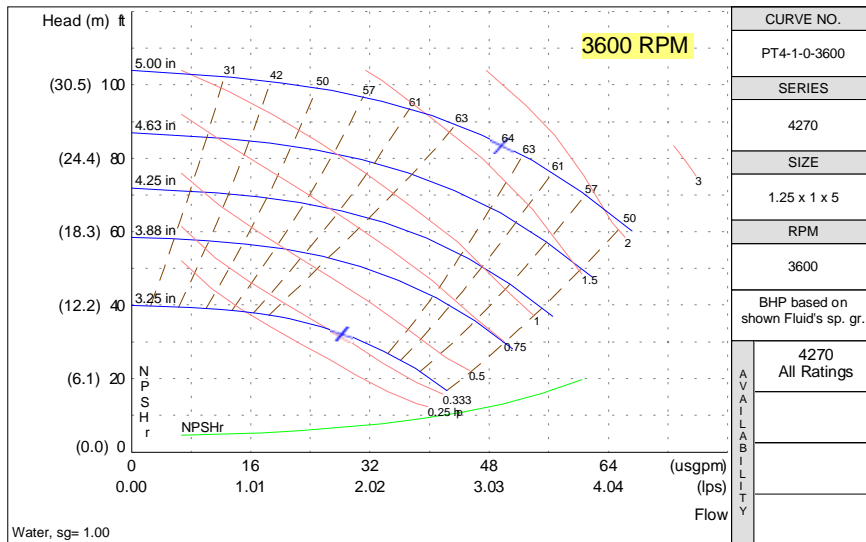

S. A. Armstrong Limited
 23 Bertrand Avenue
 Toronto, Ontario
 Canada, M1L 2P3
 T: (416) 755-2291
 F (Main): (416) 759-9101

Armstrong Pumps Inc.
 93 East Avenue
 North Tonawanda, New York
 U.S.A. 14120-6594
 T: (716) 693-8813
 F: (716) 693-8970

Armstrong Holden Brooke Pullen
 Wenlock Way
 Manchester
 United Kingdom, M12 5JL
 T: +44 (0) 161 223 2223
 F: +44 (0) 161 220 9660



© S.A. Armstrong Limited 1992

For Armstrong locations worldwide, please visit www.armstrongpumps.com